

Jasper County, Iowa Board of Supervisors

PO Box 944, Newton, IA Phone: 641-792-7016 Fax: 641-792-1053

Denny Carpenter

Doug Cupples

Brandon Talsma

September 13, 2022

9:30 a.m.

www.jasperia.org

Live Stream: <https://jasper.zoom.us/j/97712718501>

Meeting ID: 977 1271 8501

Dial In: +1-312-626-6799

- Anyone that has an item on the agenda must appear in person for the Board to consider it. -

Pledge of Allegiance



Item 1 Heartland Greenway System Project – Evan Del Val

Item 2 Human Resources – Dennis Simon

- a) Hiring Resolution for Sheriff's Office Full-Time Jailers – Landon Criswell and Julia Kriegel
- b) Hiring Resolution for Sheriff's Office Part-Time Transport Officer – David Bouck

Item 3 Sheriff – John Halferty

- a) FY2023 Governor's Traffic Safety Bureau Iowa Department of Public Safety (GTSB) Agreement

Item 4 Engineer – Michael Frietsch

- a) Purchase of Temporary Easement for Public Highway on Parcel No. 11.11.100.001
- b) Snow Ordinance for 2022-2023 Winter
- c) Chassis Cab Quote Revision
- d) Living Roadway Trust Fund Grant for Counties Agreement
- e) Purchase of New Hydroseeder

Item 5 Treasurer – Doug Bishop

- a) ARPA Committee Recommendation List
- b) Reassignment of certificates 15-0303 and 15-0304 to the City of Colfax
- c) Abatement of outstanding taxes on parcel CFCF 11.01.336.007 and CFCF 11.01.336.008

Item 6 CICS/Jasper County Business Associate Agreement

Item 7 Approval of Board of Supervisors Minutes for September 6, 2022

PUBLIC INPUT & COMMENTS

September 13, 2022

Mr. Evan Del Val
I+S Group (ISG)
508 E. Locust Street
Des Moines, IA 50309

**RE: LETTER OF INTENT FOR COUNTY REPRESENTATION AND INSPECTION SERVICES FOR THE
HEARTLAND GREENWAY SYSTEM PROJECT
JASPER COUNTY**

Dear Mr. Del Val:

This Letter of Intent gives notice that Jasper County intends to contract with ISG to perform pre-construction activities and all construction inspection services related to the proposed Heartland Greenway System pipeline project (henceforth referred to as "Project"). It is our understanding that all costs associated with these services will be paid for by the Project owners, and that Jasper County will act as a pass-through agent. This Letter of Intent is predicated on the Iowa Utilities Board (IUB) approving the permit application for the Project and is neither a show of support nor opposition of the Project. If the IUB denies the permit, this Letter of Intent will be considered null and void.

Sincerely,

Chairman of the Board of Supervisors

County Engineer

County Auditor

Resolution 22-

WHEREAS, a position vacancy has been approved for the following appointment by the Board of Supervisors through the Personnel Requisition Process.

NOW, THEREFORE BE IT RESOLVED that the Board of Supervisors approves and certifies the following appointment to the Auditor for payroll implementation:

<u>DEPARTMENT</u>	<u>POSITION</u>	<u>EMPLOYEE</u>	<u>PAY RATE</u>	<u>RANGE/STEP</u>	<u>EFFECTIVE DATE</u>
Sheriff Office	Part-Time Transport Officer	David Bouck	\$17.30	Range 29 Step 5 Non-Bargaining Hourly Scale	9/14/2022

Resolution adopted this 13th day of September 2022

Brandon Talsma, Chairman

Attest:

Dennis Parrott, Auditor

**GOVERNOR'S TRAFFIC SAFETY BUREAU
IOWA DEPARTMENT OF PUBLIC SAFETY**

CONTRACT NUMBER: State and Community Highway Safety Grant
PAP 23-402-M0PT, Task 42-00-00
Impaired Driving Countermeasures Grant
PAP 23-405d-M6OT, Task 00-42-00

PROJECT TITLE: Jasper Co SO-HVE OT

ISSUING AGENCY: DPS/Governor's Traffic Safety Bureau

PROJECT CONTRACTOR: Jasper County Sheriff's Office

PROJECT BUDGET: Highway Safety Funded Amount: \$9,450.00

AGENCY/LAW/SOURCE: National Highway Traffic Safety Administration (NHTSA)
Public Law 117-58, Section 402 and Section 405d

Submit Reimbursement Claims To:

Sheri Krohn, Program Administrator
Governor's Traffic Safety Bureau
215 East 7th Street, 3rd Floor
Des Moines, Iowa 50319-0248

Issue Payment To:

Jasper County Sheriffs
2300 Law Center Drive
Newton, Iowa 50208

Submit Reports To:

Sheri Krohn, Program Administrator
Governor's Traffic Safety Bureau
215 East 7th Street, 3rd Floor
Des Moines, Iowa 50319-0248
515-725-6128, FAX 515-725-6133

Transmit Contract Information To:

Lieutenant Michael Gunsaulus
Jasper County Sheriff's Office
2300 Law Center Drive
Newton, Iowa 50208
641-792-5912, FAX 641-792-4202

The Contractor agrees to furnish and deliver all products and perform all services set forth in the attached Special Conditions for the consideration stated herein. The rights and obligations of the parties to this contract will be subject to and governed by the Special Conditions and the General Conditions. To the extent that any specifications or other conditions which are made a part of this contract by reference or otherwise conflict, the Special Conditions and the General Conditions will control. To the extent that any inconsistency between the Special Conditions and the General Conditions exists, the Special Conditions will control. When approved, the instrument becomes a contract to accomplish the provisions contained within the Fiscal Year 2023 Highway Safety Plan, State and Community Highway Safety Grant 23-402-M0PT, Task 42-00-00 and Impaired Driving Countermeasures Grant 23-405d-M6OT, Task 00-42-00, and thereby constitutes an official program with the Governor's Traffic Safety Bureau. This activity meets the requirements of Public Law 117-58 and the requirements set forth in the Governor's Traffic Safety Bureau Procedures Manual, as amended.

IN WITNESS THEREOF, the parties hereto have executed this contract on the day and year last specified below.

CONTRACTOR: _____ Date: _____ Attest: _____
By _____ Date: _____

ISSUING AGENCY:  _____
By _____ Date: 09/22/2022
Brett A. Tjepkes, Bureau Chief

Effective Date: 10/01/22 Expiration Date: 09/30/23

GENERAL FEDERAL AWARD INFORMATION PER § 200.210

- | | |
|-------------------------------------|------------------------------------------------------------------------------------------------------|
| 1) Recipient: | Jasper County Sheriff's Office |
| 2) UEI: | PYELZUMFUSR3 |
| 3) FAIN: | 69A37521300004020IA0
69A3752030000405DIAL |
| 4) Federal Award Date | 1/19/2021 (402), 2/3/2020 (405d) |
| 5) Period of Performance: | 10/1/22-9/30/23 |
| 6) Federal Funds: | 9,450.00 |
| 7) Total Funds Obligated: | 9,450.00 |
| 8) Total Amount of Federal Award: | 9,450.00 |
| 9) Approved Budget: | Refer to the signed agreement/award |
| 10) Recipient Match Requirement: | None |
| 11) Description: | High Visibility Enforcement OT (Gen/ID) |
| 12) Federal Awarding Agency: | National Highway Traffic Safety Administration |
| 13) CFDA: | 20.600 - State & Community Highway Safety Grants
20.616 - Impaired Driving Countermeasures Grants |
| 14) Research and Development Funds: | No |
| 15) Indirect Cost Rate: | Not applicable |

SPECIAL CONDITIONS

Article 1.0 Identification of Parties. This Contract is entered into by and between the Iowa Department of Public Safety/Governor's Traffic Safety Bureau (hereafter referred to as DPS/GTSB) and the Jasper County Sheriff's Office (hereinafter referred to as Contractor).

Article 2.0. Statement of Purpose.

WHEREAS, the Highway Safety Plan is the tool for developing and improving overall safety capabilities; improving the program management and decision-making capabilities of safety officials; addressing special problems or opportunities; and providing a coordination mechanism for the purpose of reducing traffic-related property damage, personal injury and fatal crashes, and

WHEREAS, the DPS/GTSB has been designated to administer the State and Community Highway Safety Programs established under Section 402 and Section 405d of the Infrastructure Investment and Jobs Act, as amended, and

WHEREAS, the Contractor has the necessary ability to develop and carry out a portion of that Highway Safety Plan,

THEREFORE, the parties hereto do agree as follows:

Article 3.0 Area Covered. The Contractor will perform all the work and services required under this Contract in connection with and respecting the following areas:

County of Jasper, Iowa and other jurisdiction(s) authorized by a shared enforcement agreement.

Article 4.0 Reports and Products. The Contractor will submit the following reports and products:

- 4.1 A Claim for Reimbursement form, documentation and, if applicable, an Equipment Accountability Report form for reimbursement within 90 days of the expense being paid by the Contractor with the exception of the final claim which is due into the DPS/GTSB office no later than November 15, 2023.

- 4.2 A cumulative final report due November 1, 2023 covering accomplishments of Statement of Work and Services.
- 4.3 Any reports and products deemed prudent by the Issuing Agency or Contractor.
- 4.4 A copy of all audit reports within 30 days of completion of said audit.
- 4.5 Monthly activity reports due the 15th of the following month on forms provided by the DPS/GTSB that quantify project activities.

Article 5.0 Designation of Officials.

- 5.1 DPS/GTSB - The Governor's Representative for Highway Safety and the Director of the Governor's Traffic Safety Bureau are the only persons authorized to execute and approve any changes in terms, conditions, or amounts specified in this Contract.
- 5.2 Contractor Designee, Sheriff John Halferty, is designated to approve in writing, on behalf of the Contractor, the Claim for Reimbursement and any negotiated changes in this Contract.

Article 6.0 Key Personnel. The Contractor hereby assigns the duties and responsibilities of project administration to Lieutenant Michael Gunsaulus, representing the Contractor in this agreement.

Article 7.0 Time of Performance. The services of the Contractor will commence on or after the effective date stipulated on the signature page and will be completed before or by the expiration date.

Article 8.0 Modification of General Conditions. None.

Article 9.0 Additional Special Conditions.

- 9.1 Expense Documentation. The Contractor will document the expenditure of such funds authorized as eligible for reimbursement in accordance with the conditions of this Contract upon submission of the Claim and, for equipment, the Equipment Accountability Report as supplied by the DPS/GTSB.
- 9.2 Policies and Procedures. The Contractor will comply with all policies and procedures contained in the Iowa DPS/GTSB Policies and Procedures Manual, as amended, including appropriate attachments provided by the DPS/GTSB in accordance with Section 402 and Section 405d of the Infrastructure Investment and Jobs Act, and the Iowa Administrative Code, Section 661, Chapter 20.
- 9.3 Copyrights. The Federal awarding agency reserves a royalty-free, nonexclusive, and irrevocable license to reproduce, publish or otherwise use, and to authorize others to use, for Federal Government purposes:
 - a. The copyright in any work developed under a grant, sub-grant, or contract under a grant or sub-grant; and
 - b. Any rights of copyright to which a grantee, sub grantee or a contractor purchases ownership with grant support.
- 9.4 Debarred, Suspended and Ineligible Status. The Contractor certifies that the Contractor and/or any of its subcontractors have not been debarred, suspended or declared ineligible by any agency of the State of Iowa or as defined in the Federal Acquisition Regulation (FAR) 48 C.F.R. Ch.1 Subpart 9.4. The Contractor will immediately notify the DPS/GTSB if the Contractor is debarred by the State or

placed on the Consolidated List of Debarred, Suspended and Ineligible Contractors by a federal entity.

a. *Instructions for Primary Tier Participant Certification*

- 1) By signing and submitting this proposal, the prospective primary tier participant is providing the certification set out below and agrees to comply with the requirements of 2 CFR parts 180 and 1200.
- 2) The inability of a person to provide the certification required below will not necessarily result in denial of participation in this covered transaction. The prospective primary tier participant shall submit an explanation of why it cannot provide the certification set out below. The certification or explanation will be considered in connection with the department or agency's determination whether to enter into this transaction. However, failure of the prospective primary tier participant to furnish a certification or an explanation shall disqualify such person from participation in this transaction.
- 3) The certification in this clause is a material representation of fact upon which reliance was placed when the department or agency determined to enter into this transaction. If it is later determined that the prospective primary tier participant knowingly rendered an erroneous certification, in addition to other remedies available to the Federal Government, the department or agency may terminate this transaction for cause or default or may pursue suspension or debarment.
- 4) The prospective primary tier participant shall provide immediate written notice to the department or agency to which this proposal is submitted if at any time the prospective primary tier participant learns its certification was erroneous when submitted or has become erroneous by reason of changed circumstances.
- 5) The terms *covered transaction, civil judgment, debarment, suspension, ineligible, participant, person, principal, and voluntarily excluded*, as used in this clause, are defined in 2 CFR parts 180 and 1200. You may contact the department or agency to which this proposal is being submitted for assistance in obtaining a copy of those regulations.
- 6) The prospective primary tier participant agrees by submitting this proposal that, should the proposed covered transaction be entered into, it shall not knowingly enter into any lower tier covered transaction with a person who is proposed for debarment under 48 CFR part 9, subpart 9.4, debarred, suspended, declared ineligible, or voluntarily excluded from participation in this covered transaction, unless authorized by the department or agency entering into this transaction.
- 7) The prospective primary tier participant further agrees by submitting this proposal that it will include the clause titled "Instructions for Lower Tier Participant Certification" including the "Certification Regarding Debarment, Suspension, Ineligibility and Voluntary Exclusion—Lower Tier Covered Transaction," provided by the department or agency entering into this covered transaction, without modification, in all lower tier covered transactions and in all solicitations for lower tier covered transactions and will require lower tier participants to comply with 2 CFR parts 180 and 1200.
- 8) A participant in a covered transaction may rely upon a certification of a prospective participant in a lower tier covered transaction that it is not proposed for debarment under 48 CFR part 9, subpart 9.4, debarred, suspended, ineligible, or voluntarily excluded from the covered transaction, unless it knows that the certification is erroneous. A participant is responsible for ensuring that its principals are not suspended, debarred, or otherwise ineligible to participate in covered transactions. To verify the eligibility of its principals, as well as the eligibility of any prospective lower tier participants, each participant may, but is not required to, check the

System for Award Management Exclusions website (<https://www.sam.gov/>).

- 9) Nothing contained in the foregoing shall be construed to require establishment of a system of records in order to render in good faith the certification required by this clause. The knowledge and information of a participant is not required to exceed that which is normally possessed by a prudent person in the ordinary course of business dealings.
- 10) Except for transactions authorized under paragraph 6 of these instructions, if a participant in a covered transaction knowingly enters into a lower tier covered transaction with a person who is proposed for debarment under 48 CFR part 9, subpart 9.4, suspended, debarred, ineligible, or voluntarily excluded from participation in this transaction, in addition to other remedies available to the Federal government, the department or agency may terminate the transaction for cause or default.

b. *Debarment, Suspension, and Other Responsibility Matters-Primary Tier Covered Transactions*

- 1) The prospective primary tier participant certifies to the best of its knowledge and belief, that it and its principals:
 - i. Are not presently debarred, suspended, proposed for debarment, declared ineligible, or voluntarily excluded from participating in covered transactions by any Federal department or agency;
 - ii. Have not within a three-year period preceding this proposal been convicted of or had a civil judgment rendered against them for commission of fraud or a criminal offense in connection with obtaining, attempting to obtain, or performing a public (Federal, State or local) transaction or contract under a public transaction; violation of Federal or State antitrust statutes or commission of embezzlement, theft, forgery, bribery, falsification or destruction of records, making false statements, or receiving stolen property;
 - iii. Are not presently indicted for or otherwise criminally or civilly charged by a governmental entity (Federal, State or Local) with commission of any of the offenses enumerated in paragraph (1)(b) of this certification; and
 - iv. Have not within a three-year period preceding this application/proposal had one or more public transactions (Federal, State, or local) terminated for cause or default.
- 2) Where the prospective primary tier participant is unable to certify to any of the Statements in this certification, such prospective participant shall attach an explanation to this proposal.

c. *Instructions for Lower Tier Participant Certification*

- 1) By signing and submitting this proposal, the prospective lower tier participant is providing the certification set out below and agrees to comply with the requirements of 2 CFR parts 180 and 1200.
- 2) The certification in this clause is a material representation of fact upon which reliance was placed when this transaction was entered into. If it is later determined that the prospective lower tier participant knowingly rendered an erroneous certification, in addition to other remedies available to the Federal government, the department or agency with which this transaction originated may pursue available remedies, including suspension or debarment.
- 3) The prospective lower tier participant shall provide immediate written notice to the person to which this proposal is submitted if at any time the prospective lower tier participant learns that its certification was erroneous when submitted or has become erroneous by reason of changed circumstances.

- 4) The terms *covered transaction, civil judgment, debarment, suspension, ineligible, participant, person, principal, and voluntarily excluded*, as used in this clause, are defined in 2 CFR parts 180 and 1200. You may contact the person to whom this proposal is submitted for assistance in obtaining a copy of those regulations.
- 5) The prospective lower tier participant agrees by submitting this proposal that, should the proposed covered transaction be entered into, it shall not knowingly enter into any lower tier covered transaction with a person who is proposed for debarment under 48 CFR part 9, subpart 9.4, debarred, suspended, declared ineligible, or voluntarily excluded from participation in this covered transaction, unless authorized by the department or agency with which this transaction originated.
- 6) The prospective lower tier participant further agrees by submitting this proposal that it will include the clause titled "Instructions for Lower Tier Participant Certification" including the "Certification Regarding Debarment, Suspension, Ineligibility and Voluntary Exclusion – Lower Tier Covered Transaction," without modification, in all lower tier covered transactions and in all solicitations for lower tier covered transactions and will require lower tier participants to comply with 2 CFR parts 180 and 1200.
- 7) A participant in a covered transaction may rely upon a certification of a prospective participant in a lower tier covered transaction that it is not proposed for debarment under 48 CFR part 9, subpart 9.4, debarred, suspended, ineligible, or voluntarily excluded from the covered transaction, unless it knows that the certification is erroneous. A participant is responsible for ensuring that its principals are not suspended, debarred, or otherwise ineligible to participate in covered transactions. To verify the eligibility of its principals, as well as the eligibility of any prospective lower tier participants, each participant may, but is not required to, check the System for Award Management Exclusions website (<https://www.sam.gov>).
- 8) Nothing contained in the foregoing shall be construed to require establishment of a system of records in order to render in good faith the certification required by this clause. The knowledge and information of a participant is not required to exceed that which is normally possessed by a prudent person in the ordinary course of business dealings.
- 9) Except for transactions authorized under paragraph 5 of these instructions, if a participant in a covered transaction knowingly enters into a lower tier covered transaction with a person who is proposed for debarment under 48 CFR part 9, subpart 9.4, suspended, debarred, ineligible, or voluntarily excluded from participation in this transaction, in addition to other remedies available to the Federal government, the department or agency with which this transaction originated may pursue available remedies, including suspension or debarment.

d. *Debarment, Suspension, Ineligibility and Voluntary Exclusion Lower Tier Covered Transactions*

- 1) The prospective lower tier participant certifies, by submission of this proposal, that neither it nor its principals is presently debarred, suspended, proposed for debarment, declared ineligible, or voluntarily excluded from participating in covered transactions by any Federal department or agency.
- 2) Where the prospective lower tier participant is unable to certify to any of the statements in this certification, such prospective participant shall attach an explanation to this proposal.

9.5 Equipment acquired under this agreement for use in highway safety program areas shall be used and kept in operation for highway safety purposes 23 CFR 1300.31.

- a. *Title.* Except as provided in paragraphs (e) and (f) of this section, title to equipment acquired under 23 U.S.C. Chapter 4 and Section 1906 will vest upon acquisition in the State or its subrecipient, as appropriate, subject to the conditions in paragraphs (b) through (d) of this section.
- b. *Use.* All equipment shall be used for the originally authorized grant purposes for as long as needed for those purposes, as determined by the Regional Administrator, and neither the State nor any of its subrecipients or contractors shall encumber the title or interest while such need exists.
- c. *Management and disposition.* Subject to the requirements of paragraphs (b), (d), (e), and (f) of this section, States and their subrecipients and contractors shall manage and dispose of equipment acquired under 23 U.S.C. Chapter 4 and Section 1906 in accordance with State laws and procedures.
- d. *Purchases and dispositions.* Contractors shall receive prior written approval for all in-car camera purchases and any equipment purchases over \$4,000 from GTSB by submitting a quote from the vendor for the equipment to verify the acquisition price. GTSB will determine if further approval is required from NHTSA based on the acquisition price on the quote. Claims for equipment submitted by the Contractor must match the quote exactly which was approved by GTSB. GTSB considers equipment purchased using federal funds to have a useful life expectancy of at least a 5 years minimum unless documentation is provided to the contrary.
 - 1) Equipment with a useful life of more than one year and an acquisition cost of \$5,000 or more shall be subject to the following requirements:
 - i. Purchases shall receive prior written approval from GTSB and NHTSA. Failure to secure prior approval will result in the contractor being responsible for the cost of the equipment purchase; retroactive approval from NHTSA is not an option.
 - ii. Dispositions shall receive prior written approval from NHTSA unless the equipment has exceeded its useful life as determined by GTSB policy.
 - 2) Equipment with a useful life of more than one year and an acquisition cost of less than \$5,000 shall be subject to the following requirements:
 - i. Dispositions shall be reported to GTSB.
 - ii. Equipment destroyed during its useful life shall be replaced by the department. The department will notify GTSB of the date the equipment was rendered unusable and the replacement information to include: manufacturer, date equipment was received, serial number and a photo with serial number.
- e. *Right to transfer title.* The Regional Administrator may reserve the right to transfer title to equipment acquired under this part to the Federal Government or to a third party when such third party is eligible under Federal statute. Any such transfer shall be subject to the following requirements:
 - 1) The equipment shall be identified in the grant or otherwise made known to the State in writing;
 - 2) The Regional Administrator shall issue disposition instructions within 120 calendar days after the equipment is determined to be no longer needed for highway safety purposes, in the absence of which the State shall follow the applicable procedures in 2 CFR parts 200 and 1201.
- f. *Federally-owned equipment.* In the event a State or its subrecipient is provided federally-owned equipment:
 - 1) Title shall remain vested in the Federal Government;
 - 2) Management shall be in accordance with Federal rules and procedures, and an annual inventory listing shall be submitted by the State;

- 3) The State or its subrecipient shall request disposition instructions from the Regional Administrator when the item is no longer needed for highway safety purposes.
- 4) DPS/GTSB does not allow equipment purchased using federal funds to be sold without written prior approval from GTSB.

9.6 Nondiscrimination. The Contractor will comply with all Federal statutes and implementing regulations relating to nondiscrimination ("Federal Nondiscrimination Authorities"). These include but are not limited to:

- Title VI of the Civil Rights Act of 1964 (42 U.S.C. 2000d et seq., 78 stat. 252), (prohibits discrimination on the basis of race, color, national origin) and 49 CFR part 21;
- The Uniform Relocation Assistance and Real Property Acquisition Policies Act of 1970, (42 U.S.C. 4601), (prohibits unfair treatment of persons displaced or whose property has been acquired because of Federal or Federal-aid programs and projects);
- Federal-Aid Highway Act of 1973, (23 U.S.C. 324 et seq.), and Title IX of the Education Amendments of 1972, as amended (20 U.S.C. 1681-1683 and 1685-1686) (prohibit discrimination on the basis of sex);
- Section 504 of the Rehabilitation Act of 1973, (29 U.S.C. 794 et seq.), as amended, (prohibits discrimination on the basis of disability) and 49 CFR part 27;
- The Age Discrimination Act of 1975, as amended, (42 U.S.C. 6101 et seq.), (prohibits discrimination on the basis of age);
- The Civil Rights Restoration Act of 1987, (Pub. L. 100-209), (broadens scope, coverage and applicability of Title VI of the Civil Rights Act of 1964, The Age Discrimination Act of 1975 and Section 504 of the Rehabilitation Act of 1973, by expanding the definition of the terms "programs or activities" to include all of the programs or activities of the Federal aid recipients, subrecipients and contractors, whether such programs or activities are Federally-funded or not);
- Titles II and III of the Americans with Disabilities Act (42 U.S.C. 12131-12189) (prohibits discrimination on the basis of disability in the operation of public entities, public and private transportation systems, places of public accommodation, and certain testing) and 49 CFR parts 37 and 38;
- Executive Order 12898, Federal Actions to Address Environmental Justice in Minority Populations and Low-Income Populations (prevents discrimination against minority populations by discouraging programs, policies, and activities with disproportionately high and adverse human health or environmental effects on minority and low-income populations); and
- Executive Order 13166, Improving Access to Services for Persons with Limited English Proficiency (guards against Title VI national origin discrimination/discrimination because of limited English proficiency (LEP) by ensuring that funding recipients take reasonable steps to ensure that LEP persons have meaningful access to programs (70 FR 74087-74100).

The Contractor:

- a. Will take all measures necessary to ensure that no person in the United States shall, on the grounds of race, color, national origin, disability, sex, age, limited English proficiency, or membership in any other class protected by Federal Nondiscrimination Authorities, be excluded from participation in, be denied the benefits of, or be otherwise subjected to discrimination under any of its programs or activities, so long as any portion of the program is Federally-assisted;
- b. Will administer the program in a manner that reasonably ensures that any of its subrecipients, contractors, subcontractors, and consultants receiving Federal financial assistance under this program will comply with all

requirements of the Non- Discrimination Authorities identified in this Assurance;

- c. Agrees to comply (and require its subrecipients, contractors, subcontractors, and consultants to comply) with all applicable provisions of law or regulation governing US DOT's or NHTSA's access to records, accounts, documents, information, facilities, and staff, and to cooperate and comply with any program or compliance reviews, and/or complaint investigations conducted by US DOT or NHTSA under any Federal Nondiscrimination Authority;
- d. Acknowledges that the United States has a right to seek judicial enforcement with regard to any matter arising under these Non-Discrimination Authorities and this Assurance;
- e. Agrees to insert in all contracts and funding agreements with other State or private entities the following clause:

"During the performance of this contract/funding agreement, the contractor/funding recipient agrees:

- a. To comply with all Federal nondiscrimination laws and regulations, as may be amended from time to time;
- b. Not to participate directly or indirectly in the discrimination prohibited by any Federal non-discrimination law or regulation, as set forth in appendix B of 49 CFR part 21 and herein;
- c. To permit access to its books, records, accounts, other sources of information, and its facilities as required by the State highway safety office, US DOT or NHTSA;
- d. That, in event a contractor/funding recipient fails to comply with any nondiscrimination provisions in this contract/funding agreement, the State highway safety agency will have the right to impose such contract/agreement sanctions as it or NHTSA determine are appropriate, including but not limited to withholding payments to the contractor/funding recipient under the contract/agreement until the contractor/funding recipient complies; and/or cancelling, terminating, or suspending a contract or funding agreement, in whole or in part; and
- e. To insert this clause, including paragraphs (a) through (e), in every subcontract and subagreement and in every solicitation for a subcontract or sub-agreement, that receives Federal funds under this program

9.7 Buy America Act. The Contractor will comply with the Buy America requirement (23 U.S.C. 313) when purchasing items using Federal funds. Buy America requires Contractors to purchase with Federal funds only steel, iron and manufactured products produced in the United States, unless the Secretary of Transportation determines that such domestically produced items would be inconsistent with the public interest, that such materials are not reasonably available and of a satisfactory quality, or that inclusion of domestic materials will increase the cost of the overall project contract by more than 25 percent. In order to use Federal funds to purchase foreign produced items, the State must submit a waiver request that provides an adequate basis and justification for approval by the Secretary of Transportation.

9.8 Political Activity (Hatch Act). The Contractor will comply, as applicable, with provisions of the Hatch Act (5 U.S.C. §§1501-1508 and 7324-7328) which limit the political activities of employees whose principal employment activities are funded in whole or in part with Federal funds. As such, the Contractor will not subcontract with any agency to conduct DPS/GTSB contract-related activities.

9.9 State Lobbying Restrictions. None of the funds under this program will be used for any activity specifically designed to urge or influence a State or local legislator to favor or oppose the adoption of any specific legislative proposal pending before any State or local legislative body. Such activities include both direct and indirect (e.g., "grassroots") lobbying activities, with one exception. This does not preclude a State official whose salary is supported with NHTSA funds from engaging in direct communications with State or local legislative officials, in accordance with customary State practice, even if such communications urge legislative officials to favor or oppose the adoption of a specific pending legislative proposal.

9.10 Federal Lobbying Restrictions. The undersigned certifies, to the best of his or her knowledge and belief, that:

- a. No Federal appropriated funds have been paid or will be paid, by or on behalf of the undersigned, to any person for influencing or attempting to influence an officer or employee of any agency, a Member of Congress, an officer or employee of Congress, or an employee of a Member of Congress in connection with the awarding of any Federal contract, the making of any Federal grant, the making of any Federal loan, the entering into of any cooperative agreement, and the extension, continuation, renewal, amendment, or modification of any Federal contract, grant, loan, or cooperative agreement;
- b. If any funds other than Federal appropriated funds have been paid or will be paid to any person for influencing or attempting to influence an officer or employee of any agency, a Member of Congress, an officer or employee of Congress, or an employee of a Member of Congress in connection with this Federal contract, grant, loan, or cooperative agreement, the undersigned shall complete and submit Standard Form-LLL, "Disclosure Form to Report Lobbying," in accordance with its instructions;
- c. The undersigned shall require that the language of this certification be included in the award documents for all sub-award at all tiers (including subcontracts, subgrants, and contracts under grant, loans, and cooperative agreements) and that all subrecipients shall certify and disclose accordingly.

This certification is a material representation of fact upon which reliance was placed when this transaction was made or entered into. Submission of this certification is a prerequisite for making or entering into this transaction imposed by section 1352, title 31, U.S. Code. Any person who fails to file the required certification shall be subject to a civil penalty of not less than \$10,000 and not more than \$100,000 for each such failure.

9.11 Prohibition on Using Grant Funds to Check for Helmet Usage. The Contractor will not use 23 U.S.C. Chapter 4 grant funds for programs to check helmet usage or to create checkpoints that specifically target motorcyclists.

9.12 Contract Amendments. Contract amendments must occur if there is a change in budget within the same funding source, to change the required scope of work, a change in an equipment purchase including quantity or addressing an unplanned occurrence. A letter must be submitted by the Contract Designee to GTSB for approval. Once GTSB has issued an approval for the change, the Contractor may proceed with the amended activity. No change in a contractual agreement will be accepted within 60 days of the close of the contract.

Article 10.0 Conditions of Payment.

10.1 Maximum Payments. It is expressly understood and agreed the maximum amount to be paid to the Contractor by the DPS/GTSB for any item of work or service will

be the amount specified under Article 12.0 subject to Article 11.0 herein. It is further understood and agreed the total of all payments to the Contractor by the DPS/GTSB for all work and services required under this Contract will not exceed \$9,450.00 unless modified by written amendment of this Contract as provided in Section 1.0 of the General Conditions.

- 10.2 Claim for Reimbursement. All payments to the Contractor will be subject to the DPS/GTSB's receipt of a Claim and documentation. A Claim will be submitted on a form provided by the DPS/GTSB. Expenses will need to be paid prior to submitting the claim for reimbursement. If claiming equipment, an Equipment Accountability Report must also be submitted. The Contractor must perform services (as defined in sections 11.7 and 11.8 of this contract) between the effective dates of the contract to qualify for reimbursement. The Contractor shall receive goods no later than July 31 as stated in section 11.9 of this contract to qualify for reimbursement, unless prior approval is granted. No payments will be made if required reports are more than two months past due unless approved by the DPS/GTSB Director. GTSB reserves the right to deny payment when there has not been performance of any activities defined in the Statement of Work and Services.
- 10.3 Receipt of Federal Funds.
- a. All payments hereunder will be subject to the receipt of federal funds by the DPS/GTSB. The termination, reduction, or delay of federal funds to the DPS/GTSB may be reflected by a corresponding modification to the conditions of this Contract.
 - b. Notwithstanding any other provisions of this Contract, if funds anticipated for the continued fulfillment of this Contract are at any time not forthcoming or insufficient, either through failure of the State of Iowa to appropriate funds, discontinuance or material alteration of the program for which funds were provided, the DPS/GTSB will have the right to terminate this Contract without penalty by giving not less than thirty (30) days written notice documenting the lack of funding, discontinuance or program alteration. Unless otherwise agreed to by the parties, the Contract will become null and void on the last day of the fiscal year for which appropriations were received, except that if an appropriation to cover cost of this Contract becomes available within sixty (60) days subsequent to termination under this clause, the DPS/GTSB agrees to re-enter a Contract with the terminated Contractor under the same provisions, terms and conditions as the original Contract.
 - c. In the event of termination of this Contract due to non-appropriation, the exclusive, sole and complete remedy of Contractor will be payment for services rendered prior to termination.
- 10.4 Non-Performance Termination. If, through any cause, the Contractor shall fail to fulfill in a timely and proper manner its obligation under this contract, or if the Contractor shall violate any of the agreements or stipulations of this contract, the DPS/GTSB shall thereupon have the right to terminate this contract and withhold further payment of any kind by giving written notice to the Contractor of such termination and specifying the effective date thereof, at least thirty (30) days before such date. The DPS/GTSB shall be the sole arbitrator of whether the Contractor or its subcontractor is performing its work in a proper manner with reference to the quality of work performed by the Contractor or its subcontractor under the provisions of this contract. The Contractor and the DPS/GTSB further agree that this contract may be terminated by either party by giving written notice of such termination and specifying the effective date thereof, at least thirty (30) days before such date.

- 10.5 The Contractor will arrange for a single audit to be performed in accordance with 2 CFR 200 when, as a non-federal entity, the Contractor receives \$750,000.00 or more in federal funds. The federal agency, National Highway Traffic Safety Administration, Department of Transportation, passes funds through the Department of Public Safety, Governor's Traffic Safety Bureau. The Catalog of Federal Domestic Assistance (CFDA) number 20.600 applies to State & Community Highway Safety Grants and 20.616 applies to Impaired Driving Countermeasures Grants. A copy of the audit report will be submitted to the DPS/GTSB within thirty (30) days after the completion of the audit.

Article 11.0 Statement of Work and Services. The Contractor will perform in a satisfactory and proper manner, as determined by the DPS/GTSB the following work and services:

- 11.1 The Contract will be monitored by the National Highway Traffic Safety Administration (NHTSA) and the DPS/GTSB. All records and documents pertaining to the project are subject to auditing and evaluation by those agencies or their designees.
- 11.2 The Contractor will absorb all costs not contained in this contract.
- 11.3 The project will be evaluated on all items contained in the Statement of Work and Services and the Budget.
- 11.4 There will be no change in the Statement of Work and Services or Budget without prior written approval of the DPS/GTSB.
- 11.5 The Contractor will comply with all requirements contained within the Policies and Procedures Manual of the DPS/GTSB.
- 11.6 All documents relative to fiscal claims will be maintained in the Contractor's office and will be available for review during regular office hours.
- 11.7 Staffing plan:
 - a. Deputies to conduct 53 hours of directed overtime for general enforcement with documented enforcement action(s) issued to violator(s).
 - b. Deputies to conduct 74 hours of directed overtime for impaired enforcement with documented enforcement action(s) issued to violator(s).
- 11.8 Contract activities:
 - a. Conduct 53 overtime hours of planned general (402-funded) high visibility traffic enforcement with an effort directed at occupant restraint, impaired driving and excessive speed violations during times and at locations identified as high-risk.
 - b. Conduct 74 overtime hours of planned impaired driving (405d-funded) high visibility enforcement directed at impaired driving during times and at locations that have been identified by your agency, the Iowa DOT or the DPS/GTSB to have a high occurrence for impaired driving.
 - c. Conduct at least two targeted traffic enforcement projects, one of which will be conducted at night and one a multi-jurisdictional project.
 - d. Conduct at least twelve public information/education activities aimed at improving driver safety behaviors.
 - e. Conduct two observational occupant protection surveys; one in May and one in September. Each survey is to be conducted for one hour or one hundred

observed cars, whichever comes first. Observational surveys should be conducted at a location that has an average or above average volume of traffic on a daily basis. Subsequent observational surveys should be conducted at the same location, day of week and time of day as previously recorded.

- f. Purchase two NHTSA-approved moving radars and utilize for speed enforcement.
- g. Purchase one DPS-approved preliminary breath tester (PBT) and utilize for impaired driving-related traffic enforcement.

11.9 Key dates:

- a. By November 15, 2022 and the 15th of each subsequent month through October 15, 2023, submit a monthly report as specified in Article 4.5.
- b. By July 31, 2023, receive two moving radars and one PBT as specified in Article 11.8(f) and (g).
- c. By August 10, 2023, submit claim for expenses incurred through June 30, 2023.
- d. By November 1, 2023, submit an annual report as specified in Article 4.2.
- e. By November 15, 2023, submit final claim for reimbursement.

11.10 Reporting requirements/performance measures:

- a. At least 53 hours of general overtime enforcement conducted and all overtime traffic enforcement contacts reported showing a sustained effort based on past performance.
- b. At least 74 hours of impaired overtime enforcement conducted and all overtime traffic enforcement contacts reported showing a sustained effort based on past performance.
- c. Two targeted traffic enforcement projects completed and results reported.
- d. Twelve public information activities conducted, documented and reported.
- e. Two occupant protection surveys completed and reported.
- f. Two moving radars and one PBT purchased and utilized.

Article 12.0 Project Budget.

Highway Safety
Funds

Personnel Services

Directed overtime for general enforcement (402) \$ 2,500.00

Directed overtime for impaired enforcement (405d) \$ 3,500.00

Equipment

Two moving radars (402) \$ 3,000.00

One PBT (405d) \$ 450.00

TOTAL \$ 9,450.00

WHAT'S NEW FOR FFY 2023!!

DOCUMENTED OVERTIME ENFORCEMENT

Written Warnings and Citations Required

Contract language contained in section 11.7 of the contract as it relates to enforcement contacts has been revised from previous years to clarify documentation of enforcement actions. All enforcement contact activity generated while conducting GTSB overtime enforcement will be written citations and written warnings issued to violators. Issuing violators enforcement action in the form of citations and warnings is the most effective method to deter risky driving behavior.

NEW PLATFORM FOR IOWA GRANTS

Coming in December

The State of Iowa is changing Iowa Grants over to a new and improved platform. This change over is planned for December 9th. In order to migrate information from the old system to the new system, Iowa Grants will be shut down and unavailable starting December 4th. The change will also require users to reregister with a new single sign on system (OKTA). Instructions for registering and the new platform will be provided prior to the go live date. Please watch for more information as this transition happens.

OBSERVATIONAL OCCUPANT PROTECTION SURVEYS

Changed to May and September

To better align with the Click It Or Ticket National Enforcement Mobilization, GTSB is requesting the first of two required observational occupant protection surveys be completed in May. The second survey should be completed in September to capture the effectiveness of the enforcement mobilization efforts. Guidelines for conducting the surveys are in section 11.8 of the contract. Key tips and a tally sheet can be found in Iowa Grants in the Program Documents.

REMINDERS

EQUIPMENT PURCHASES

As outlined in your contract in section 9.5(d), each agency is required to **submit a quote for any equipment that will have a purchase price of more than \$4,000**. This includes, but is not limited to, in-car video cameras and their components, speed trailers and TruCam lidars. If the quote is for more than \$5,000, GTSB will obtain the necessary approval from NHTSA. The quote must to be approved by the Program Administrator (PA) before the equipment can be purchased. Only the approved items on the quote should be included on the invoice that is submitted with the claim for reimbursement. If other items are purchased to go along with the equipment, they will need to be invoiced separately by the vendor. This change is needed to ensure that proper approvals for equipment over \$5,000 are obtained **prior to purchase** in accordance to 23 CFR 1300.31. **Reminder:** Equipment must be received by the agency by July 31.

IOWA GRANTS INSTRUCTIONS

Written step-by-step instructions can be found in Iowa Grants under Program Documents. Written and video instructions can also be found on the GTSB website.

<https://dps.iowa.gov/divisions/commissioners-office/governors-traffic-safety/gtsb-forms>

PERSONAL INFORMATION

When submitting paystubs or pay verification, please redact or mark out any personal information listed on the documentation. This includes addresses, social security numbers or employee numbers.

JASPER COUNTY ENGINEER'S OFFICE

910 N 11th Ave E
Newton, Iowa 50208

(641) 792-5862
FAX – (641) 791-7740



Michael J. Frietsch, P.E, FMP
County Engineer
mfrietsch@jasperia.org

August 22, 2022

To: Cecil Moffitt Farms, LLC
PO Box 965
Newton IA 50208

Re: Bridge Project Temporary Construction Easement

Dear Mr. Moffitt:

The bridge on Highway F-48 West over Squaw Creek west of W 116th St S is programmed for replacement. The construction limits will temporarily extend beyond the existing right-of-way line. Hence the need to purchase temporary easement. The following are provided with this letter:

1. Temporary Construction Easement Location Map
2. Temporary Construction Easement Plat – Parcel 2
3. Temporary Construction Easement for Public Highway
4. Compensation Estimate

Please sign the Temporary Construction Easement document as indicated before a notary. Please return the executed documents in the enclosed envelope. Feel free to contact me at 641-521-6018 or email me at mfrietsch@jasperia.org with any questions or concerns.

Sincerely,

A handwritten signature in black ink, appearing to read "Michael J. Frietsch", is written above the typed name.

Michael J. Frietsch, P.E., FMP
County Engineer

Attachments

Prepared by and Return to: Jasper County Highway Department, 910 N 11th Ave E, Newton, IA 50208
Temporary Construction Easement for Public Highway
Parcel No. 1111100001

For the consideration of Thirty One and 50/100 -----(31.50)-----DOLLARS and other valuable consideration in hand paid by Jasper County, Iowa, Cecil Moffitt Farms LLC, of Jasper County, State of Iowa, do hereby grant to Jasper County, Iowa a temporary construction easement for road purposes and for use as a Public Highway in, to, on, over and across real estate in Jasper County, Iowa.

THE EASEMENT RIGHT GRANTED FOR HIGHWAY PURPOSES IS TO LAND DESCRIBED AS FOLLOWS:

Temporary Construction Easement:

TEMPORARY CONSTRUCTION EASEMENT PARCEL NO. 2

That part of the Northwest Quarter of the Northwest Quarter of Section 11, Township 79 North, Range 21 West of the Fifth Principal Meridian, Jasper County, Iowa, described as follows:

Commencing at the Northwest Corner of said Section 11;
thence on an assumed bearing South 89 degrees 55 minutes 44 seconds East 329.66 feet along the north line of said Northwest Quarter of the Northwest Quarter;
thence South 00 degrees 00 minutes 00 seconds East 76.74 feet to the present right of way line of a Jasper County Highway to the point of beginning;
thence South 22 degrees 47 minutes 45 seconds West 239.02 feet along said present right of way line; thence North 67 degrees 21 minutes 37 seconds West 30.00 feet;
thence North 22 degrees 38 minutes 23 seconds East 165.83 feet;
thence South 82 degrees 05 minutes 15 seconds West 38.47 feet;
thence North 08 degrees 02 minutes 22 seconds West 42.63 feet to said present right of way line;
thence North 79 degrees 23 minutes 07 seconds East 102.28 feet along said present right of way line to the point of beginning;

Said tract contains 0.21 acres.

This easement and transfer is exempt for transfer tax. Iowa Code Sec. 428A.2(17).

This easement is being acquired for public purposes and a Declaration of Value is not required. Iowa Code Sec. 428A.1.

Grantors do hereby covenant with grantees, and successors in interest, that grantors hold the real estate by title in fee simple, that they have good and lawful authority to sell and convey the real estate; that the real estate is free and clear of all liens and encumbrances except as may be above stated; and grantors covenant to warrant and defend the real estate against the lawful claims of all persons except as may be above stated. Each of the undersigned hereby relinquishes all rights of dower, homestead and distributive share in and to the easement.

Words and phrases herein, including acknowledgement hereof, shall be construed as in the singular or plural number, and as masculine or feminine gender, according to the context.

Dated August 31, 2022 (SIGN IN INK)

Juli A. Johnson TTEE Cecil Moffitt Farms LLC

STATE OF Iowa, COUNTY OF Jasper, ss:

On this 31st day of August, 2022 before me, the undersigned, a Notary Public in and for said state, personally appeared Juli Johnson to me known to be the identical person named in and who executed the foregoing instrument and acknowledged that they executed the same as their voluntary act and deed.

Brandi Hodge (Sign in Ink)

Brandi Hodge (Print/Type Name)
Notary Public in and for the State

Jasper County Project Number: BRS-C050(116)—60-50

Board of Supervisor Chairperson Date
Brandon Talsma



Attest: Dennis K Parrott - Auditor Date: _____

COMPENSATION ESTIMATE

Parcel ID Number: 1111100001
Project Number: BRS-C050(116)--60-50
County: Jasper
Owner(s) of Record: Cecil Moffitt Farms LLC

Owner's Mailing Address: PO Box 965
Newton, IA 50208

Basis for land value estimate: Jasper County Resolution 09-09-34

Land to be aquired:	Fee Title	0.00 acres @	= \$	-
	Permanent Easement	0.00 acres @	= \$	-
	Temporary Construction Easement	0.21 acres @ \$ 150.00	= \$	31.50
	Fence	0.00 rods @	= \$	-

Other considerations:

TOTAL ESTIMATE: **\$ 31.50**

Certification: I hereby certify that I am familiar with the property which is subject of this estimate, that the estimate is based on data contained in the file of the agency, that I have no direct or indirect present or future personal interest in this property or in any benefit from the aquisition of this property.

Signed:

Michael J. Frietsch, P.E., FMP
Jasper County Engineer

Date of Estimate:

8/22/2022

INDEX LEGEND

COUNTY: JASPER
SECTION: 11, T-79N, R-21W, NW 1/4 OF THE NW 1/4

SURVEY FOR: Jasper County Engineer, Newton, IA
OWNERS: Cecil Moffitt Farms, LLC, Newton, IA

SURVEYOR & SURVEY COMPANY:
Jason S. Lowry, P.L.S.
Lowry Land Services, L.L.C.
752 Diamond Trail Rd., Searsboro, Iowa 50242

PREPARED BY AND RETURN TO:
Jason S. Lowry, P.L.S.
752 Diamond Trail Rd., Searsboro, Iowa 50242
(541) 521-1160, lowrylandservices@gmail.com

TEMPORARY CONSTRUCTION EASEMENT - PARCEL 2
NW 1/4 of the NW 1/4, SEC. 11, T-79N, R-21W,
JASPER COUNTY, IOWA

(SEE PAGE 2 FOR GRAPHICAL REPRESENTATION OF THIS PLAT OF SURVEY)

DESCRIPTION OF TEMPORARY CONSTRUCTION EASEMENT PARCEL - 2

That part of the Northwest Quarter of the Northwest Quarter of Section 11, Township 79 North, Range 21 West of the Fifth Principal Meridian, Jasper County, Iowa, described as follows:

Commencing at the Northwest Corner of said Section 11;
thence on an assumed bearing South 89 degrees 55 minutes 44 seconds East 329.66 feet along the north line of said Northwest Quarter of the Northwest Quarter;
thence South 00 degrees 00 minutes 00 seconds East 76.74 feet to the present right of way line of a Jasper County Highway to the point of beginning;
thence South 22 degrees 47 minutes 45 seconds West 239.02 feet along said present right of way line;
thence North 67 degrees 21 minutes 37 seconds West 30.00 feet;
thence North 22 degrees 38 minutes 23 seconds East 165.83 feet;
thence South 82 degrees 05 minutes 15 seconds West 38.47 feet;
thence North 08 degrees 02 minutes 22 seconds West 42.63 feet to said present right of way line;
thence North 79 degrees 25 minutes 07 seconds East 102.28 feet along said present right of way line to the point of beginning;

Said tract contains 0.21 acres.

MEASURED DISTANCE/BEARING - (M)
RECORDED DISTANCE/BEARING - (R)

MONUMENTS

- ▲ - found sec. cor. (pipe, stone, etc.)
- set - 5/8" x 18" rebar with pink plastic cap P.L.S. 22291
- - no monument found or set
- - found lot cor.



I hereby certify that this land surveying document was prepared and the related survey work was performed by me or under my direct personal supervision and that I am a duly Licensed Land Surveyor under the laws of the State of Iowa.

My license renewal date is 12/31/2023

Pages covered by this seal: 1 - 2

PRELIMINARY EASEMENT FOR REVIEW

Jason S. Lowry Iowa Lic. No. 22291 Date

LOWRY LAND SERVICES, L.L.C. 752 DIAMOND TRAIL RD., SEARSBORO, IOWA 50242, 541-521-1160

PROJ. NO. BRS--SWAP--C050(116)--FF-50

PAGE 1

TEMPORARY CONSTRUCTION EASEMENT - PARCEL 2
 NW 1/4 of the NW 1/4, SEC. 11, T-79N, R-21W,
 JASPER COUNTY, IOWA



SEC. COR. TO SEC. COR. = S 89° 55' 44" E - 2851.51

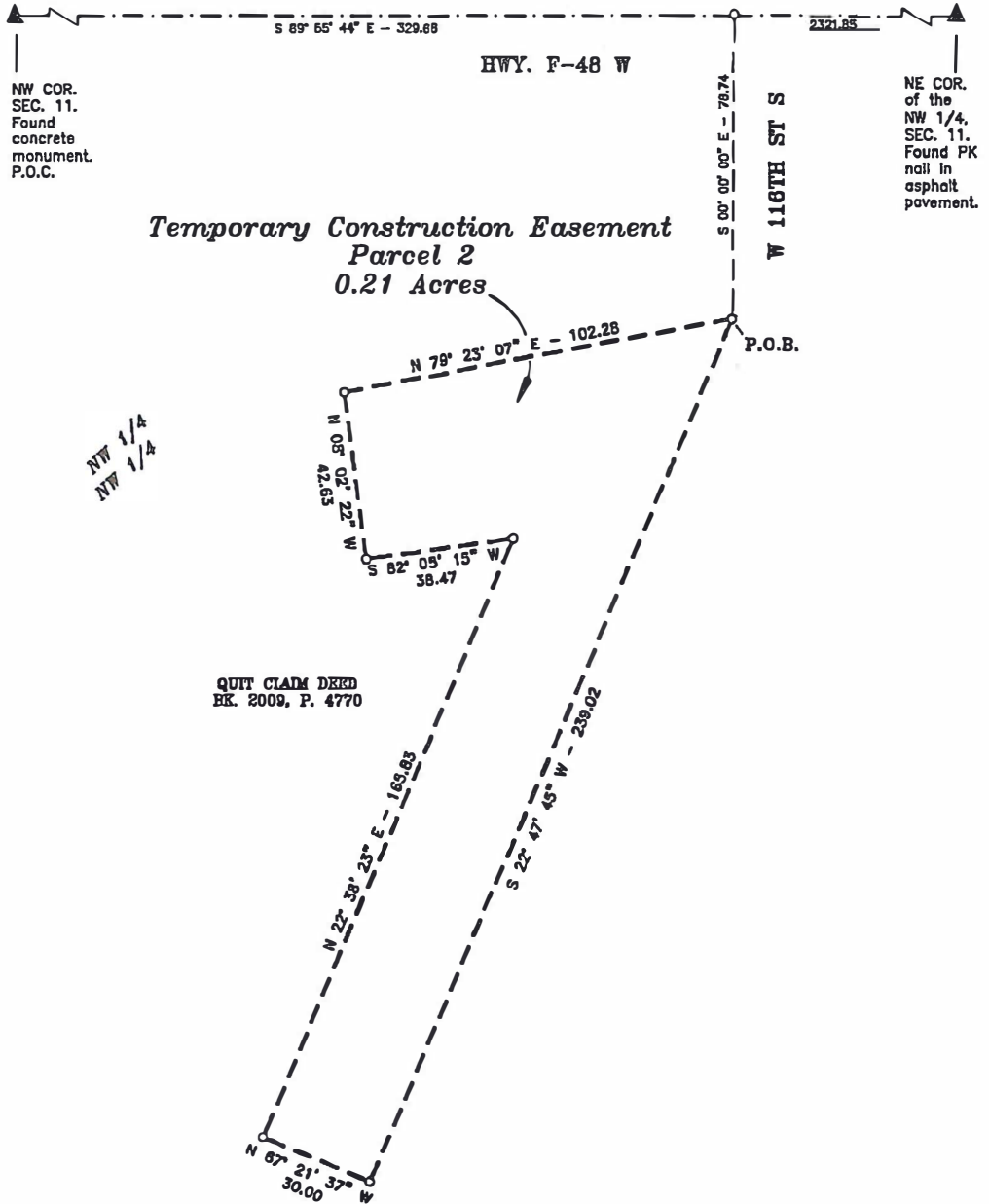

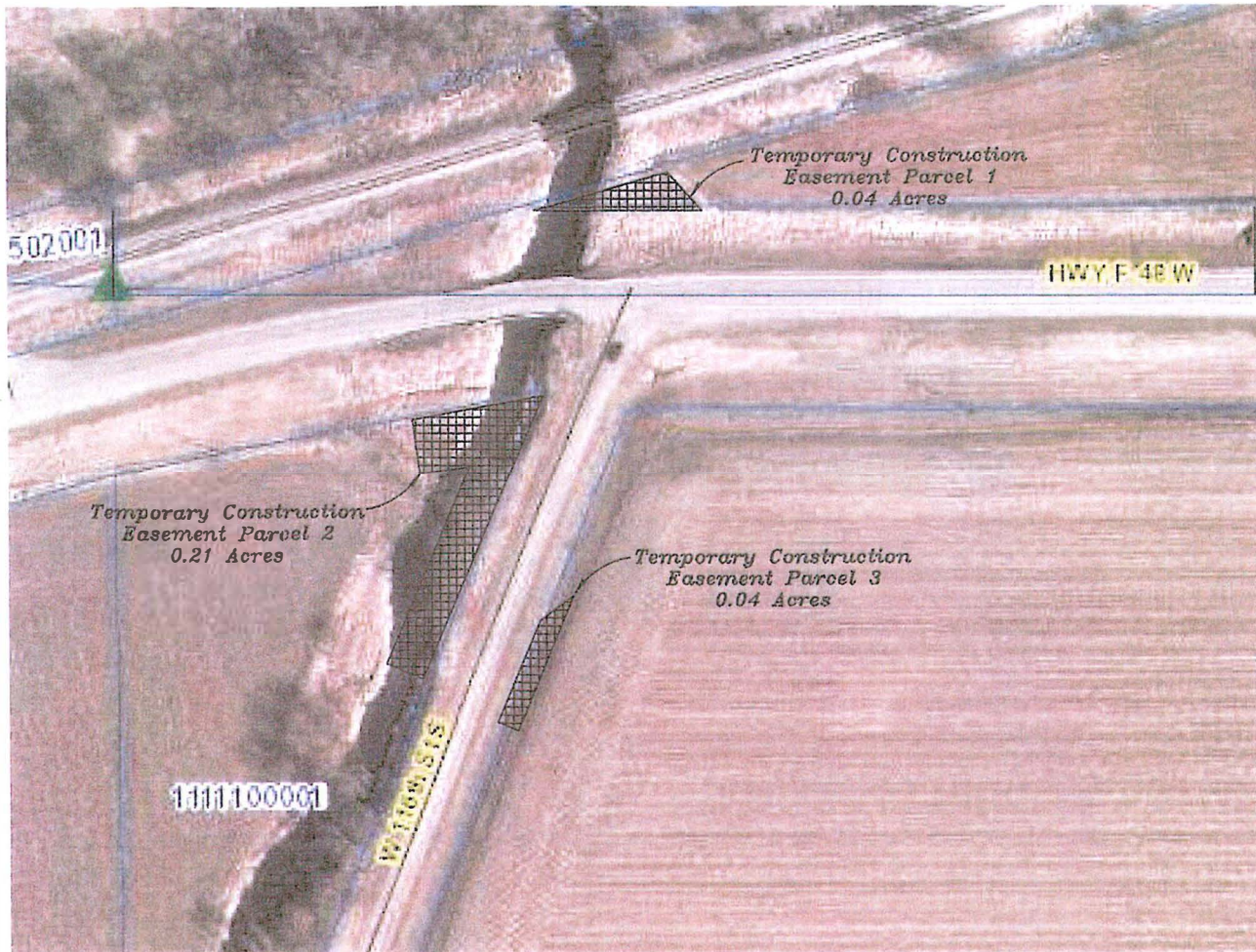

Temporary Construction
Easement Parcel 1
0.04 Acres

HWY F 48 W

Temporary Construction
Easement Parcel 2
0.21 Acres

Temporary Construction
Easement Parcel 3
0.04 Acres

WILLOW STS

502001

1111100001

THE POLICY AND LEVEL OF SERVICE IN RESPECT TO CLEARANCE OF SNOW OR ICE AND THE MAINTENANCE OF JASPER COUNTY'S SECONDARY ROADS DURING THE WINTER MONTHS.

BE IT ORDAINED ON THIS 13TH DAY OF SEPTEMBER 2022 BY THE BOARD OF SUPERVISORS OF JASPER COUNTY, IOWA:

SECTION 1 – PURPOSE

The purpose of this ordinance is to establish Jasper County's policy and level of service in respect to clearance of snow or ice and the maintenance of its secondary road system during the winter months, pursuant to the provisions of Section 668.10 and 309.67, Code of Iowa. This policy and level of service are to be implemented within the amount of money budgeted for this service, and as contained in Jasper County's secondary road budget, as adopted by the Jasper County Board of Supervisors, and as submitted to and approved by the Iowa Department of Transportation.

SECTION 2 – LEVEL OF SERVICE

Clearance of snow or ice and the maintenance of the secondary road system during the winter months is primarily for the benefit of the local residents of Jasper County. Each storm has individual characteristics and must be dealt with accordingly. The portion of the road surface improved for travel may have upon it snow or ice in a compacted condition. These conditions may be continuous, or they may be more concentrated on hills or curves, in valleys, and/or at intersections. Jasper County's existing snow removal equipment will be utilized for the correction of these problems. All clearance of snow or ice, sanding, salting, and other maintenance, in respect to winter conditions, shall be accomplished within the amount of money budgeted for this service. The entire surfaced width of that portion of road improved for travel may not be cleared of snow, ice, compacted snow and ice, or frost. Snow cleared from that part of the roadway surface improved for travel shall be placed on the adjacent shoulders, or in the adjacent ditches or right of way. Snow can be expected to accumulate adjacent to this travelled portion to the extent that a motorist's sight distance to both the left and right may be greatly reduced or impaired. The snow removed from intersections will be piled in the intersection corners in piles of unequal heights. The line of sight, sight distance, or visibility of motorists approaching these intersections may be greatly reduced or impaired. Jasper County shall not be responsible for snow pushed or otherwise placed on the roadway or shoulders by others. Motorists shall drive their vehicles, during these conditions, with additional caution and watchfulness, especially in respect to the surface of the roadway, and the reduced or impaired visibility. In respect to roadways that have only one lane open, further extreme watchfulness and caution must be exercised by the motorists. During these conditions, no additional warning or regulatory signs will be placed to warn of impaired sight distances, reduced visibility at intersections, road blockages, one lane conditions, or that the road surface is slick or slippery, or what the advised speed should be.

SECTION 3 – SEQUENCE OF SERVICE

In the implantation of snow and ice removal and other maintenance of Jasper County's secondary road system during the winter months, the County Engineer shall select the actual sequence of roads to be cleared, as provided for in this Section of this Policy, and shall determine when drifting snow, wind velocity, and additional snow or snowstorms require that the snow removal equipment be removed from the roadway, or that additional clearance of paved routes be accomplished prior to the clearance of granular surfaced roads. The County Engineer's or their designee's professional judgment shall prevail unless it is clearly erroneous.

PAVED ROUTES:

1. Truck-mounted snowplows and spreaders operation is between the hours of 4:30 A.M. and 5:30 P.M. Operations may be suspended if snow and blowing reduces visibility to hazardous working conditions, in the professional judgment of the County Engineer or his delegated representative.
2. Initial effort will be to open routes to one lane traffic in accordance with Item 1 above.
3. Subsequent snow removal will resume during normal working hours.
4. Motor graders may be used in conjunction with the truck-mounted snowplows to open, or keep open, the paved routes, delaying the opening of granular surfaced roads.
5. County may place salt, sand, or other abrasives (treatment) on intersections, hills, and curves once they are plowed. Retreatment may not occur between snowstorms. Treatment operations shall be limited to the hours set forth in Item 1 above.
6. Jasper County is not obligated to provide a "dry" pavement condition.

UNPAVED ROADS:

1. Motor grader snow removal operation is between the hours of 4:30 A.M. and 5:30 P.M.
2. Operations may be suspended if snow and blowing reduces visibility to hazardous working conditions, in the professional judgment of the County Engineer or his delegated representative.
3. Motor grader snow removal operations will **NOT** be undertaken on holidays, Saturdays, or Sundays, when the expected snowfall total is 3 inches or less, unless drifting snow and blockages of roads occurs.
4. Initial effort will be to provide at least one path of ingress and egress for each inhabited residence. The roads or portions or roads involved may vary for each event.
5. After providing inhabited residences with at least one ingress and egress pathway, these same routes will be widened to two lane travel in preparation for the next event.
6. Upon completion of Items 3 and 4 above, the remaining unopened routes (those without occupied residences) will be opened to one lane travel, then, as time and resources allow, to two lane travel.
7. Snow will not be removed from roads designated as Level "B" roads.

PRIVATE DRIVES:

Jasper County will not clear snow from private drives, except for emergencies as defined in Section 5. Normal snow removal operations will result in snow being deposited in private driveways. This deposited snow shall be the responsibility of the resident to remove from the driveway. Snow from private drives shall not be placed on the roadway or shoulders. The resident shall be responsible for the removal of any snow left on the roadway surface or road shoulders due to the clearing of his driveway.

MAILBOXES AND MAILBOX PULLOUTS:

The County shall not replace, or repair mailboxes destroyed or damaged during snow removal operations unless it can be shown that the plow blade actually struck the mailbox. The County will not replace mailboxes damaged or knocked down from the force of snow thrown from the plow.

TIME LIMIT:

There is no time limit after a snowstorm in which any of the above sequence of clearance, on paved or unpaved roads, shall take place.

SECTION 4 – LIMITATION OF SERVICE

The policy and level of service provided for in this policy shall not include, and the following services shall not be performed:

1. Sanding, salting, or placing of other abrasives upon the roadways or bridges that are slick, slippery, and dangerous due to the formation of frost.
2. Sanding, salting, or placing other abrasives upon paved roadways due to freezing rain that occurs between 5:30 P.M. and 4:30 A.M.
3. Placing of additional warning or regulatory signs warning of impaired sight distances, visibility at intersections, road blockages, one lane conditions, or that the road surface is slick or slippery, or what the advised speed should be.

SECTION 5-EMERGENCY

This sequence of service may be suspended during "Emergency" conditions. An "Emergency" condition shall be considered as one where a loss of life is probable, where a serious injury has occurred, or where extensive loss of property is imminent. These conditions should be verified through a physician's or sheriff's office. Jasper County will respond to all "Emergency" conditions, either during or after a snowstorm.

The provisions of this policy shall be further suspended in the event the Governor, by proclamation, implements the State disaster plan, or the Chairman of the Jasper County Board of Supervisors, by proclamation, implements the Jasper County disaster plan. If such occurs, Jasper County personnel and equipment shall be immediately subject to the direction of the Governor or the Chairman of the Jasper County Board of Supervisors.

SECTION 6-SEVERABILITY CLAUSE

Should any section, clause, sentence, or provision of this policy be declared, by the courts, invalid for any reason, such declaration shall not affect the validity of this policy as a whole or any part thereof, other than the section, clause, sentence, or provision so declared to be invalid.

12/08/2020

THE POLICY AND LEVEL OF SERVICE IN RESPECT TO CLEARANCE OF SNOW OR ICE AND THE MAINTENANCE OF JASPER COUNTY'S SECONDARY ROADS DURING THE WINTER MONTHS.

BE IT ORDAINED:

BY THE BOARD OF SUPERVISORS OF JASPER COUNTY, IOWA:

SECTION 1—PURPOSE

The purpose of this ordinance is to establish Jasper County's policy and level of service in respect to clearance of snow or ice and the maintenance of its secondary road system during the winter months, pursuant to the provisions of Section 668.10 and 309.67, Code of Iowa. This policy and level of service are to be implemented within the amount of money budgeted for this service, and as contained in Jasper County's secondary road budget, as adopted by the Jasper County Board of Supervisors and as submitted to and approved by the Iowa Department of Transportation.

SECTION 2—LEVEL OF SERVICE

Clearance of snow or ice and the maintenance of the secondary road system during the winter months is primarily for the benefit of the local residents of Jasper County. Each storm has individual characteristics and must be dealt with accordingly. The portion of the road surface improved for travel may have upon it snow or ice in a compacted condition. These conditions may be continuous, or they may be more concentrated on hills or curves, in valleys, and/or at intersections. Jasper County's existing snow removal equipment will be utilized for the correction of these problems. All clearance of snow or ice, sanding, salting, and other maintenance, in respect to winter conditions, shall be accomplished within the amount of money budgeted for this service. The entire surfaced width of that portion of road improved for travel may not be cleared of snow, ice, compacted snow and ice, or frost. Snow cleared from that part of the roadway surface improved for travel shall be placed on the adjacent shoulders, or in the adjacent ditches or right of way. Snow can be expected to accumulate adjacent to this travelled portion to the extent that a motorist's sight distance to both the left and right may be greatly reduced or impaired. The snow removed from intersections will be piled in the intersection corners in piles of unequal heights. The line of sight, sight distance, or visibility of motorists approaching these intersections may be greatly reduced or impaired. Jasper County shall not be responsible for snow pushed or otherwise placed on the roadway or shoulders by others. Motorists shall drive their vehicles, during these conditions, with additional caution and watchfulness, especially in respect to the surface of the roadway, and the reduced or impaired visibility, and are advised to reduce their speed at least 25 miles per hour below that legally permitted or advised under normal conditions. In respect to roadways that have only one lane open, further extreme watchfulness and caution must be exercised by the motorists and their speed should not exceed 10 miles per hour. During these conditions, no additional warning or regulatory signs will be placed to warn of impaired sight distances, reduced visibility at intersections, road blockages, one lane conditions, or that the road surface is slick or slippery, or what the advised speed should be.

SECTION 3—SEQUENCE OF SERVICE

In the implantation of snow and ice removal and other maintenance of Jasper County's secondary road system during the winter months, the County Engineer shall select the actual sequence of roads to be cleared, as provided for in this Section of this Policy, and shall determine when drifting snow, wind velocity, and additional snow or snowstorms require that the snow removal equipment be removed from the roadway, or that additional clearance of paved routes be accomplished prior to the clearance of granular surfaced roads. The County Engineer's or his/her designee's professional judgment shall prevail unless it is clearly erroneous.

PAVED ROUTES:

1. The initial effort will be to get all routes open to one lane traffic, as soon as possible following the storm, but in accord with the following Item No. 3.
2. After one lane travel is possible, subsequent snow removal will be carried on during normal working hours.
3. The truck-mounted snowplows and spreaders will not normally be in operation between the hours of 5:30 P.M. and 4:30 A.M. The trucks may be called off the road if snow and blowing reduces visibility to hazardous working conditions, in the professional judgment of the County Engineer or his delegated representative.
4. When required, due to drifting snow, more graders may be used to open, or keep open, the paved roads and the opening of granular surfaced roads may be delayed.
5. The County may place salt, sand, or other abrasives on intersections, hills, and curves after roads have been plowed as provided in this section. These intersections, hills, and curves may not be re-sanded, re-salted, or have other abrasives replaced on them between snowstorms. This sequence of service shall not normally be performed between the hours of 5:30 P.M. and 4:30 A.M. of any day.
6. It is not the policy of Jasper County to provide a "dry" pavement condition.

UNPAVED ROADS:

1. The initial effort will be to open to one lane traffic at least one direction of ingress and egress for each inhabited residence of Jasper County's granular surfaced roads. The roads or portions or roads involved may vary from storm to storm, due to differing characteristics of different storms.
2. After providing all inhabited residences with at least one ingress and egress, these same routes will be widened to two lane travel in preparation for the next snowstorm.
3. Following the opening and widening efforts stipulated above, the remaining unopened granular surfaced roads will be opened to one lane travel.
4. The final step in the sequence of service for unpaved roads will be to widen, to two lane travel, all granular surfaced roads not previously widened.
5. Snow will not be removed from roads designated as Level "B" roads.
6. The motor graders may be called off the road if snow and blowing reduces visibility to hazardous working conditions, in the professional judgment of the County Engineer or his delegated representative.

7. No motor grader snow removal operations will be undertaken on holidays, Saturdays, or Sundays, when the snowfall totals 3 inches, or less, unless drifting snow and blockages of the roads occurs.

PRIVATE DRIVES:

Jasper County will not clear snow from private drives, except for emergencies as defined in Section 5. Normal snow removal operations will result in snow being deposited in private driveways. This deposited snow shall be the responsibility of the resident to remove from the driveway. Snow from private drives shall not be placed on the roadway or shoulders. The resident shall be responsible for the removal of any snow left on the roadway surface or road shoulders due to the clearing of his driveway.

MAILBOXES AND MAILBOX PULLOUTS:

The County shall not replace, or repair mailboxes destroyed or damaged during snow removal operations unless the plow blade actually struck the mailbox. The County will not replace mailboxes damaged or knocked down the force of snow thrown from the plow.

TIME LIMIT:

There is no time limit after a snowstorm in which any of the above sequence of clearance, on paved or unpaved roads, shall take place.

SECTION 4—LIMITATION OF SERVICE

The policy and level of service provided for in this policy shall not include, and the following services shall not be performed:

1. Sanding, salting, or placing of other abrasives upon the roadways or bridges that are slick, slippery, and dangerous due to the formation of frost.
2. Sanding, salting, or placing other abrasives upon paved roadways due to freezing rain that occurs between 5:30 P.M. and 4:30 A.M.
3. Placing of additional warning or regulatory signs warning of impaired sight distances, visibility at intersections, road blockages, one lane conditions, or that the road surface is slick or slippery, or what the advised speed should be.

SECTION 5—EMERGENCY

This sequence of service may be suspended during “Emergency” conditions. An “Emergency” condition shall be considered as one where a loss of life is probable, where a serious injury has occurred, or where extensive loss of property is imminent. These conditions should be verified through a physician’s or sheriff’s office. Jasper County will respond to all “Emergency” conditions, either during or after a snowstorm.

The provisions of this policy shall be further suspended in the event the Governor, by proclamation, implements the State disaster plan, or the Chairman of the Jasper County Board of Supervisors, by proclamation, implements the Jasper County disaster plan. If such occurs, Jasper County personnel and equipment shall be immediately subject to the direction of the Governor or the Chairman of the Jasper County Board of Supervisors.

SECTION 6—SEVERABILITY CLAUSE

Should any section, clause, sentence or provision of this policy be declared, by the courts, invalid for any reason, such declaration shall not affect the validity of this policy as a whole or any part thereof, other than the section, clause, sentence, or provision so declared to be invalid.

Prepared for:
Scott Van
Waardhuizen
JASPER COUNTY
910 N 11th Ave
E
Newton, IA 50208
Phone: (641) 792-5862

Prepared by:
Michael Landau
TRUCK CENTER COMPANIES
101 PLAZA DRIVE
ELK RUN HEIGHTS, IA 50707
Phone: (515) 967-3500

Q U O T A T I O N

WESTERN STAR 47X

SET FORWARD AXLE - TRUCK DETROIT DD13 GEN 5 12.8L 410 HP @ 1625 RPM, 1900 GOV RPM, 1650 LB-FT @ 975 RPM ALLISON 4500 RDS AUTOMATIC TRANSMISSION WITH PTO PROVISION MT-40-14X 40,000# R-SERIES TANDEM REAR AXLE HENDRICKSON HAULMAAX EX 40,000# REAR SUSPENSION	DETROIT DA-F-20.0-5 20,000# FL1 71.0 KPI/3.74 DROP SINGLE FRONT AXLE 20,000# TAPERLEAF FRONT SUSPENSION 111 INCH BBC CONVENTIONAL ALUMINUM CAB 6140MM (242 INCH) WHEELBASE, SFA ONLY 13.0MM X 87.0MM X 311.0MM STEEL FRAME (0.51X3.43X12.24 INCH) 120 KSI 1575MM (62 INCH) REAR FRAME OVERHANG
-------------------------------------------------------------------------------------------------------------------------------------------------------------------------------------------------------------------------------------------------------------------------------------	---------------------------------------------------------------------------------------------------------------------------------------------------------------------------------------------------------------------------------------------------------------------------------------------------------------------

		PER UNIT		TOTAL
VEHICLE PRICE	TOTAL # OF UNITS (3)	\$	135,709	\$ 407,127
EXTENDED WARRANTY		\$	0	\$ 0
DEALER INSTALLED OPTIONS		\$	0	\$ 0
<hr/>				
CUSTOMER PRICE BEFORE TAX		\$	135,709	\$ 407,127
TAXES AND FEES				
TAXES AND FEES	\$		0	\$ 0
OTHER CHARGES	\$		0	\$ 0
TRADE-IN				
TRADE-IN ALLOWANCE	\$		(0)	\$ (0)
<hr/>				
BALANCE DUE	(LOCAL CURRENCY)	\$	135,709	\$ 407,127

COMMENTS:

Projected delivery on ___ / ___ / ___ provided the order is received before ___ / ___ / ___.

APPROVAL:

Please indicate your acceptance of this quotation by signing below:

Customer: X _____ Date: ___ / ___ / ___.



See your local dealer for a competitive quote from Daimler Truck Financial, or contact us at Information@dtfoffers.com.

Daimler Truck Financial offers a variety of finance, lease and insurance solutions to fit your business needs. For more information about our products and services, visit our website at www.daimler-truckfinancial.com.



www.iowadot.gov

Office of Design
800 Lincoln Way | Ames, IA 50010
Phone: 515.460.2953 | Email: tara.vanwaus@iowadot.us

August 9, 2022

Mr. Michael Frietsch, County Engineer
Jasper County Highway Department
910 N 11th Ave E
Newton, IA 50208

Dear Mr. Frietsch:

Congratulations, I'm pleased to inform you that your Fiscal Year (FY) 2023 Living Roadway Trust Fund (LRTF) grant application for HydroSeeder has been approved for funding up to the amount of \$24,000.00.

Project development agreements have been included in this transmittal. Please review these thoroughly to ensure that you understand the grant recipient's responsibilities throughout the project implementation process. After reviewing the agreement, please sign all enclosed copies and return these original copies as soon as possible. As a reminder, city and county recipients are also required to obtain and include a resolution indicating that they are willing to enter into this (or these) grant agreement(s) with the Iowa Department of Transportation (DOT). Once I receive them, I will execute the agreements and send you an authorization to start work, incur costs, and receive reimbursement.

Please send all original copies of the completed agreements to:

Tara Van Waus
Office of Design
Iowa Department of Transportation
800 Lincoln Way
Ames, IA 50010

If you have any questions regarding your grant(s), obtaining a resolution or the processing of paperwork associated with project implementation, please contact me by email at tara.vanwaus@iowadot.us or by phone at 515-460-2953. I look forward to working with you to ensure a successful completion to your FY 2023 LRTF project!

Sincerely,

Tara Van Waus

Tara Van Waus
Living Roadway Trust Fund Coordinator

Enc.: HydroSeeder Project Agreements

IOWA DEPARTMENT OF TRANSPORTATION
Agreement for a Living Roadway Trust Fund Grant
for Counties

RECIPIENT: Jasper County Highway Department

PROJECT NAME: HydroSeeder

AGREEMENT / PROJECT NO.: 90-50-LR23-217

AGREEMENT EXPIRATION DATE: 12/31/2023

Grant Amount:	\$24,000.00
Total Matching Funds:	<u>\$39,830.00</u>
Total Project Cost:	\$63,830.00

Authorizing Official:

Mr. Michael Frietsch
County Engineer
910 N 11th Ave E
Newton, IA 50208
641-792-5862
mfrietsch@jasperia.org

Project Coordinator/Manager:

Mr. Randy Freese
Maintenance Superintendent
910 N 11th Ave E
Newton, IA 50208
641-792-5862
rfreese@jasperia.org

Iowa Department of Transportation:

Ms. Tara Van Waus
Living Roadway Trust Fund Administrator
Office of Design
Highway Division
800 Lincoln Way
Ames, Iowa 50010
Phone - 515-239-1768
Email: tara.vanwaus@iowadot.us

This is an agreement between Jasper County Highway Department (hereinafter referred to as **RECIPIENT**) and the Iowa Department of Transportation (hereinafter referred to as the **DOT**).

RECITALS

1. The **RECIPIENT** submitted an application to the **DOT** for funding through the Living Roadway Trust Fund (LRTF) under Iowa Code section 314 subsection 21, and the application was approved by DOT staff action on August 08, 2022.
2. Pursuant to the terms of this agreement and applicable statutes, the **DOT** agrees to provide funding in the amount of \$24,000.00 to the **RECIPIENT** for the authorized and approved costs for eligible items associated with the development of HydroSeeder. This project shall be completed no later than 12/31/2023 with final request for reimbursement to be received by the **DOT** within ninety (90) days of the completion date. If the **RECIPIENT** requires additional time to fulfill the terms of this agreement, a request for an extension of time shall be submitted to the LRTF Coordinator prior to the expiration date.
3. The Project Coordinator/Manager shall be responsible for reporting in writing to the Living Roadway Trust Fund Coordinator involvement in any projects that are connected in any way to the project outlined in this agreement and receive additional funding from the LRTF or other Resource Enhancement and Protection (REAP) programs. Failure to do so may result in revocation of LRTF funding approval for this project.
4. This agreement shall be executed and delivered in two (2) or more copies, each of which so executed and delivered shall be deemed to be an original and shall constitute but one and the same instrument

In consideration of the foregoing and the mutual promises contained in the agreement, the parties agree as follows:

SECTION 1: AUTHORITY

1. The Authorizing Official and the Project Coordinator/Manager representing the **RECIPIENT** shall be responsible for carrying out the provisions of this agreement.
2. Approval from the **DOT** is required in order to change the Project Coordinator/Manager representing the **RECIPIENT**.
3. It is mutually understood between the parties that the final authority in transportation matters now vested in the **DOT** by federal and state statutory and case law shall not be affected by this agreement.

SECTION 2: GRANT

1. The **RECIPIENT** shall be responsible for the development and completion of the project as described in the application, of which a copy of the original is attached hereto and by this reference incorporated into this agreement as EXHIBIT A.

The Jasper County Highway Department is seeking to replace our 2004 Bowie 1100 HydroSeeder. For nearly 20 years, this piece of equipment has been essential to the maintenance and care of the county right-of-way.

Annually, the Jasper County Highway Department cleans 25 miles of ditch through excavation, bridge replacement, crossroad pipe replacement, or road re-grade projects. After each project is completed, we are committed to using the HydroSeeder to seed the 80 acres of bare soil with native prairie seed we get from the Iowa Living Roadway Trust Fund, as well as seed that is purchased locally, to seed in areas that local farmers mow and spray.

2. Eligible project costs for the project described in section 2, subsection 1 of this agreement, listed above, which are incurred after the effective date of this agreement (see section 5), shall be paid as follows:
3. The portion of the total project costs paid to the **RECIPIENT** shall not exceed \$24,000.00.

RECIPIENT LRTF Funds (Grant):	\$24,000.00
RECIPIENT Local Contribution:	<u>\$39,830.00</u>
LRTF Project Total:	\$63,830.00

4. The local contribution stated above, and in Exhibit A, may include cash or non-cash contributions to the project. The **RECIPIENT** shall certify to the **DOT** the value of any non-cash contribution to the project prior to it being incorporated into the project. For right of way contributions, the **RECIPIENT** shall submit an appraisal and a check appraisal from qualified independent appraisers previously approved in writing by the **DOT**.
5. The **DOT** reserves the right to review the **RECIPIENT**'s certificate of value and has sole authority to determine the value of the **RECIPIENT**'s non-cash contribution for the purposes of this agreement. If, as a result of the **DOT**'s determination, the **RECIPIENT**'s total cash and non-cash contribution is below that stated in the terms of this agreement, the **RECIPIENT** shall increase its cash contribution in order to complete the **RECIPIENT**'s local contribution, or the grant or loan amount associated with this project shall be reduced accordingly.
6. Notwithstanding any other provisions of this contract, if funds anticipated for the continued fulfillment of this contract are at any time not forthcoming or insufficient, either through the failure of the State of Iowa to appropriate funds or discontinuance or material alteration of the program for which funds were provided, the **DOT** shall have the right to terminate this contract without penalty by giving not less than ninety (90) days

written notice. The **DOT** shall reimburse all eligible costs incurred up to and including this notice date.

7. Any revenue generated by interest payments on funds received by the **RECIPIENT** or by sales under this agreement shall be credited to the project.

SECTION 3: WORK

1. The **RECIPIENT** shall conduct the project development and implementation in compliance with applicable laws, ordinances and administrative rules.
2. The **RECIPIENT** shall be responsible for obtaining any permits, such as the Right to Occupy and Perform Work Within the Right of Way, Permit of Access, Utility Accommodation, Right to Install and Maintain Traffic Control Devices, and other construction permits required for the project prior to the start of construction.
3. Neither the approval of the project application for funding nor the signing of this agreement shall be construed as approval of any required permit from **DOT**.
4. In addition, the **RECIPIENT** shall certify to the **DOT's** LRTF Coordinator that all known required environmental clearances have been received and that all environmental regulations have been complied with before funds are reimbursed or credited.
5. Traffic control devices, signing, or pavement markings installed within the limits of this project shall conform to the Manual on Uniform Traffic Control Devices (MUTCD) as adopted pursuant to 761 Iowa Administrative Code (IAC) 130. The safety of the general public shall be assured through the use of proper protective measures and devices such as fences, barricades, signs, flood lighting, and warning lights as necessary.
6. The work on this project shall be in accordance with the grant application, survey, plans, specifications, and estimates on file. Any modification of these documents must be approved by the **DOT** in writing prior to the modification being put into effect.
7. For portions of the project let to bid, the **RECIPIENT** shall advertise for bidders, make a good faith effort to get at least three bidders and hold a public letting for the project work. Prior to awarding the contract, the **RECIPIENT** shall provide the **DOT** file copies of project letting documents within five (5) working days after the letting. The **RECIPIENT** shall wait for **DOT** concurrence before making the final award.
8. The **RECIPIENT** shall include in their Notice to Bidders that Sales Tax Exemption Certificates will be issued, as provided for by Iowa Code section 423.3(80). The **RECIPIENT** shall be responsible for obtaining the sales tax exemption certificates through the Iowa Department of Revenue and Finance. The **RECIPIENT** shall issue these certificates to the successful bidder and any subcontractors to enable them to purchase qualifying materials for the project free of sales tax.

9. The **RECIPIENT** shall use positive efforts to solicit bids from and to utilize Targeted Small Business (TSB) enterprises as contractors and ensure that the contractors make positive efforts to utilize these enterprises as subcontractors, suppliers or participants in the work covered by this agreement.
10. The **RECIPIENT** shall be responsible for the daily inspection of the project. For projects let to contract, the **RECIPIENT** shall compile a daily log of materials and quantities. For projects constructed with local forces, the **RECIPIENT** shall compile a daily log of materials, equipment and labor on the project. The **DOT** reserves the right to inspect project activities and to audit claims for funding reimbursement. The purpose of the inspection or audit is to determine substantial compliance with the terms of this agreement.
11. Originals of all documents including tracings, drawings, estimates, specifications, field notes, investigations, studies, etc., as instruments of service under terms of this agreement, are to be the joint property of the political jurisdiction and governmental agencies participating in the project. Copies of said documents will be made available to such participants upon request.
12. The **RECIPIENT** shall require its contractors to permit the **DOT's** authorized representatives to inspect all work, materials, records, and any other data related to the HydroSeeder project approved and authorized through this agreement.
13. The **RECIPIENT** shall maintain all books, records and accounts, documents, papers, reports, other sources of information, as may be determined by the **DOT** to be pertinent to ascertain compliance with this agreement. The **RECIPIENT** shall also make such materials and its facilities available at all reasonable times during the project agreement period and for three years from the date of final reimbursement, for inspection by the **DOT**. Copies of said materials shall be furnished by the **RECIPIENT** if requested.
14. Project progress reports are due on a quarterly basis in digital format and shall be received by the **DOT** within 30 calendar days of the end of the quarter. For the purposes of this agreement, the quarters for each calendar year shall be January 1 through March 31, April 1 through June 30, July 1 through September 30, and October 1 through December 31.
15. Upon completion of the project described in this agreement, the project coordinator/manager shall submit the final report in digital format to the **DOT** no later than 45 days after the project completion or grant end date, whichever is sooner. For **RECIPIENTs** that have purchased equipment, the project coordinator/manager shall submit the final report to the **DOT** no later one (1) year after the purchase date of said equipment. A presentation at the soonest statewide IRVM meeting on the performance of the equipment is also required within this same time period. Where any information required of the **RECIPIENT** is in the exclusive possession of another who fails or refuses to furnish this information, the **RECIPIENT** shall so certify to the **DOT** and shall set forth what efforts it has made to obtain the information. Work performed under the provisions of this agreement shall be maintained into perpetuity.

SECTION 4: PROPERTY AND EQUIPMENT

1. In the event that right of way is required for the project, said right of way will be acquired in accordance with 761 IAC 111, Real Property Acquisition and Relocation Assistance, and the Federal Uniform Relocation Assistance and Real Property Acquisition Policies Act of 1970, as amended.
2. When property and equipment is purchased with LRTF funds, the **RECIPIENT** agrees that the property and equipment shall be used for the provision of integrated roadside vegetation management; within roadside rights-of-way or areas approved in writing by the **DOT**, for the life of the property and equipment as determined by the **DOT**. Title to all property and equipment purchased pursuant to the agreement shall rest with the **RECIPIENT** of this agreement.
3. The **RECIPIENT** shall permit the **DOT** or its authorized representatives to inspect all property and equipment purchased or used to comply with this agreement.
4. The **RECIPIENT** agrees, within 45 days of acceptance of equipment financed through this agreement, to submit an inventory report including photographs of equipment purchased with LRTF labels adhered in prominent locations to four sides of the equipment.
5. If the property and equipment is not continuously used for vegetation management in the rights-of-way in a manner described by the application and the guidelines for the LRTF program, the **RECIPIENT** shall immediately notify the **DOT**. If the property and equipment is not maintained in a usable condition, it shall be considered to not be in continuous use. The **DOT** shall then determine whether the property and equipment should be transferred to another LRTF recipient for continued use. If the **DOT** determines there is no need for the property and equipment among other LRTF recipients, the **DOT** may authorize local disposal through sale.
6. If the property and equipment is sold, it shall be sold by the **RECIPIENT** at the highest price obtainable at public or private sale, subject to written approval of the sale price by the **DOT**.

SECTION 5: REIMBURSEMENT

The **DOT** reimburses for expenses up to the limits described in this agreement as follows:

1. The **RECIPIENT** has specified that they will submit periodic reimbursement requests One Time (at Conclusion of Project).

2. All costs submitted for reimbursement or to be counted as matching funds shall not be incurred until after this agreement is fully executed by the **DOT**.
3. Prior approval by the **DOT** is required before there can be any change to the scope of work and budget in the grant application approved by the **DOT**. For any individual work plan item not implemented by the **RECIPIENT** prior to the expiration date of this agreement, there will be no reimbursement by the **DOT**.
4. All reimbursement requests and direct vendor payment requests shall be submitted to the **DOT** using form 841700 Claim for Reimbursement of Living Roadway Trust Fund Project Costs located on the **DOT** website at <https://forms.iowadot.gov/BrowseForms.aspx> and attached as EXHIBIT B. Reimbursement requests and direct vendor payment requests submitted without form 841700 properly completed or without the required documentation of costs incurred shall be returned to the **RECIPIENT** without being processed with a request for correction and resubmittal.
5. For each work plan item of this agreement the **DOT** will, upon receipt of appropriate request and sufficient documentation, reimburse the **RECIPIENT** for the lesser of the amount established in this agreement or the actual expense. Any cost overruns shall be paid solely by the applicant.
6. The **RECIPIENT** may submit to the **DOT** periodic itemized claims for reimbursement for eligible project costs as often as monthly but no less than quarterly unless a one-time reimbursement or direct vendor payment option is indicated on the grant application. Periodic reimbursement requests shall be received by the **DOT** no later than 45 days after the end of the month or end of the quarter, whichever has been indicated in this agreement by the **RECIPIENT** in section 5 subsection 1. Reimbursement claims shall include an original signature certification that all eligible project costs, for which reimbursement is requested, have been completed in substantial compliance with the terms of this agreement.
7. All requests for reimbursement must be itemized by work plan item, hours, pay classification, direct expenses and indirect expenses as applicable so as to allow the **DOT** to verify that the costs submitted conform to the items as outlined in this agreement.
8. Quarterly reimbursement requests shall include the status of all work plan items present in the approved application and agreement. Payment will be withheld until the status report is received in digital format.
9. All **RECIPIENTS** requesting reimbursement of indirect costs shall submit a current approved cost allocation plan or federally approved indirect cost rate documentation approved by the **DOT**.
10. All requests for reimbursement of equipment acquired as provided for in section 4 of this agreement must be accompanied by a copy of an invoice from the vendor. All original

invoices must be received and reviewed by the **RECIPIENT** and verification of correct quantities and costs for items received must be indicated. The **RECIPIENT** shall sign, print their name and date the invoice to certify that receipt of the indicated invoice items has taken place.

11. The **DOT** shall reimburse the **RECIPIENT** for properly documented and certified claims for eligible construction project activity costs, less a retainage, if applicable to the project, of not more than ten percent, either by state warrant, or by crediting other accounts from which payment may have been made initially. If, upon audits of contracts, the **DOT** determines the **RECIPIENT** is overpaid, the **RECIPIENT** shall reimburse the overpaid amount to the **DOT**.
12. Upon completion of the project described in this agreement, the project coordinator/manager of the grant project shall certify in writing by letter to the **DOT** that the project activities were completed in substantial compliance with the requirements set forth in this agreement. Final reimbursement shall be made only after the **DOT** accepts the project as complete. In order to be considered complete, the provisions set forth in section 3 subsection 15 of this agreement must be met.
13. Final reimbursement requests by the **RECIPIENT** to the **DOT** shall be received no later than ninety (90) days after the completion of the project or the expiration date of this agreement, whichever is sooner. Failure to submit requests by this time, without prior approval, shall result in loss of remaining grant funding.
14. The **DOT** reserves the right to delay reimbursement of funds to the **RECIPIENT** if necessary to maintain a positive cash flow. If such a delay is necessary and lasts more than five working days, the **DOT** shall so notify the **RECIPIENT** in writing and shall give the **RECIPIENT** an estimate of when reimbursement might be expected. The **DOT** shall establish a system to equitably make reimbursements to all **RECIPIENT**s so affected.

SECTION 6: SUBMITTALS

1. Papers, interim reports, forms, or other materials, which are a part of the work set forth in this agreement, shall not be copyrighted without written approval of the **DOT**. If written approval is given, such approval shall be subject to all applicable federal and state laws, rules and regulations.
2. Publications by either party shall give credit to the other party. However, if the **DOT** does not wish to subscribe to the findings or conclusions of the study, the following statement shall be included on the credit sheet: "The opinions, findings, and conclusions expressed in this report are those of the authors, who are responsible for the facts and accuracy of the material presented herein. The contents do not necessarily reflect the official views, policies, or conclusions of the **DOT**". It is the responsibility of the **RECIPIENT** to contact the **DOT** to ascertain the stance **DOT** wishes to take before the credit sheet is prepared.

3. Either party to this agreement may initiate a request for publication of the final or interim reports, or any portions thereof.

SECTION 7: DEFAULT

1. This agreement may be declared to be in default by the **DOT** if the **DOT** determines that the **RECIPIENT's** application for funding contained inaccuracies, omissions, errors or misrepresentations; or if the **DOT** determines that the project is not being developed as described in the application.
2. If the **RECIPIENT** fails to perform any obligation under this agreement, the **DOT** shall have the right, after first giving thirty (30) days written notice to **RECIPIENT** by certified mail return receipt requested, to declare this agreement in default. The **RECIPIENT** shall have thirty (30) days from date of mailing of notice to cure the default. If the **RECIPIENT** claims to have cured the default, it shall notify **DOT** no later than five (5) days after taking the action it claims has cured the default. **DOT** shall have sole discretion, without further notice, to determine whether or not any action taken has cured the default.
3. In the event a default is not cured, the **DOT** may revoke funding commitments and seek repayment of funds loaned or granted by this agreement. By signing this agreement, the **RECIPIENT** agrees to repay said funding if they are found to be in default. Repayment methods must be approved by the **DOT** and may include cash repayment, installment repayments with negotiable interest rates, charges against the **RECIPIENT's** share of road use tax funds, or other methods as approved by the **DOT**.

SECTION 8: GENERAL

1. All notices required under this agreement shall be made in writing to the **DOT's** and the **RECIPIENT's** contact person. The **DOT's** contact person shall be Tara Van Waus, Living Roadway Trust Fund Coordinator, Iowa Department of Transportation, Office of Design, 800 Lincoln Way, Ames, Iowa, 50010, phone: 515-239-1768, email: tara.vanwaus@iowadot.us. The **RECIPIENT's** contact person shall be Mr. Randy Freese Maintenance Superintendent, Jasper County Highway Department 910 N 11th Ave E Newton, IA 50208 641-792-5862 rfreese@jasperia.org.
2. The **RECIPIENT** agrees to defend, indemnify and hold **DOT** harmless from any and all liability arising out of or relating in any manner to the above-referenced project, including any and all suits, actions, or claims of any character arising out of or relating in any manner to the above-referenced project, including as well, but not limited to, matters relating to research, purchase of equipment, representation of the LRTF program at public events and the design, construction, maintenance, placement of traffic control devices, or inspection of the work associated with this project. This agreement to

indemnify, defend and hold harmless applies to all aspects of the **DOT**'s application review and approval process, work plan review and guidance, plan and construction reviews, and funding participation. It includes but is not limited to claims for acts and omissions for which the **DOT** alone was or would be responsible.

3. The **RECIPIENT** shall comply with all provisions of the equal employment opportunity requirements prohibiting discrimination and requiring affirmative action to assure equal employment opportunity as required by Iowa Code chapter 216, the Iowa Civil Rights Act of 1965. No person shall, on the grounds of age, race, creed, sex, color, national origin, religion, or disability, be excluded from participation in, be denied the benefits of, or be otherwise subjected to discrimination under any program or activity for which the **RECIPIENT** receives state funds from the **DOT**.
4. All accounting practices applied, and all records maintained will be in accordance with generally accepted accounting principles and procedures.
5. If any part of this agreement is found to be void and unenforceable then the remaining provisions of the agreement shall remain in effect.
6. This agreement is not assignable without the prior written consent of the **DOT**.
7. It is the intent of both parties that no third-party beneficiaries be created by this agreement.
8. This agreement as set forth in sections 1 through 9 herein, including referenced **EXHIBITs**, constitutes the entire agreement between the **DOT** and the **RECIPIENT** concerning this project. Representations made before the signing of this agreement are not binding, and neither party has relied upon conflicting representations in entering into this agreement. Any change or alteration to the terms of this agreement must be made in the form of an addendum to this agreement. Said addendum shall become effective only upon written approval of the **DOT** and **RECIPIENT**.

EXHIBIT A
Recipient Grant Application

LIVING ROADWAY TRUST FUND GRANT APPLICATION

Deadline: June 1st, 2022 4:00 p.m.

Read Application Instructions and FY 2023 Funding Guidelines before completing application.

Project Name:

APPLICANT INFORMATION

Grant Applicant (Agency, Organization, County...):

Applicant Authorizing Official: Position/Title:

Title: First Name: Last Name:

Address 1:

Address 2:

Address 3:

City: State: ZIP Code:

E-mail: Phone: Fax:

Project Coordinator/Manager: Position/Title:

Title: First Name: Last Name:

Address 1:

Address 2:

Address 3:

City: State: ZIP Code:

E-mail: Phone: Fax:

NOTIFICATION FOR WORK IN RIGHT-OF-WAY (PLANTING) PROJECTS

If applicable, select the type of right-of-way in which the proposed project will occur:

Jurisdiction representative who has been notified of the project proposal:

Name: Title:

E-mail: Phone:

Have all required permits, environmental clearances, easements and notifications been made or acquired?

If no, please explain:

PROJECT INFORMATION

Project Funding Category: Grant Applicant Type:

Project Type:

If Other Related Project type was selected please explain:

Estimated Start Date (MM/DD/YYYY): Estimated Completion Date (MM/DD/YYYY):

Concise Project Summary:

The Jasper County Highway Department is seeking to replace our 2004 Bowie T100 HydroSeeder. For nearly 20 years, this piece of equipment has been essential to the maintenance and care of the county right-of-way.

Annually, the Jasper County Highway Department cleans 25 miles of ditch through excavation, bridge replacement, crossroad pipe replacement, or road re-grade projects. After each project is completed, we are committed to using the HydroSeeder to seed the 80 acres of bare soil with native prairie seed we get from the Iowa Living Roadway Trust Fund, as well as seed that is purchased locally, to seed in areas that local farmers mow and spray.

Detailed Project Description:

The Jasper County Highway Department oversees the maintenance and care of approximately 10,000 acres of right-of-way. For nearly 20 years, we have been using our 2004 Bowie 1100 HydroSeeder to help us re-seed these right-of-way after any project that involves the removal or major disturbance of native vegetation. Through the years, we have been able to perform routine maintenance and some major overhauls to keep our current machine in working order, however with its age and frequent usage, we are finding that it is nearing the end of its useful life.

We have received quotes from two (2) suppliers for a new HydroSeeder with mechanical agitation. A quote for a new Bowie 1100 model came in at \$63,830 and a quote for a new Finn Model T120 came in at \$87,795. The machines are very comparable in operations and serviceability.

Given that we have had great success over the last 20 years, as well as the price difference, we plan to purchase another Bowie 1100. We have been able to use our current machine to its full capacity and have made great progress in ensuring that our county right-of-ways are seeded and growing native vegetation. With a new machine, we are confident that we can continue to do so for the next 20 years.

*Note: No ILRTF funds were used to purchase our current Bowie 1100 HydroSeeder.

PROJECT COST SUMMARY

Line #	Detailed Work Plan (Please include all workplan items to detail total project cost, including all match amounts)	Amount
<input type="checkbox"/>	Bowie 1100 HydroSeeder with Mechanical Agitation	\$63,830.00
<input type="checkbox"/>		
<input type="checkbox"/>		
<input type="checkbox"/>		
<input type="checkbox"/>		
<input type="checkbox"/>		
<input type="checkbox"/>		
<input type="checkbox"/>		
<input type="checkbox"/>		
<input type="checkbox"/>		
<input type="checkbox"/>		
<input type="checkbox"/>		
<input type="checkbox"/>		
<input type="checkbox"/>		
<input type="checkbox"/>		
<input type="checkbox"/>		
<input type="checkbox"/>		
<input type="checkbox"/>		
<input type="checkbox"/>		
<input type="checkbox"/>		

Total Project Cost: \$63,830.00

MATCH SUMMARY

Line #	Cash Match Detail (Please include all cash match items found in the previous section)	Amount
<input type="checkbox"/>	Local Funds	\$39,830.00
<input type="checkbox"/>		
<input type="checkbox"/>		
<input type="checkbox"/>		
<input type="checkbox"/>		
Total Cash Match Amount:		\$39,830.00

Line #	In-Kind Match Detail (Please include all in-kind match items found in the previous section)	Amount
<input type="checkbox"/>		
<input type="checkbox"/>		
<input type="checkbox"/>		
<input type="checkbox"/>		
<input type="checkbox"/>		
Total In-Kind Match Amount:		0
Total Grant Match Amount:		39830

GRANT REQUEST SUMMARY

Total Project Cost: \$63,830.00

Total Matching Funds: \$39,830.00

Grant Match Percentage: 62%

Grant Amount Requested: \$24,000.00

(Enter the amount of the grant for which you are applying)

Reimbursement Frequency: One Time (at Conclusion of Project)

Minority Impact Statement

Pursuant to 2008 Iowa Acts, HF 2393, Iowa Code Section 8.11, all grant applications submitted to the State of Iowa that are due beginning January 1, 2009, shall include a Minority Impact Statement. This is the state's mechanism for requiring grant applicants to consider the potential impact of the grant project's proposed programs or policies on minority groups.

Please choose the statement(s) that pertains to this grant application. Complete all the information requested for the chosen statement(s). Submit additional pages as necessary.

- The proposed grant project programs or policies could have a disproportionate or unique **positive** impact on minority persons.

Describe the positive impact expected from this project:

Indicate which groups are impacted:

- Women Persons with a disability Blacks Latinos Asians
 Pacific Islanders American Indians Alaskan Native Americans Other

- The proposed grant project programs or policies could have a disproportionate or unique **negative** impact on minority persons.

Describe the negative impact expected from this project:

Present the rationale for the existence of the proposed program or policy:

Provide evidence of consultation with representatives of the minority groups impacted:

Indicate which groups are impacted:

- Women Persons with a disability Blacks Latinos Asians
 Pacific Islanders American Indians Alaskan Native Americans Other

The proposed grant project programs or policies are **not expected to have** a disproportionate or unique impact on minority persons.

Present the rationale for determining no impact:

The use of a HydroSeeder for roadside management is beneficial to all residents and visitors to Jasper County, including minority groups.

I hereby certify that the information on this form is complete and accurate, to the best of my knowledge:

Name: Nicole Williams

Title: Office and Finance Manager

Definitions

"Minority Persons", as defined in Iowa Code Section 8.11, means individuals who are women, persons with a disability, Blacks, Latinos, Asians, or Pacific Islanders, American Indians, and Alaskan Native Americans.

"Disability", as defined in Iowa Code Section 15.102, subsection 7, paragraph "b", subparagraph (1):

b. As used in this subsection:

- (1) "*Disability*" means, with respect to an individual, a physical or mental impairment that substantially limits one or more of the major life activities of the individual, a record of physical or mental impairment that substantially limits one or more of the major life activities of the individual, or being regarded as an individual with a physical or mental impairment that substantially limits one or more of the major life activities of the individual.

"*Disability*" does not include any of the following:

- (a) Homosexuality or bisexuality.
(b) Transvestism, transsexualism, pedophilia, exhibitionism, voyeurism, gender identity disorders not resulting from physical impairments or other sexual behavior disorders.
(c) Compulsive gambling, kleptomania, or pyromania.
(d) Psychoactive substance abuse disorders resulting from current illegal use of drugs.

"State Agency", as defined in Iowa Code Section 8.11, means a department, board, bureau, commission, or other agency or authority of the State of Iowa.

APPLICATION CERTIFICATION:

I, the undersigned, certify that this project has been approved for submittal for Living Roadway Trust Fund grant consideration.

Grant Applicant (Agency, Organization, County...): Jasper County Highway Department

Applicant Authorizing Official: Position/Title: County Engineer

Title: Mr. First Name Michael Last Name Frietsch

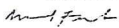
signed via SeamlessDocs.com

Key: 6181d476976eab7e1c64936cdd5e076

05/31/2022

Submission Checklist:

- Iowa DOT Form 841702 (pages 1-5 and 8 of this document)
- Minority Impact Statement Form 105101 (pages 6 & 7 of this document)
- Supplemental Supporting Information
(Please attach using paperclip symbol on the upper left side of this document; if you have more than one document please merge all documents into one pdf prior to attaching to grant application.)

Midwest Bowie Sales
18 Yerger Rd
Absarokee, MT 59001 US
barchl@aol.com

Estimate



ADDRESS
Jasper County Hwy Dept
910 N 11th Ave E
Newton, IA 50208

SHIP TO
Jasper County Hwy Dept
Jasper County Engineer's Office
910 N. 11th Ave E
Newton, IA 50208

ESTIMATE # DATE
1052 01/25/2022

PLEASE DETACH TOP PORTION AND RETURN WITH YOUR PAYMENT.

DATE	ACTIVITY	DESCRIPTION	QTY	RATE	AMOUNT
	1100T	1100 Gallon Bowie Hydromulcher, Trailer Mounted,Pintle hitch,47 HP Yammer Diesel engine. Bowie gear pump.	1	61,830.00	61,830.00
Shipping estimate is \$2000.00 to Newton, IA.				SUBTOTAL	61,830.00
IRVM Discount of \$2820.00 applied .				SHIPPING	2,000.00
				TOTAL	\$63,830.00

Accepted By

Accepted Date

Jasper County Secondary Roads		Randy Freese		5/17/2022	
910 N 11th Ave East		Salesman Don Slycord		Phone # 641-521-3427	
Newton	State Iowa	Zip 50208	County Jasper		

NO DELIVERY OF GOODS TO BE MADE UNTIL FULL SETTLEMENT IS RECEIVED

Year NA	Make Finn	Model T120T	Serial # NA	Hours NA
------------	--------------	----------------	----------------	-------------

Machines and Attachments	Price	\$	87,795.00
---------------------------------	--------------	-----------	------------------

1 HYDRO SEEDER

0 Gallon Liquid capacity/1000 Gallon working capacity

orsepower Yanmar Tier4 Diesel

3 RAIL: Operator platform/discharge gun/Guard rails

OWER: 1 Wide fan/1 Narrow fan/2 Long distance

ound level

r with electric brakes and DOT Lights

EQUIPMENT:

ubber supply hose, 2 Control valves, 3 Nozzles \$977.00

YEAR 2000 HOUR PARTS/IN SHOP LABOR

QUOTES VALID 7 DAYS

We appreciate the opportunity to quote you and look forward to serving your equipment needs.

Equipment

S	Description			Trade Allowance	Amount Owing	Net Trade Allowance	Owed to Whom	Note #
	Make	Model	Serial Number					
				\$ -	\$ -	\$ -	\$ -	
				\$ -	\$ -	\$ -	\$ -	
				\$ -	\$ -	\$ -	\$ -	
	Total Trade Allowance			\$ -	\$ -	\$ -	\$ -	

		1. Selling Price	\$	87,795.00
	\$ -	2. Rental Credit (per left column)	\$	-
arranty	\$ -	3. Trade Allowance (per above)	\$	-
e Plan	\$ -	4. Net Price (1-2-3)	\$	87,795.00
nage Insurance	\$ -	5. Federal Excise	\$	-
Fees (1+2+3+4)	\$ -	6. Iowa Tax	0%	\$ -
alculation		7. South Dakota/Nebraska Tax	0%	\$ -
	0	8. Balance Owed On Trade	-	\$ -
ntal Rate	\$ -	9. Cash with Order	\$	-
(1x2)	\$ -	10. Other Fees (LH Couolumn)	\$	-
nted	0%	11. Balance Due 5+6+7+8+10	\$	87,795.00
it (3x4)	\$ -	Terms		

Cash on Delivery
Retail Installment Contract

If retail contract, indicate desired length of contract

FINN

HydroSeeder®

Model T120

T120 HydroSeeder Gooseneck Trailer. (T120GN)



The FINN T120 HydroSeeder is a real workhorse with a 1,000 gallon working tank capacity. FINN developed HydroSeeder technology in 1953. We've been the industry leader in quality and innovation ever since. With the FINN T120, you don't have to settle for less than proven FINN quality to tackle a wide range of highly demanding hydroseeding applications.

Power To Spare.

The T120 provides muscle with a rugged and dependable 35.1 hp, 3 cylinder water cooled Yanmar diesel engine. Available in skid, gooseneck trailer, or straight pull trailer configurations, the T120 HydroSeeder covers up to 1/3 of an acre with one full tank. Tower discharge distance reaches up to 180 feet for greater slurry application and efficient coverage. In addition, the T120 is equipped with full deck railing and plenty of storage capacity to carry extra materials.

Positive Control.

The FINN T120 HydroSeeder features a heavy-duty agitator driven by a variable speed, reversible hydraulic motor. The agitator and pump are independently driven, allowing for complete mixing of the slurry without pump operation, and FINN's direct drive clutch and pump assembly are specifically designed to optimize horsepower efficiency and maximize pump performance.

Other features include independent rubber torsion suspension

axles that are equipped with electric brakes, including break-away switch; and a direct drive clutch with an adjustable external wear plate.

As the world leader for over 80 years in the design and manufacture of innovative, quality equipment for the green industry, and as the inventor of the HydroSeeder, FINN Corporation is committed to your complete satisfaction.



T120 HydroSeeder Straight Pull Trailer. (T120T)

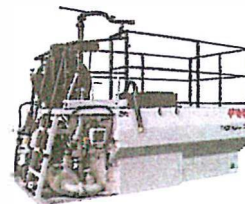

T120 HydroSeeder Skid Mounted. (T120S)

Models shown include optional equipment.

FINNcorp.com

FINN
SMARTER WAYS TO WORK

FINN HydroSeeder®

Model T120 with Tier 4F Engine

T120GN GOOSENECK TRAILER

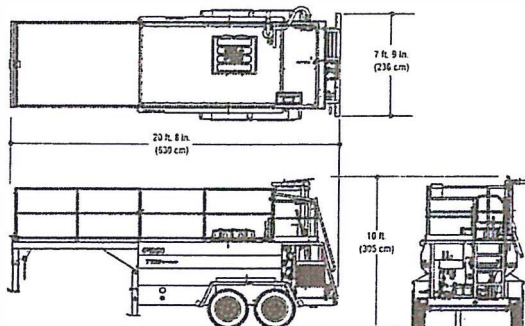

T120T STRAIGHT PULL TRAILER

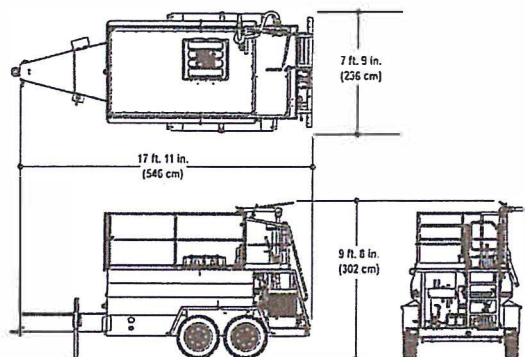

T120S SKID MOUNT

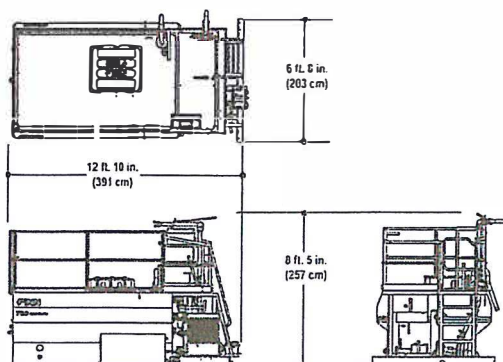

FINN MODEL T120 TECHNICAL SPECIFICATIONS

POWER	Yanmar 3TNV88C-DYEM, 35.1hp (26.2kw), 3 cylinder water cooled diesel engine. Tier 4Final. 1.642L
ENGINE SAFETY SYSTEM	Low oil pressure, electronic engine control and monitoring
TANK SIZE	1,180 gallon (4,468 liter) liquid capacity, 1,000 gallon (3,785 liter) working capacity
LOADS PER ACRE ¹	3
FUEL TANK CAPACITY	13.5 gallon (51.1 liter)
PUMP	Centrifugal 4" x 2" (10 cm x 5 cm) 170 gpm @ 100 psi (646 lpm @ 7 kg/cm ²), 3/4" (1.9 cm) solid clearance, external adjustment
PUMP DRIVE	Direct drive with over center clutch, pump drive is independent of agitator operation
AGITATION	Mechanical paddle agitation and liquid recirculation
AGITATOR DRIVE	Reversible, variable speed hydraulic motor drive (0-100 rpm)
DISCHARGE DISTANCE	Up to 180 feet (55 m) from end of discharge tower
MAX. MATERIAL CAPACITY	3,200 lbs. (1,450 kg) granular solids 500 lbs. (225 kg) fiber mulch
NOZZLES	(1) narrow fan, (1) wide fan, (2) long distance
EMPTY WEIGHT ²	T120GN 7,010 lbs. (3,180 kg) T120T 6,170 lbs. (2,799 kg) T120S 4,580 lbs. (2,077 kg)
WORKING WEIGHT ²	T120GN 18,730 lbs. (8,496 kg) T120T 17,900 lbs. (8,119 kg) T120S 16,300 lbs. (7,394 kg)
BRAKES	Electric on both axles with break-away switch
LIGHTS	D.O.T. including marker, identification lights and license plate bracket
TIRES	ST235/85R16 radial, load range E
TRAILER AXLES	Tandem 7,200 lbs. (3,266 kg) rubber torsion with fenders
GVWR	T120GN 17,900 lbs. (8,119 kg) T120T 17,200 lbs. (7,802 kg)
HITCH WEIGHT	T120GN Approx. 3,500 lbs. (1,588 kg) T120T Approx. 2,800 lbs. (1,270 kg)

¹Loads per acre based on an application rate of 1500 lbs. mulch/acre.

²Working weights are approximate and do not include options or stored materials. Working weights assume maximum tank liquid capacity and maximum granular solids material capacity.

FINN Corporation has a policy of continuous product improvement, and reserves the right to change design and specifications without notice.

HydroSeeder® and the FINN Design® Logo are registered trademarks of FINN Corporation.



9281 LeSaint Drive • Fairfield, OH 45014-5457
Toll Free 800.543.7166 / 513.874.2818
FINNcorp.com

W22 Hydro Seeding

HIGHWAY AND TRANSPORTATION MAP

JASPER COUNTY
IOWA

Prepared by
 IOWADOT

1572045 PLANNING DIVISION
Phone: (515) 281-1444
www.iowadot.com/imap/

In Cooperation With
United States
Department of Transportation

JANUARY 1, 2019



LEGEND

- | | |
|---------------------------|------------------------------------|
| MAJOR HIGHWAY | [Thick solid line] |
| STATE ROAD | [Thin solid line] |
| UNIMPROVED ROAD | [Dashed line] |
| ROAD UNDER CONSTRUCTION | [Double line] |
| RAILROAD | [Cross-hatched pattern] |
| INTERSTATE HIGHWAY | [Thick solid line with 'I' shield] |
| STATE HIGHWAY | [Thin solid line with 'S' shield] |
| UNIMPROVED ROAD | [Dashed line with 'U' shield] |
| RAILROAD | [Cross-hatched pattern] |
| RAILROAD CROSSING | [Cross-hatched pattern with 'X'] |
| RAILROAD BRIDGE | [Cross-hatched pattern with 'B'] |
| RAILROAD TUNNEL | [Cross-hatched pattern with 'T'] |
| RAILROAD GRADE SEPARATION | [Cross-hatched pattern with 'G'] |
| RAILROAD AT GRADE | [Cross-hatched pattern] |
| RAILROAD UNDERPASS | [Cross-hatched pattern with 'U'] |
| RAILROAD OVERPASS | [Cross-hatched pattern with 'O'] |

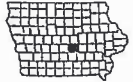
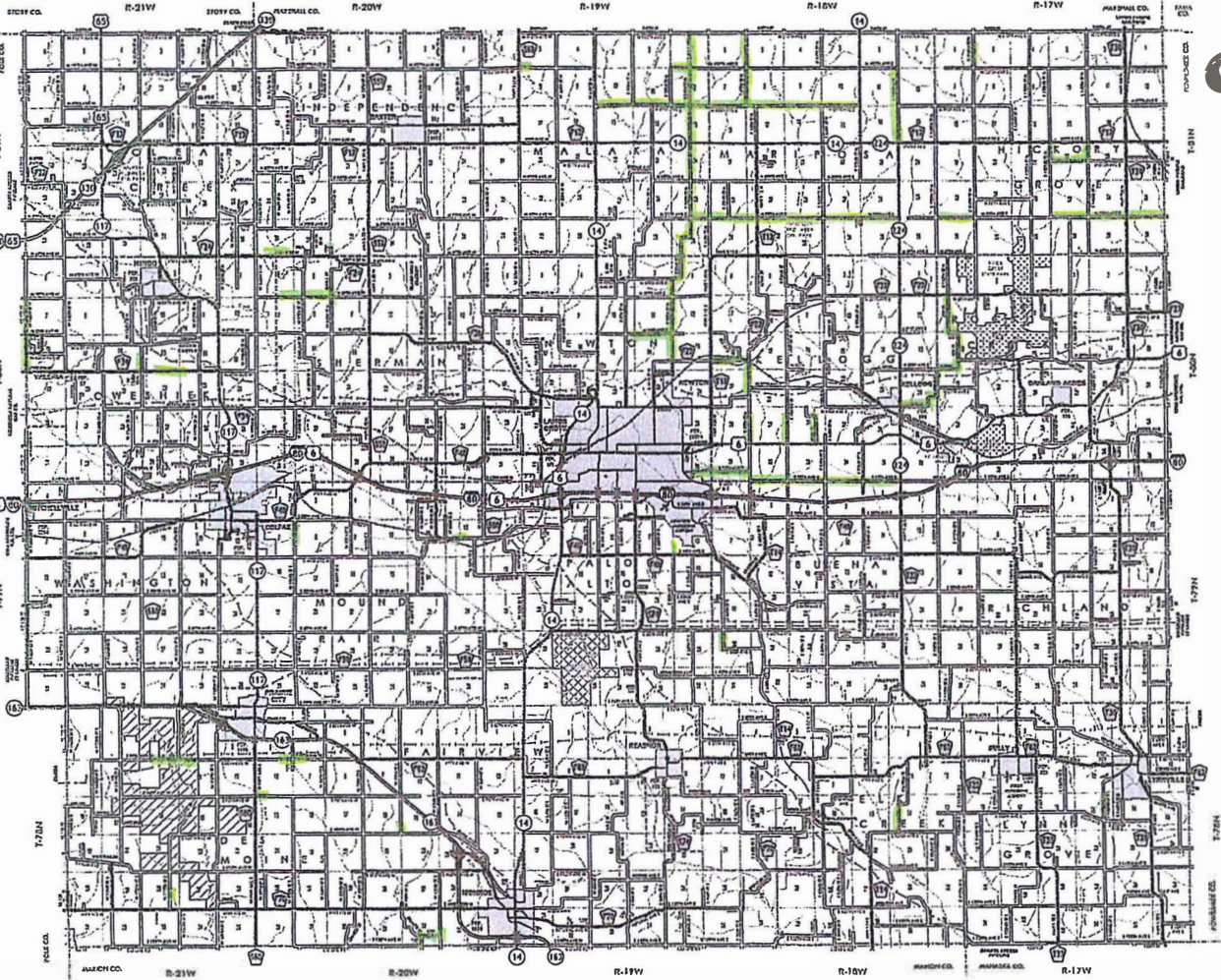

EXHIBIT B
Reimbursement Form

**Instructions for completing Form 841700
REQUEST FOR REIMBURSEMENT OF LIVING ROADWAY TRUST FUND GRANT PROJECT COSTS
AND
DIRECT VENDOR OR SERVICES PAYMENTS**

This form is for documenting eligible costs that are to be: (1) reimbursed to the grant Recipient for costs already incurred, (2) requested to be paid directly to a vendor as a direct vendor payment after the equipment has been received and checked in on the invoice as required or (3) payment for services, including direct and indirect costs, as indicated in the project agreement. Each type has a separate line for data entry.

Please Use the Tab key on your keyboard to scroll through and fill in all appropriate information in the shaded entry fields on the form(s).

Claim Number: Enter the claim number. The first claim for a unique project number is Claim 1, the next for the same project is Claim 2 and so on.

Check the checkbox with the computer mouse for final reimbursement when completing the final reimbursement claim.

Date: Enter the date the claim is prepared.

Enter the Iowa DOT Project Number, Grant Recipient and Project Name as they are indicated in the project agreement.

Line 1. Enter the Grant Amount (maximum state funds payable per the Iowa DOT project agreement).

Line 2. If applicable, enter the amount of "Local Contribution" included in the total project cost. The local contribution amount is the combination of in-kind and organization funds contributed to the project.

Line 3. This is the sum of the Grant Amount, the in-kind contribution and the local contribution. This field is automatically calculated.

Line 4. Enter the dollar amount of *eligible* costs requested for Reimbursement of Grant Items costs incurred by the Recipient for this claim in Column A. Enter the total cumulative dollar amount of *eligible* costs requested for Reimbursement of Grant Items costs incurred by the Recipient to date, including this claim, in Column B. These amounts should not include any match percentage.

Line 5. Enter the dollar amount of *eligible* costs requested for Direct Vendor Payments for this claim in Column A. Enter the total cumulative dollar amount of *eligible* costs requested for Direct Vendor Payments to date, including this claim, in Column B. Each Direct Vendor Payment request should use a separate request form and should only include costs for a single vendor. These amounts should not include any match percentage.

Line 6. This is the Subtotal dollar amount of *eligible* costs requested for Reimbursement of Grant Item costs incurred by the Recipient and costs requested for Direct Vendor Payments. This field is automatically calculated.

Line 7. Enter the dollar amount paid by the Iowa DOT for eligible costs requested for Reimbursement of Grant Items and costs requested for Direct Vendor Payments prior to this claim.

Line 8. This is the subtotal dollar amount due this payment/final payment for Reimbursement of Grant Item costs incurred by the Recipient and costs requested for Direct Vendor Payments. This field is automatically calculated.

Line 9. Enter the dollar amount of *eligible* Indirect and Direct costs requested for Services costs for this claim in the appropriate field in Column A. Enter the total cumulative dollar amount of *eligible* Indirect and Direct costs requested for Services costs incurred by the Recipient to date, including this claim in the field in Column B. These amounts should not include any match percentage.

Line 10. This is the subtotal dollar amount eligible for Services Costs. This field is automatically calculated.

Line 11. Enter the dollar amount paid by the Iowa DOT for eligible Services Costs prior to this claim.

Line 12. This is the subtotal dollar amount due this payment/final payment for Services Costs. This field is automatically calculated.

Line 13. This is the total dollar amount due for Reimbursement of Grant Items costs incurred by the Recipient, costs requested for Direct Vendor Payments and Services Costs for this claim. This field is automatically calculated.

NOTE: Reimbursement claims must include a completed original signed reimbursement claim form (841700), copies of all invoices (with beginning and ending dates), proof of processed payment and/or in-kind contribution documentation totaling 100% of the amount of work for which reimbursement is being requested. Direct vendor payment requests must be accompanied by a vendor invoice with the items received circled, signature and printed name of the authorized person who received the invoiced item(s) and the date received.

Submit an electronic version of this form and required documentation via email to lrf.support@iowadot.us for review. Upon approval, mail the signed original and required documentation to: LRTF Program Coordinator, Office of Design, Iowa Department of Transportation, 800 Lincoln Way, Ames, Iowa 50010

REQUEST FOR REIMBURSEMENT OF LIVING ROADWAY TRUST FUND GRANT PROJECT COSTS AND DIRECT VENDOR OR SERVICES PAYMENTS

*** PLEASE READ THE INSTRUCTIONS FOR COMPLETING THIS FORM BEFORE YOU PROCEED***

Project Information

Claim Number: _____ Check for Final Reimbursement Date: _____ Iowa DOT Project Number: _____
 Grant Recipient: _____
 Project Name: _____

1	Grant Amount: Maximum State Funds payable per the Iowa DOT project agreement	\$0.00
2	Local Contribution (including in-kind and organization funds contributed to the project if applicable):	\$0.00
3	Total Project Cost: Total of lines 1 and 2	\$0.00

Grant Items for Reimbursement to the Recipient and Costs Paid Directly to Vendor

		This Claim Amount [A]	Cumulative Claim Amount [B]
Grant Items to be Reimbursed to the Recipient			
4	Amount of Grant Item costs claimed: For this claim [A] and cumulative [B]	\$0.00	\$0.00
Grant Items to be Paid Directly to Vendor			
5	Amount of Vendor invoice(s): For this claim [A] and cumulative [B]	\$0.00	\$0.00
6	Subtotal amount eligible for Reimbursement and Direct Vendor Payments	\$0.00	\$0.00
7	Amount paid by the Iowa DOT for Reimbursement and Direct Vendor payments prior to this claim:	\$0.00	\$0.00
8	Subtotal amount due this payment/final payment for Reimbursement and Direct Vendor Payments:	\$0.00	\$0.00

Services Payments

		This Claim Amount [A]		Cumulative Claim Amount [B]
	Services	Indirect	Direct	
9	Total amount of Services costs claimed:	\$0.00	\$0.00	\$0.00
10	Subtotal amount eligible for Services Costs			\$0.00
11	Amount paid by the Iowa DOT for Services prior to this claim:			\$0.00
12	Subtotal amount due this payment/final payment for Services:			\$0.00
13	Amount due for Reimbursement, Direct Vendor Payments and Services			\$0.00

CERTIFICATION

I hereby certify that all eligible project activities for which reimbursement and direct vendor payment is requested have been completed in compliance with the project plans, specifications, project agreement, the laws of the State of Iowa and the ordinances of the CITY/COUNTY or Local Public Agency, that the items claimed for payment are proper and true and that no part of this claim has been paid by the Iowa DOT.

 Recipient Representative (Computer Entry or Printed)

 Signature Date (Computer Entry or Printed)

 Recipient Representative Signature (Sign in Ink)

 Recipient Representative Title (Computer Entry or Printed)

Make Check Payable to:

 Grant Recipient or Designated Vendor (Computer Entry or Printed)

 Mailing Address (Computer Entry or Printed)

Submit an electronic version of this form and required documentation via email to lrf.support@iowadot.us for review. Upon approval, mail signed original and required documentation to: LRTF Program Coordinator, Office of Design, Iowa Department of Transportation, 800 Lincoln Way, Ames, Iowa 50010.

FOR INTERNAL USE ONLY	INITIALS	DATE
IDOT Approval		
IDOT Approval		

JASPER COUNTY ENGINEER'S OFFICE

910 N 11th Ave E
Newton, Iowa 50208

(641) 792-5862
FAX – (641) 791-7740



Michael J. Frietsch, P.E, FMP
County Engineer
mfrietsch@jasperia.org

September 8, 2022

To: Jasper County Supervisors

From: Michael J. Frietsch, P.E., FMP
County Engineer

Re: Hydroseeder

Dear Supervisors,

The current hydroseeder is a 2004 Bowie 1100 and at the end of its useful life. This unit is no longer a reliable machine producing consistent results. Given the need for a new hydroseeder, quotes were requested for a new Bowie 1100 model and a new Finn Model T120. The Bowie 1100 was quoted at \$63,830 while the Finn Model T120 was quoted at \$87,795.

Given the longevity experienced with the current Bowie 1100 and the lower upfront cost for the new Bowie 1100 would be recommended. Further, we were successful in securing a Living Roadway Trust Fund Grant for Counties in the amount of \$24,000, so a total of \$39,830 will be required from the Secondary Roads Budget to complete the purchase. This purchase was included in the equipment portion of the Secondary Roads Budget for FY23. Therefore, we respectfully ask for approval of the quote from Bowie for a new 1100 model hydroseeder at a total cost of \$63,830.

Sincerely,

Michael J. Frietsch, P.E., FMP
County Engineer



CICS

Supporting Individuals. Strengthening Communities.

June 16, 2022

County Board of Supervisors,

As county staff performing duties for CICS transition to Franklin County employment, they will no longer be employees of their previous counties. Some staff will continue to perform ancillary duties for their counties such as processing eligibility for shelter care and substance abuse services.

We have reached out to administrative team members to identify which staff are performing which services for which counties. Part of the review has identified that CICS staff will be performing this service FOR your county. CICS would like to ensure compliance with HIPAA by having a Business Associate Agreement in place.

That Business Associate Agreement is attached showing what duties will be handled by CICS staff members. Please have this reviewed and approved by your board or your HIPAA Compliance officer according to the procedures you have in place.

On a side note, since we are doing the service for you, we are your Business Associate. As such, if you would prefer to use your own document you may do so.

If you have any questions about this, please feel free to reach out to me or the member of the administrative team that covers your county.

Thank you and thank you for your participation in CICS.

Russell Wood
CICS CEO

BUSINESS ASSOCIATE AGREEMENT

THIS BUSINESS ASSOCIATE AGREEMENT (“Agreement”) is entered into by and between Jasper County, Iowa (the “Covered Entity”), and Central Iowa Community Services (the “Business Associate”).

RECITALS

A. Covered Entity is a health care provider subject to the Health Insurance Portability and Accountability Act of 1996, the HITECH Act, and regulations promulgated thereunder (“HIPAA”).

B. Business Associate, through the provision of certain services for or on behalf of the Covered Entity pursuant to a certain agreement entered into with Covered Entity effective on 7/1/22 for the provision by Business Associate of substance use disorder client funding eligibility and claim processing. for Covered Entity (the “Services Agreement”), is a “business associate” of the Covered Entity as that term is defined in 45 C.F.R. § 160.103, and is subject to the Security Rule and certain provisions of the Privacy Rule.

C. Covered Entity is required by HIPAA to obtain satisfactory assurances that Business Associate will appropriately safeguard all PHI and Electronic PHI disclosed by, or created or received by Business Associate on behalf of, Covered Entity.

NOW, THEREFORE, in consideration of entering into the Services Agreement and the mutual promises and agreements below and in order to comply with all legal requirements, the parties agree as follows:

I. DEFINITIONS

1.1 “**Agreement**” has the meaning set forth in the preamble.

1.2 “**ARRA Breach**” has the same meaning as the term “Breach” in Section 13400(1) of the HITECH Act (i.e. 42 USCA 17921) and 45 CFR 164.402.

1.3 “**Business Associate**” has the meaning set forth in the preamble.

1.4 “**Covered Entity**” has the meaning set forth in the preamble.

1.5 “**Data Aggregation**” means the combining of PHI created or received under this Agreement with the PHI Business Associate receives or creates in its arrangement with another covered entity under the Privacy Rule to permit data analysis that relate to the Health Care Operations of the covered entities.

1.6 “**Designated Record Set**” means a group of records maintained by or for the Covered Entity that is: (i) the medical records and billing records about Individuals; (ii) the enrollment, payment, claims adjudication, and case or medical management record systems maintained by or for a health plan; or (iii) used, in whole or in part, by or for the Covered Entity to make decisions about Individuals. As used herein the term “record” means any item, collection,

or grouping of information that includes PHI and is maintained, collected, used or disseminated by or for the Covered Entity.

1.7 “**Document Demand**” has the meaning set forth in Section 3.13.

1.8 “**Effective Date**” has the meaning set forth in the preamble.

1.9 “**Electronic PHI**” means information that comes within paragraphs 1(i) or 1(ii) of the definition of “PHI,” as defined in 45 C.F.R. § 160.103, limited to the information created, received, maintained or transmitted by Business Associate on behalf of Covered Entity.

1.10 “**HIPAA**” has the meaning set forth in the Recitals.

1.11 “**HITECH Act**” means Title XIII and Title IV of Division B of the American Recovery and Reinvestment Act of 2009, Public Law No. 111-5 and all regulations promulgated thereunder.

1.12 “**Individual**” means the person who is the subject of the PHI and includes a person who qualifies as a personal representative in accordance with 45 C.F.R. § 164.502(g).

1.13 “**PHI**” means Protected Health Information that is provided by Covered Entity to Business Associate or created or received by Business Associate on behalf of Covered Entity.

1.14 “**Privacy Rule**” means the Standards for Privacy of Individually Identifiable Health Information at 45 C.F.R. part 160 and part 164, subparts A and E.

1.15 “**Protected Health Information**” (or “PHI”) means any information, whether transmitted or maintained in electronic, written, oral, or any other form or medium, that relates to the past, present, or future physical or mental health or condition of an Individual; the provision of health care to an Individual; or the past, present or future payment for the provision of health care to an Individual; and (i) identifies the Individual, or (ii) with respect to which there is a reasonable basis to believe the information can be used to identify the Individual.

1.16 “**Required by Law**” has the same meaning as the term ““required by law” in 45 C.F.R. § 164.103.

1.17 “**Secretary**” means the Secretary of the U.S. Department of Health and Human Services or his or her designee.

1.18 “**Security Incident**” has the same meaning as the term “security incident” in 45 C.F.R. § 164.304.

1.19 “**Security Rule**” means the Security Standards and Implementation Specifications at 45 C.F.R. part 160 and part 164, subpart C.

1.20 “**Services Agreement**” has the meaning set forth in the Recitals.

1.21 “Unsecured PHI” or “Unsecured PHI” means PHI that is not secured through the use of a technology or methodology that the Secretary specifies in guidance renders PHI unusable, unreadable, or indecipherable to unauthorized Individuals, such as the guidance set forth in 74 Fed. Reg. 19006 (April 27, 2009) and updated in 74 Fed. Reg. 42740 (August 24, 2009).

1.22 Remaining Terms. Capitalized terms used, but not otherwise defined, in this Agreement have the meaning ascribed to them in HIPAA, the Privacy Rule, the Security Rule or the HITECH Act.

II. PERMITTED USES AND DISCLOSURES OF PHI

2.1 Services Agreement Uses and Disclosures. Business Associate may use or disclose PHI for purposes of performing its obligations and functions under the Services Agreement, provided that such use or disclosure would not violate the Privacy Rule if done by Covered Entity.

2.2 Other Permitted Uses. If necessary, Business Associate may use PHI: (i) for the proper management and administration of the Business Associate; (ii) to carry out the legal responsibilities of the Business Associate; and (iii) for the provision of Data Aggregation services relating to the Health Care Operations of Covered Entity.

2.3 Other Permitted Disclosures. If necessary, Business Associate may disclose PHI for the purposes described in Section 2.2 above if: (i) the disclosure is Required by Law; or (ii) Business Associate obtains reasonable written assurance from the person or entity to whom it discloses the PHI that the PHI will remain confidential and will be used or further disclosed only as Required by Law or for the purpose for which it was disclosed to the person or entity, and the person or entity notifies Business Associate of any instances of which it is aware in which the confidentiality of the PHI has been breached.

III. OBLIGATIONS OF BUSINESS ASSOCIATE

3.1 Compliance with Privacy Rule. Business Associate shall comply with all applicable provisions of the Privacy Rule in carrying out its obligations under the Services Agreement and this Agreement. Further, to the extent Business Associate is to carry out any of Covered Entity’s obligations under subpart E of 45 CFR 164, Business Associate agrees to comply with the requirements of such subpart that apply to Covered Entity in the performance of such obligations.

3.2 Prohibition on Unauthorized Use or Disclosure. Business Associate shall not use or disclose PHI except as permitted by this Agreement or as Required by Law.

3.3 Minimum Necessary.

3.3.1 Business Associate shall limit its use and disclosure of PHI under this Agreement to the “minimum necessary,” as set forth in guidance that the Secretary will issue regarding what constitutes “minimum necessary” under the Privacy Rule. Until the issuance of such guidance, Business Associate shall limit its use and disclosure of PHI, to the extent practicable, to the Limited Data Set (as that term is defined in 45 C.F.R.

§ 164.514(e)(2)), or, if needed, to the minimum necessary to accomplish the Business Associate's intended purpose. Business Associate may in good faith determine what constitutes the minimum necessary to accomplish the intended purpose of any disclosure of PHI.

3.3.2 Paragraph (a) above does not apply to: (1) disclosures to or requests by a health care provider for treatment; (2) uses or disclosures made to the Individual; (3) disclosures made pursuant to an authorization as set forth in 45 C.F.R. § 164.508; (4) disclosures made to the Secretary under 45 C.F.R. part 160, subpart C; (5) uses or disclosures that are Required by Law as described in 45 C.F.R. § 164.512(a); and (6) uses or disclosures that are required for compliance with applicable requirements of the Privacy Rule.

3.4 Safeguarding PHI; Security Regulations. Business Associate shall use appropriate administrative, physical, and technical safeguards and comply with the Security Rule with respect to Electronic PHI to prevent the use or disclosure of PHI other than as provided for by this Agreement.

3.5 Mitigation. Business Associate shall mitigate, to the extent practicable, any harmful effect that is known to Business Associate of a Security Incident or a use or disclosure of PHI by Business Associate in violation of this Agreement.

3.6 Reporting. In the event that Business Associate becomes aware of a use or disclosure of PHI by Business Associate that is not permitted under this Agreement, Business Associate shall report such use or disclosure to the Covered Entity promptly in writing and in any event, within 5 days of becoming aware of the use or disclosure. Business Associate agrees to report to Covered Entity in writing any Security Incident of which it becomes aware, except that, for purposes of this reporting requirement the term "Security Incident" does not include inconsequential incidents that occur on a frequent basis such as scans or "pings" that are not allowed past Business Associate's firewall. Notwithstanding this Section 3.7, the Business Associate's reporting obligations regarding any ARRA Breach are set forth in Article IV.

3.7 Subcontractors. Business Associate shall ensure that all subcontractors or agents of Business Associate that create, receive, maintain or transmit PHI on behalf of the Business Associate agree in writing to the same restrictions and conditions that apply through this Agreement to Business Associate with respect to such information. Business Associate shall ensure that all agents, including subcontractors, to whom it provides Electronic PHI, agree in writing to implement reasonable and appropriate safeguards to protect such Electronic PHI.

3.8 Access.

3.8.1 Within twenty (20) days of a request from Covered Entity, Business Associate shall furnish the PHI contained in a Designated Record Set that will enable the Covered Entity to respond to an Individual's request for inspection or copies of PHI about the Individual pursuant to 45 CFR § 164.524.

3.8.2 In the event an Individual requests access to PHI directly from Business Associate, Business Associate shall forward such request to the Covered Entity

immediately and take no direct immediate action on any such request. If the Covered Entity determines that an Individual is to be granted access to PHI, then Business Associate shall cooperate with the Covered Entity to provide to any Individual, at the Covered Entity's direction, any PHI requested by such Individual.

3.9 Amendment.

3.9.1 If the Covered Entity requests that Business Associate amend any Individual's PHI or a record regarding an Individual contained in a Designated Record Set, then Business Associate shall provide the relevant PHI to the Covered Entity for amendment and incorporate any such amendments in the PHI as required by 45 C.F.R. §164.526.

3.9.2 In the event an Individual requests directly to Business Associate that PHI be amended, Business Associate shall forward such request to the Covered Entity within ten (10) days of Business Associate's receipt of such request and shall take no direct immediate action on the request.

3.10 Records Availability. Business Associate shall make its internal practices, books and records relating to the use and disclosure of PHI available to the Secretary for purposes of determining compliance with the Privacy Rule and the Security Rule.

3.11 Accounting of Disclosures.

3.11.1 If the Covered Entity requests that Business Associate furnish an accounting of disclosures of PHI made by Business Associate regarding an Individual during the six (6) years prior to the date on which the accounting was requested, then Business Associate shall, within fifteen (15) days of such request, make available to the Covered Entity such information as is in Business Associate's possession and is required for the Covered Entity to make the accounting required by 45 C.F.R. §164.528 and future regulations to be promulgated regarding accounting of disclosures.

3.11.2 In the event an Individual requests an accounting of disclosures directly from Business Associate, Business Associate shall within ten (10) days forward such request to the Covered Entity and shall take no direct action on the request.

3.12 Demands for Production of PHI.

3.12.1 Receipt by Business Associate. If Business Associate receives a subpoena, civil or administrative demand, or any other demand for production of PHI (a "Document Demand"), Business Associate shall provide a copy of such Document Demand to Covered Entity within five (5) days of receipt. To the extent the PHI that is the subject of the Document Demand is in the possession of Business Associate, and a response is warranted according to the standards contained in 45 C.F.R. § 164.512(e), Business Associate shall timely respond to the Document Demand.

3.12.2 Receipt by Covered Entity. If Covered Entity receives a Document Demand, Business Associate shall provide to Covered Entity any PHI responsive to such

Document Demand and assist and cooperate with Covered Entity in responding to such Document Demand in a timely manner and in accordance with the standards under 45 C.F.R. § 164.512(e).

3.13 Request for Restrictions on Disclosure of PHI. As required by Section 13405 of the HITECH Act and 45 CFR 164.522 (except as otherwise required by law), Business Associate shall comply with any request of an Individual for the Business Associate to restrict the disclosure of PHI of the Individual when the disclosure is to a health plan for purposes of carrying out payment or health care operations (and is not for purposes of carrying out treatment), and the PHI pertains solely to a health care item or service for which the health care provider involved has been paid out of pocket in full.

3.14 Remuneration for PHI.

3.14.1 Except as explicitly permitted in the Services Agreement and also set forth in paragraph (b) below, Business Associate shall not directly or indirectly receive remuneration in exchange for any PHI of an Individual unless the Individual provided to the Covered Entity a valid authorization in accordance with 45 C.F.R. § 164.508 that specifically authorizes the Business Associate to exchange the PHI for remuneration.

3.14.2 Paragraph (a) above does not apply if the purpose of the exchange is: (1) for public health purposes pursuant to 45 CFR § 164.512(b) or § 164.514(e); (2) for research purposes pursuant to 45 CFR § 164.512(i) or § 164.514(e), where the only remuneration received by the Covered Entity or Business Associate is a reasonable cost-based fee to cover the cost to prepare and transmit the PHI for such purposes; (3) for treatment and payment purposes pursuant to 45 CFR § 164.506(a); (4) for the sale, transfer, merger, or consolidation of all or part of the Covered Entity and for related due diligence as described in the HIPAA definition of health care operations and pursuant to 45 CFR § 164.506(a); (5) To or by a Business Associate for activities that the Business Associate undertakes on behalf of a Covered Entity (or on behalf of a Business Associate in the case of a subcontractor), pursuant to 45 CFR §§ 164.502(e) and 164.504(e), and the only remuneration provided is by the Covered Entity to the Business Associate (or by the Business Associate to the subcontractor, if applicable), for the performance of such activities; (6) to an Individual, when the Individual requests access to his or her PHI pursuant to 45 CFR § 164.524 or when the Individual requests an accounting of disclosures pursuant to 45 CFR § 164.528; (7) for disclosures Required By Law; and (8) for any other purpose permitted by HIPAA where the only remuneration received by the Covered Entity or Business Associate is a reasonable, cost-based fee to cover the cost to prepare and transmit the PHI for such purpose or a fee expressly permitted by law.

3.15 Marketing Restrictions. Business associate shall ensure that any Marketing communications it makes on behalf of Covered Entity are in compliance with the rules governing marketing set forth in 45 C.F.R. 164.508(a)(3), including but not limited to the requirements that Business Associate must obtain an authorization from an Individual prior to making any marketing communication to such Individual.

3.16 Fundraising Limitations. Business Associate shall ensure that any fundraising communications Business Associate makes on behalf of the Covered Entity are in compliance with the rules governing fundraising communications set forth in 45 C.F.R. 164.514(f), including but not limited to the requirement that Business Associate must provide, with each fundraising communication made to an Individual, a clear and conspicuous opportunity for the recipient of the communication to elect not to receive any further fundraising communications. Business Associate shall ensure that all Individuals electing not to receive any further fundraising communications do not receive any further fundraising communications.

IV. ARRA BREACH NOTIFICATION.

4.1 Risk Assessment by Business Associate. If Business Associate becomes aware of a potential ARRA Breach, Business Associate shall complete a risk assessment of the potential ARRA Breach to determine whether the potential ARRA Breach is an ARRA Breach. Such risk assessment shall include at least all the factors identified in 45 CFR 164.402(2), as amended by the final rule published in the Federal Register on January 25, 2013 at 78 Fed. Reg. 5566.

4.2 Notification to Covered Entity. If, after completing such risk assessment, Business Associate concludes that there was an ARRA Breach, Business Associate shall notify the Covered Entity of the ARRA Breach as soon as reasonably possible, and in all cases within five (5) business days of the first day on which any employee, officer or agent of Business Associate either knows or by exercising reasonable diligence would have known that an ARRA Breach occurred. The notification to Covered Entity shall include, if known, the identification of each Individual whose Unsecured PHI has been, or is reasonably believed by Business Associate to have been, accessed, acquired, used or disclosed during such ARRA Breach. The notification shall also include: (a) a brief description of what happened, including the date of the ARRA Breach and the date of the discovery of the ARRA Breach, if known; (b) a description of the types of Unsecured PHI that were involved in the ARRA Breach (such as whether the full name, social security number, date of birth, home address, account number, diagnosis disability code or other types of information were involved); (c) recommended steps that Individuals should take to protect themselves from potential harm resulting from the ARRA Breach; and (d) a brief description of what the Business Associate is doing to investigate the ARRA Breach, to mitigate harm to Individuals, and to protect against any further ARRA Breaches. Business Associate shall maintain evidence to demonstrate that any required risk assessment was completed and notification to the Covered Entity under this paragraph was made unless the Business Associate determines that a delayed notice (as described in Section 4.3) applies.

4.3 Delayed Notification to Covered Entity. Notwithstanding Section 4.2 above, if a law enforcement official states in writing to Business Associate that the notification to Covered Entity required under Section 4.2 would impede a criminal investigation or cause damage to national security, then Business Associate may delay the notification for any period of time set forth in the written statement of the law enforcement official. If the law enforcement official provides an oral statement, then Business Associate shall document the statement in writing, including the name of the law enforcement official making the statement, and may delay the notification required under Section 4.2 for no longer than thirty (30) days from the date of the oral statement, unless the law enforcement official provides a written statement during that time that specifies a different time period. Business Associate shall be obligated to maintain evidence to

demonstrate the reason for the delayed notification and that the required notification under this paragraph was made

4.4 Notification to Individuals, the Secretary and/or the Media. In the event of an ARRA Breach caused by Business Associate, its agents and/or subcontractors, Business Associate shall provide assistance to Covered Entity in making all ARRA Breach notifications. To the extent Covered Entity incurs expenses and costs to comply with its notification obligations with respect to an ARRA Breach by Business Associate, its agents and/or subcontractors, in addition to any other remedies that may be available to Covered Entity under this Agreement or any applicable law, Business Associate shall reimburse Covered Entity for all costs and expenses (including attorneys' fees) incurred by Covered Entity related to providing the notifications required under 45 C.F.R. §§ 164.404, 406 and 408. Notwithstanding the foregoing, if the parties agree that Business Associate will, on behalf of Covered Entity, and within the applicable time frames required by law under 45 C.F.R. §§ 164.404, 406 and 408, prepare and send out any and all required ARRA Breach notifications to Individuals, the Secretary and/or to the media, Business Associate shall prepare and send such ARRA Breach notifications at Business Associate's sole expense and in compliance with the requirements of 45 C.F.R. 164.404, 406 and 408, as applicable. However, any ARRA Breach notifications Business Associate would prepare and send on behalf of Covered Entity shall be subject to Covered Entity's review and pre-approval before the notifications are sent. Additionally, in the event of an ARRA Breach, Business Associate agrees to pay for the credit monitoring fees for affected Individuals for a period of at least two (2) years of credit monitoring.

V. TERM AND TERMINATION

5.1 Term. This Agreement is effective upon the effective date of the Services Agreement, and except for the rights and obligations set forth in this Agreement specifically surviving termination, shall terminate the later of the date the Services Agreement terminates or when all PHI is returned to Covered Entity or, with prior permission of Covered Entity, destroyed.

5.2 Termination for Cause. Notwithstanding any provision in this Agreement, Covered Entity may terminate this Agreement and the Services Agreement if Covered Entity determines, in its sole discretion, Business Associate has breached any provision of this Agreement or otherwise violated HIPAA, the Privacy Rule, the Security Rule or the HITECH Act. Covered Entity shall provide written notice to Business Associate with an opportunity for Business Associate to cure the breach or end the violation within ten (10) business days of such written notice, unless cure is not possible. If Business Associate fails to cure the breach or end the violation within the specified time period, or if cure is not possible, this Agreement and the Service Agreement shall automatically and immediately terminate, unless termination is infeasible.

5.3 Termination after Repeated Violations. Notwithstanding any provision in the Agreement, Covered Entity may terminate the Services Agreement and this Agreement if Covered Entity determines, in its sole discretion, that Business Associate has repeatedly breached any provision of this Agreement or otherwise violated HIPAA, the Privacy Rule, the Security Rule or the HITECH Act, irrespective of whether, or how promptly, Business Associate may remedy such violation after being notified of the same.

5.4 Obligations Upon Termination. Business Associate's obligations to protect the privacy and security of PHI shall be continuous and shall survive termination, cancellation, expiration or other conclusion of this Agreement or the Services Agreement. Upon termination of this Agreement, Business Associate will forward to Covered Entity, or to Covered Entity's designee, the records necessary for continued administration of Covered Entity as directed by Covered Entity. After the forwarding of said records, whatever PHI remains with Business Associate will be subject to the following:

5.4.1 Except as provided in paragraph (b) of this Section 5.4, upon termination, cancellation, expiration or other conclusion of this Agreement, for any reason, Business Associate shall return or, if Covered Entity gives written permission, destroy, PHI in whatever form or medium and retain no copies of such PHI. Business Associate will complete such return or destruction as soon as possible, but in no event later than sixty (60) days from the date of the termination of this Agreement. Within ten (10) days of the return or destruction of all PHI by Business Associate, Business Associate shall provide written certification to Covered Entity that the return or destruction of PHI has been completed.

5.4.2 In the event that Business Associate determines that returning or destroying the PHI is infeasible, Business Associate shall provide to Covered Entity notification of the conditions that make return or destruction infeasible. Upon mutual agreement of the parties that return or destruction of PHI is infeasible, Business Associate shall extend the protections of this Agreement to such PHI and limit further uses and disclosures of such PHI to those purposes that make the return or destruction infeasible, for so long as Business Associate maintains such PHI.

VI. INDEMNIFICATION; INSURANCE

6.1 Indemnification by Business Associate. Business Associate will indemnify and hold harmless Covered Entity, and any affiliate, officer, director, employee or agent of Covered Entity from and against any claim, cause of action, liability, damage, cost or expense, including attorneys' fees and court or proceeding costs, arising out of or in connection with any use or disclosure of PHI that violates or is not permitted by this Agreement, HIPAA, the Privacy Rule, the Security Rule or the HITECH Act, or other breach of this Agreement by Business Associate or any subcontractor or agent of Business Associate.

6.2 Right to Tender or Undertake Defense. If Covered Entity is named as a party in any judicial, administrative or other proceeding arising out of or in connection with any non-permitted or violating use or disclosure of PHI or other breach of this Agreement by Business Associate or any subcontractor or agent of Business Associate, Covered Entity shall have the option at any time either to: (i) tender its defense to Business Associate, in which case Business Associate will provide qualified attorneys, consultants, and other appropriate professionals to represent Covered Entity's interests at Business Associate's expense; or (ii) undertake its own defense, choosing the attorneys, consultants, and other appropriate professionals to represent its interests, in which case Business Associate will be responsible for and pay the reasonable fees and expenses of such attorneys, consultants, and other professionals.

6.3 Right to Control Resolution. Covered Entity has the sole right and discretion to settle, compromise or otherwise resolve any and all claims, causes of actions, liabilities or damages against it, notwithstanding that Covered Entity may have tendered its defense to Business Associate. Any such resolution will not relieve Business Associate of its obligation to indemnify Covered Entity under this Agreement.

6.4 Insurance. Upon request, Business Associate shall obtain and maintain insurance coverage against improper uses and disclosures of PHI by Business Associate, naming Covered Entity as an additional named insured. Upon request, Business Associate shall provide a certificate evidencing such insurance coverage.

6.5 Conflicts. With respect to any breaches or violations of this Agreement, the provisions in this Section 6 supersede any inconsistent terms contained in the Services Agreement.

VII. GENERAL PROVISIONS

7.1 Effect. The terms and provisions of this Agreement supersede any other conflicting or inconsistent terms and provisions in any agreements between the parties, including all exhibits or other attachments thereto and all documents incorporated therein by reference.

7.2 Amendment. Business Associate and the Covered Entity agree to amend this Agreement to the extent necessary to allow either party to comply with HIPAA, the Privacy Rule, the Security Rule, or the HITECH Act. All such amendments shall be made in a writing signed by both parties.

7.3 No Third Party Beneficiaries. This Agreement is intended for the benefit of Business Associate and Covered Entity only. Nothing express or implied is intended to confer or create, nor be interpreted to confer or create, any rights, remedies, obligations or liabilities to or for any third party beneficiary, including without limitation Individuals who are the subject of PHI.

7.4 Severability. In the event that any provision of this Agreement violates any applicable statute, ordinance, or rule of law in any jurisdiction that governs this Agreement, such provision shall be ineffective to the extent of such violation without invalidating any other provision of this Agreement.

7.5 No Waiver. No provision of this Agreement may be waived except by an agreement in writing signed by the waiving party. A waiver of any term or provision shall not be construed as a waiver of any other term or provision.

7.6 Assignment. This Agreement may not be assigned by either party without the prior written consent of the other party; provided, however, that the parties shall cooperate to assign this Agreement as appropriate if the Services Agreement is assigned.

7.7 Relationship of the Parties. Business Associate and Covered Entity are independent contractors and all acts performed by Business Associate are performed solely in its capacity as an independent contractor.

7.8 Counterparts; Facsimile Signature. This Agreement may be executed by facsimile and/or in counterparts, each of which shall be an original and all of which together shall constitute one and the same binding instrument.

7.9 Notification

7.9.1 Business Associate. To the extent notice is required to be provided by Covered Entity to Business Associate under any provision in this Agreement, notice shall be provided to:

Russell Wood
russell.wood@cicsmhds.org
126 S. Kellogg Ave., Ste. 001
Ames, IA 50010
Phone 515-663-2928

7.9.2 Covered Entity. To the extent notice is required to be provided by Business Associate to Covered Entity under any provision in this Agreement, notice shall be provided to:

Dennis Simon, HR Director
101 First Street, N
Newton, IA 50208
Fax# 641-787-1101

7.10 Interpretation. Any ambiguity in this Agreement shall be resolved in favor of a meaning that permits Covered Entity to comply with HIPAA, the Privacy Rule, the Security Rule, and the HITECH Act.

INTENDING TO BE LEGALLY BOUND, the parties hereto have caused this Agreement to be executed by their duly authorized representatives.

BUSINESS ASSOCIATE

Central Iowa Community Services

By: _____

Print Name: _____

Title: _____

Date: _____

COVERED ENTITY

Jasper County, Iowa

By: _____

Print Name: _____

Title: _____

Date: _____

Attest: _____
Dennis K Parrott - Auditor

Date: _____

Tuesday, September 6, 2022, the Jasper County Board of Supervisors met in regular session at 9:30 a.m. Supervisors Talsma, Carpenter, and Cupples present and accounted for; Chairman Talsma presiding.

Motion by Cupples and seconded by Carpenter to approve a contract for services between Jasper County and MercyOne Newton Medical Center Laboratory for testing service for the employee blood draw.

YEA: CARPENTER, CUPPLES, TALSMA

Building and Grounds Director, Adam Sparks, presented two quotes for a Polaris Sportsman 570 EPS and Plow System and they are as follows: VanWall \$10,880 and Hicklin Power Sports LLC \$11,460.29.

Motion by Cupples and seconded by Carpenter to approve the purchase of a Polaris Sportsman 570 EPS and Plow System from VanWall in the amount of \$10,880.

YEA: CARPENTER, CUPPLES, TALSMA

Motion by Cupples and seconded by Carpenter to approve the Officer Training Liability Agreement in the amount of \$9,030 between Jasper County and Leon Spataru.

YEA: CARPENTER, CUPPLES, TALSMA

Motion by Cupples and seconded by Carpenter to set Public Hearing dates for the rezoning request made by Gregory Meckley on part of the West half of NW ¼ Section 5 Township 81 North, Range 19 in Jasper County from Agricultural to General Industrial, for September 20th, 27th and October 4, 2022, at 9:30 a.m. in the Board of Supervisors Room of the Jasper County Courthouse.

YEA: CARPENTER, CUPPLES, TALSMA

Motion by Cupples and seconded by Carpenter to adopt Resolution 22-72 to approve the Der Eichenwald Subdivision in a portion of the N ½ of the SE ¼ of Section 13, Township 80 North, Range 17 West in Jasper County, Iowa.

YEA: CARPENTER, CUPPLES, TALSMA

A complete copy of the Resolution is on file in the Office of the Jasper County Auditor.

Motion by Cupples and seconded by Carpenter to approve the Civil Service Commission Certification List.

YEA: CARPENTER, CUPPLES, TALSMA

Motion by Cupples and seconded by Carpenter to approve a Permanent Construction Easement between Jasper County and Duane & Marcia Bruxvoort in the amount of \$8,000 in part of the NW ¼ of the NW ¼ of Section 11, Township 79 North, Range 21 West, in Jasper County, Iowa, Parcel No. 11.11.100.002.

YEA: CARPENTER, CUPPLES, TALSMA

Motion by Cupples and seconded by Carpenter to approve a Temporary Construction Easement between Jasper County and Duane & Marcia Bruxvoort in the amount of \$6 in part of the NW ¼ of the NW ¼ of Section 11, Township 79 North, Range 21 West, in Jasper County, Iowa, Parcel No. 11.11.100.002.

YEA: CARPENTER, CUPPLES, TALSMA

Motion by Cupples and seconded by Carpenter to approve a Memorandum of Understanding between Jasper County and Duane & Marcia Bruxvoort concerning the installation and future maintenance of a culvert.

YEA: CARPENTER, CUPPLES, TALSMA

Motion by Cupples and seconded by Carpenter to approve a Temporary Construction Easement for Public Highway in the amount of \$6 between Jasper County and Country View Investments LLC for that part of Parcel "B" in the SW ¼ of the SW ¼ of Section 2, Township 79 North, Range 21 West in Jasper County, Iowa, Parcel No. 11.02.300.011.

YEA: CARPENTER, CUPPLES, TALSMA

Motion by Cupples and seconded by Carpenter to table agenda item 6(e) Purchase of Temporary Easement for Public Highway on Parcel No. 11.11.100.001 for two weeks, until September 20, 2022.

YEA: CARPENTER, CUPPLES, TALSMA

Motion by Cupples and seconded by Carpenter to adopt Resolution 22-73 to approve the Vacation of a Portion of Jasper County Public Roadway in that portion of W 140th Street North in Sections 29 & 30, Township 81 North, Range 21 West, Jasper County, Iowa.

YEA: CARPENTER, CUPPLES, TALSMA

A complete copy of the Resolution is on file in the Office of the Jasper County Auditor.

Motion by Cupples and seconded by Carpenter to approve an agreement between Calhoun-Burns and Associates, Inc for Professional Structural Engineering Services for a bridge located near the center of Section 3, Township 80 North, Range 21 West on the Corporate Line in the City of Mingo in the amount of \$17,000.

YEA: CARPENTER, CUPPLES, TALSMA

Motion by Cupples and seconded by Carpenter to approve a liquor license for Fore Seasons Golf Bar.

YEA: CARPENTER, CUPPLES, TALSMA

Motion by Carpenter and seconded by Cupples to approve claims paid through September 6, 2022.

YEA: CUPPLES, CARPENTER, TALSMA

Motion by Carpenter and seconded by Cupples to approve Board of Supervisors Minutes for August 23, 2022.

YEA: CUPPLES, CARPENTER, TALSMA

Motion by Carpenter and seconded by Cupples to adjourn the Tuesday, September 6, 2022, meeting of the Jasper County Board of Supervisors.

YEA: CUPPLES, CARPENTER, TALSMA

Dennis K. Parrott, Auditor

Brandon Talsma, Chairman

September 6, 2022

Tuesday, September 6, 2022, the Jasper County Board of Supervisors held a work session with Mike Frietsch, the County Engineer, to discuss the Granular Road Assessment & Maintenance Strategy. Supervisors Talsma, Carpenter, and Cupples were all present.

The Supervisors and the Engineer talked about four options to improving and maintaining the County roads system: Stabilization, Reclamation, Resurfacing and Spot Rocking and the potential costs to do each.

For Stabilization, Reclamation and Resurfacing there would be territories and schedules and for spot rock, the blade operators would determine when and where rock was needed.

The plan is based on need, using things like traffic counts and road conditions, work to be done. Not everyone will necessarily get their road worked on as in the past when gravel was blanketed on all roads in a particular section of the county on a rotating basis.

The Engineer gave the Board financial estimates for year one ranging from a total cost of \$3,898,000 to \$4,518,000.

It was recognized that over time the plan would need to be modified.

The Engineer stated that the next step would be to develop plans for paved routes.

The Board expressed an interest in having another work session about this topic in a couple of weeks.

Dennis K. Parrott, Auditor

Brandon Talsma, Chairman