



Jasper County, Iowa Board of Supervisors

PO Box 944, Newton, IA Phone: 641-792-7016 Fax: 641-792-1053

Denny Stevenson

Doug Cupples

Brandon Talsma

January 24, 2023

9:30 a.m.

www.jasperia.org

Live Stream: <https://jasper.zoom.us/j/97712718501>

Meeting ID: 977 1271 8501

Dial In: +1-312-626-6799

-Anyone that has an item on the agenda must appear in person for the Board to consider it.-

Pledge of Allegiance



Item 1 Sheriff – John Halferty

- a) Consider Approving the Purchase of an Ambulance for the Enhanced ALS Program
- b) Quotes for a New Copier at the Jail

Item 2 Engineer – Mike Frietsch

- a) Proposal to Update the 2005 Jasper County Geodetic Control Network
- b) Award of Contract to Herberger Construction Co for Project BRS-C050(116)—60-50

Item 3 Approval of Board of Supervisors Minutes for January 17, 2023

Item 4 Board Appointments

PUBLIC INPUT & COMMENTS



"Specializing in Emergency Vehicles"

January 9, 2023

Jasper County
2300 Law Center Drive
Newton, IA 50208

Arrow Manufacturing Inc. hereby proposes to furnish to you, subject to your acceptance of this proposal the following vehicle and equipment in accordance with the attachments hereto:

\$279,900	2022 Ram 5500 4x4 Heavy Duty Ambulance with a 6.7L Diesel Engine. Equipped with options as described and shown in website listing #86686. Includes all applicable
\$3,100	Supply and Install heavy duty front bumper with grill guard (black powder coat finish)
\$7,400	Custom printed vinyl graphics package with reflective chevron on rear including doors
\$876	Convert cabinet under rear counter to pull-out drawer & install power for IV warmer
\$575	Install IV warmer
\$667	Remove divider in L2 compartment, fabricate and install full-length adjustable shelf and add 110v outlet
\$1,843	Option- Supply and install a Howler/Rumbler siren
\$1,960	Option- Supply and install Buell air horn system
\$4,483	Supply new Stryker Stair Chair with foot rest option
\$27,858	Supply and Install New Stryker Power Load
<u>\$24,676</u>	New Stryker Power Pro XT Power Cot with high configuration options
\$354,338	TOTAL

FOB: Rock Rapids, IA

Approximate Completion: **Ambulance available immediately; 6-8 weeks for additions and install.**
Completion is dependent on parts availability and any changes made by customer after receipt of order.
Ambulance quoted currently available, but subject to prior sale.

Terms: (40%) deposit with receipt of signed proposal. Balance due upon pick up. Payment required no more than 30 days after notice of final completion.

Arrow Manufacturing Inc. reserves the right to withdraw or amend this proposal if not accepted by **January 31, 2023. Please sign and fax/email back as your acceptance of this proposal.**

Respectfully Submitted by:
ARROW MFG. INC.

Agreed and Accepted by:
JASPER COUNTY

(signature)

(signature/title)

(proposal date)

(acceptance date)

Attest: _____
Jenna Jennings, Auditor

801 South East Street ~ P.O. Box 349
Rock Rapids, IA 51246
1-800-743-3157
FAX 712-472-3156
www.arrowmfginc.com ~ info@arrowmfginc.com



arrowambulances.com/listing/86686

Arrow Ambulances
800.743.3157
info@arrowmfginc.com
801 South East Street
Rock Rapids, IA 51246



Image Coming Soon

2022 Ram 5500 4x4 Heavy Duty Arrow Ambulance

\$279,900

IN PRODUCTION

86686

New

N/A

4x4

6.7L Cummins Turbo Diesel

Ram 5500



Measurements

- Overall Length - 26
- Modular Length - 172
- Interior Height - 74
- Overall Height - 9'6"
- Modular Width - 96

Chassis Features

- Black & Gray Interior Colors
- 6-Speed Automatic Transmission
- 6.7L Cummins Turbo Diesel Engine
- Manual Shift-On-The-Fly 4x4

- Push-Button Start
- Integrated Voice Command with Bluetooth
- Liquid Ride Suspension System
- 52 Gallon Fuel Tank
- Smart Diesel Exhaust Brake
- Cruise Control
- Chrome Tubular Side Steps
- Sentry Key Theft Deterrent System
- Black Vinyl Floor
- SLT Luxury Package

Module Features

- Gen2 Remounted and Reconditioned WalkThru Ambulance
- Six Exterior Compartments
- Extruded Aluminum Compartment Doors
- Modular Gen2 Extruded Aluminum Body
- ALS Compartment with Inside/Outside Access to Jump Bags, etc.
- Step Up Side Entry
- Power Module Entry Door Locks
- Curbside Backboard Compartment with Stair Chair Storage
- Universal Oxygen Straps

Exterior Electrical

- Whelen M-Series Series LED Warning Light Package
- Whelen M-Series LED Warning Lights (5) on Front of Body
- Whelen M-Series M6 (6) Above Rear Doors
- Whelen LED Brake/Turn & LED Back-Up Assemblies
- Whelen ION LED Intersection Warning Lights on Front Fenders
- LED Marker Lights
- Whelen Siren Head- 2 / 100 Watt Speakers
- Whelen M-Series LED Scene Lights
- Whelen M-Series LED Warning (2) Each Side Upper Corners
- Whelen M-Series (2) On Rear at Window Level
- Whelen M-6 Amber LED Warning Light at Rear Center of Body
- Whelen ION LED Warning Lights in Grille
- Back-Up Camera
- 110-volt Shoreline w/ Auto-Eject & External Charging Indicator

Interior Electrical

- Solid State Electronic System with Circuit Breakers, Relays, Solenoids, etc.
- Electric O2 System with Digital Readout
- Whelen Interior LED Cot Lights
- Radio & Antenna Pre-wire installed
- Carling-Style Rocker Switches for Dependable, Quick, & No-Nonsense Functionality
- Driver's Switch Console with Back Lighting
- Check Out Lights Deactivated by Timer for Battery Preservation
- On-board Inverter/Charger with Shoreline Connection
- Intellitec Digital Clock
- Battery On and Module Disconnect Switches in Console
- Amp Meter, Voltmeter, Hour Meter, & Indicator of Lights for Door Ajar
- 110v and 12v Outlets in Front & Rear Action Areas
- USB Outlets in Cab & Module

Heat & A/C

- Digital Thermostat with Brushless HVAC Motor
- 3-way Heat/AC Control from Cab or Module
- User-Selectable Fan Speed Control w/ 7 Speeds

Outside Finish

- Aluminum Diamond Plate Trim Package
- Polished Aluminum Rub Rails
- Cast "Grabber" Door Stays on Rear Door
- PPG Certified Paint Process
- ADP Rock Guards
- Polished Fenderettes
- Heavy Duty Rear Bumper with ADP End Caps & Flip-Up Center Section for Ease of Cot Loading

Inside Finish

- Glove Box Holders Above Rear Doors and Above ALS Cabinet
 - Interior Flooring-Dark Gray Lonseal Lonplate II
 - Captain's Chair with Integrated Child Safety Seat and Swivel Base
 - Rear Action Area Counter
 - Locking ALS Lower
 - Suction
 - Stryker Universal Floor Track
 - Multiple O2 Outlets - Action Area Wall, Ceiling, Upper Squad Bench
 - Interior Plexiglass Cabinet Doors with Full-Length Extruded Aluminum Handles
 - Left Side Attendant (CPR) Seat
 - Inside/Outside Access to L3 Compartment with adjustable shelves
 - IV Hooks in Ceiling
 - Inside/Outside Access to Back Board Compartment
-



WARRANTY CERTIFICATE

The following are the Warranties offered by Arrow Manufacturing, Inc.

Lifetime emergency vehicle Structural and Conversion Warranty. Ambulance shall be free of substantial defects and shall include material and workmanship.

Lifetime Electrical System Conversion Warranty on Emergency Vehicle. Items not manufactured or installed by Arrow Manufacturing, Inc. shall be excluded and or otherwise covered under the warranty of the specific component Manufacturer.

PPG Ambulance Paint Conversion Warranty shall be five (5) years from the date of delivery. Paint warranty shall cover any painting done by Arrow Manufacturing on the modular body and on the chassis. Corrosion is not included.

One (1) Year General Warranty from Date of Pick Up/Delivery to the original retail purchaser to be free from defects in material and workmanship supplied or performed by Arrow Manufacturing under normal use and service. The following items are excluded by Arrow Manufacturing warranty:

- Chassis or items supplied by chassis manufacturer
- Tires, tire balancing, or wheel alignments
- General tightening, light bulbs or headlamp adjustments
- Separately manufactured items installed by Arrow including, but not limited to: batteries, sirens, battery chargers, inverters, lightbars and similar equipment. These are covered by warranties supplied by the manufacturer of the components. Arrow will facilitate the warranty and replacement of the defective component.
- Normal wear, abuse, accident, negligence or unapproved alteration of original parts.

Should repairs become necessary under the terms of this warranty, the extent of that repair shall be determined solely by Arrow Manufacturing and shall be authorized prior to any work performed.

Chassis Warranty shall be covered by the Chassis Manufacturer.

"Specializing in Emergency Vehicles"

801 South East Street ~ P.O. Box 349

Rock Rapids, IA 51246

1-800-743-3157

FAX 712-472-3156

www.arrowmfginc.com ~ info@arrowmfginc.com



TESS CORNERS VFD F-550 4 X 4 ULTRAMEDIC PASS-THROUGH

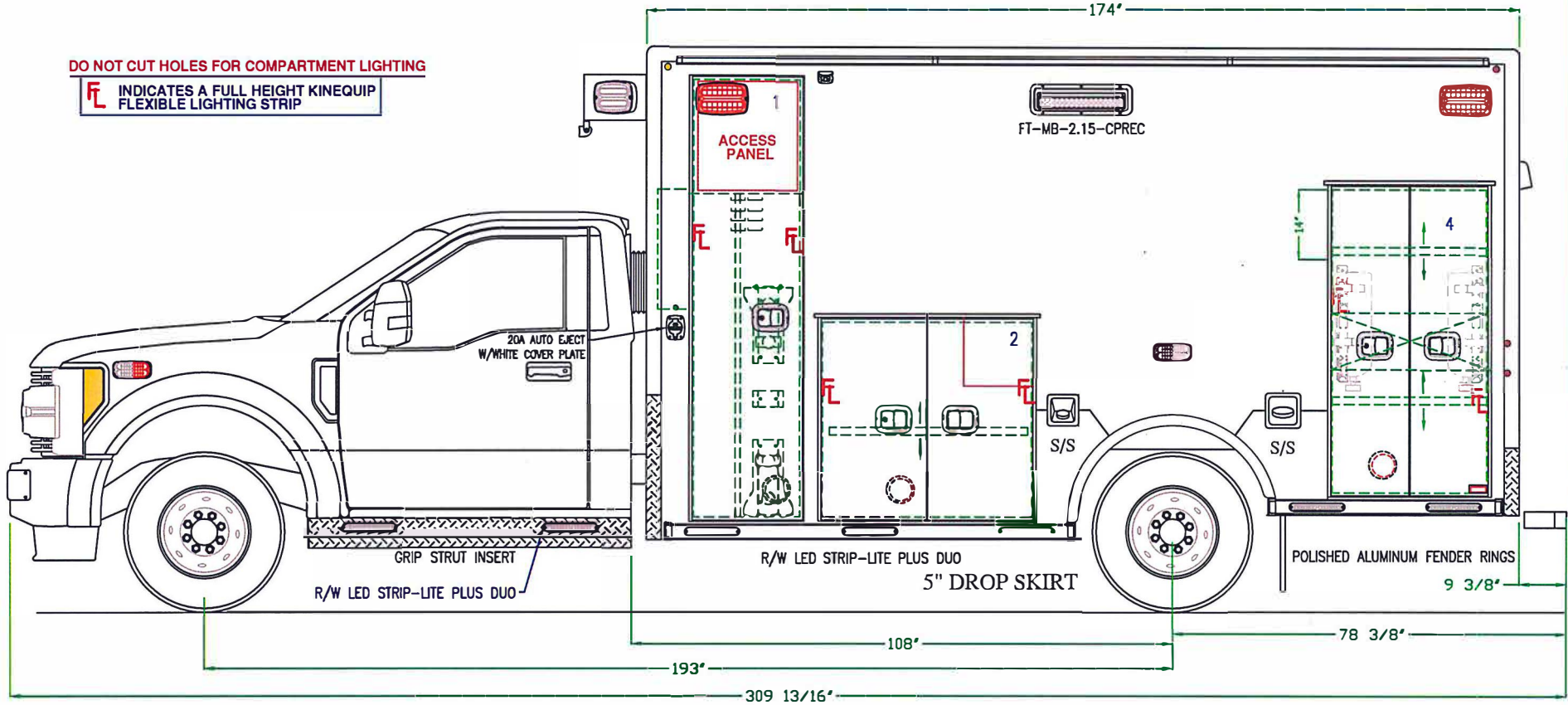

DOOR NO.	INTERIOR DIMENSIONS			NOTES
	HEIGHT	WIDTH	DEPTH	
1	88.50"	23.25"	22.00"	FIXED DIVDER, DOOR LOUVERS, O2 STORAGE
2	40.50"	43.88"	21.25"	(1) ADJ. SHELF
4	61.06"	32.50"	21.25"	(2) ADJ. SHELVES, SCBA STORAGE

NOTES:

DETAILS ARE CONCEPTUAL ONLY.
LAYOUT AND ALL DIMENSIONS ARE APPROXIMATE AND
SUBJECT TO MODIFICATION BY DESIGN ENGINEERING.

PROPRIETARY AND CONFIDENTIAL
THIS INFORMATION CONTAINED IN THIS DRAWING IS THE SOLE PROPERTY OF ROAD RESCUE ANY REPRODUCTION IN PART OR AS A WHOLE WITHOUT THE WRITTEN PERMISSION OF ROAD RESCUE IS PROHIBITED.

Road Rescue
2737 N. FORSYTH RD
WINTER PARK, FL 32792
www.roadrescue.com PHONE 800-932-7077 FAX 800-513-2688

STREETSIDE EXTERIOR DETAIL

BID NUMBER
18949

DRAWN BY GDG	DATE 09/12/2022	REVISION 1	REVISION 2	REVISION 3	SCALE	SHEET 1 OF 10
-----------------	--------------------	------------	------------	------------	-------	---------------



TESS CORNERS VFD F-550 4 X 4 ULTRAMEDIC PASS-THROUGH

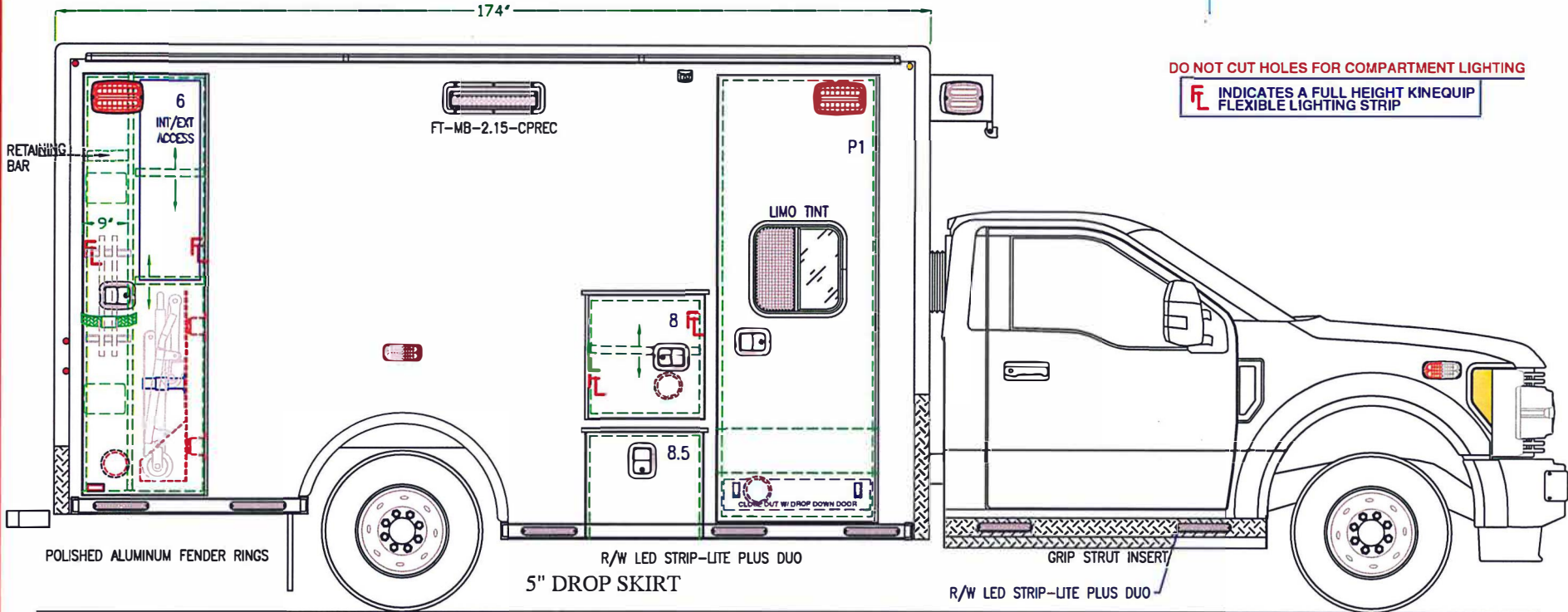

DOOR NO.	INTERIOR DIMENSIONS			NOTES	DOOR NO.	DOOR DIMENSIONS		MISC. NOTES
	HEIGHT	WIDTH	DEPTH			HEIGHT	WIDTH	
6	83.50"	24.75"	22.00"	(1) ADJ. DIVIDER	8	45.31"	23.00"	RIGHT STACK/ALS ACCESS
8.5	16.00"	23.00"	21.00"	BATTERY DRAWER	P1	88.50"	30.06"	SLIDING LIMO TINTED WINDOW 18" X 18"

DETAILS ARE CONCEPTUAL ONLY. LAYOUT AND ALL DIMENSIONS ARE APPROXIMATE AND SUBJECT TO MODIFICATION BY DESIGN ENGINEERING.

PROPRIETARY AND CONFIDENTIAL THIS INFORMATION CONTAINED IN THIS DRAWING IS THE SOLE PROPERTY OF ROAD RESCUE ANY REPRODUCTION IN PART OR AS A WHOLE WITHOUT THE WRITTEN PERMISSION OF ROAD RESCUE IS PROHIBITED.

Road Rescue
2737 N. FORSYTH RD
WINTER PARK, FL 32792
www.roadrescue.com PHONE 800-932-7077 FAX 800-513-2688

CURBSIDE EXTERIOR DETAIL

BID NUMBER

18949

DRAWN BY: GDG DATE: 09/12/2022 REVISION 1 REVISION 2 REVISION 3 SCALE SHEET 2 OF 10

NOTE: THIS DRAWING IS SUBJECT TO CHANGE PENDING ROAD RESCUE, INC. PRODUCTION ENGINEERING APPROVAL. © ROAD RESCUE, INC. ALL RIGHTS RESERVED.



TESS CORNERS VFD F-550 4 X 4 ULTRAMEDIC PASS-THROUGH

DEALER SIGNATURE

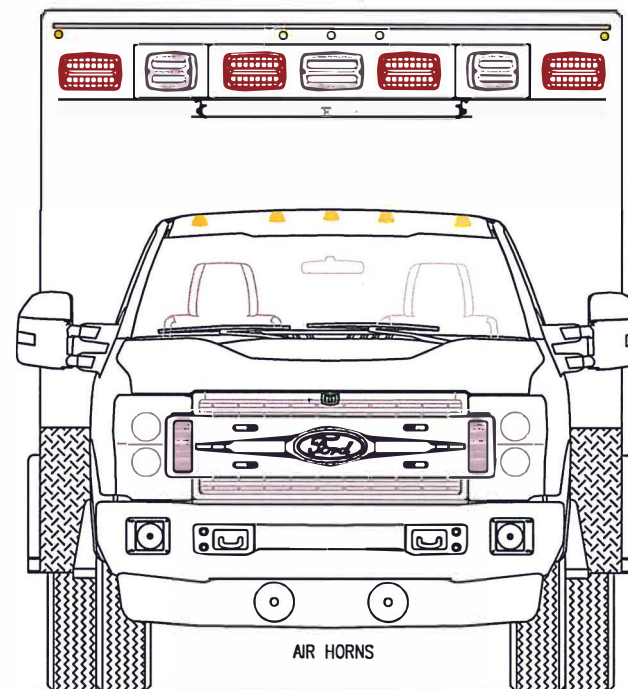
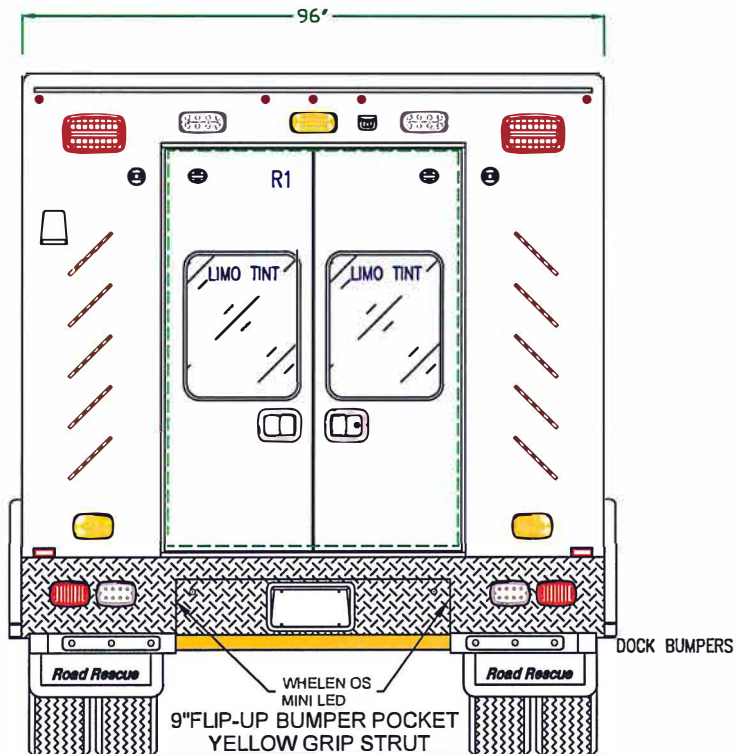

DOOR NO.	CLEAR OPENING		NOTES:
	HEIGHT	WIDTH	
R1	63.44"	50.25"	FIXED LIMO TINTED WINDOWS 18" X 24"

DETAILS ARE CONCEPTUAL ONLY.
LAYOUT AND ALL DIMENSIONS ARE APPROXIMATE AND
SUBJECT TO MODIFICATION BY DESIGN ENGINEERING.

PROPRIETARY AND CONFIDENTIAL
THIS INFORMATION CONTAINED IN THIS DRAWING IS THE SOLE PROPERTY OF ROAD RESCUE ANY REPRODUCTION IN PART OR AS A WHOLE WITHOUT THE WRITTEN PERMISSION OF ROAD RESCUE IS PROHIBITED.

Road Rescue
2737 N. FORSYTH RD
WINTER PARK, FL 32792
www.roadrescue.com PHONE 800-932-7077 FAX 800-513-2688

FRONT & REAR EXTERIOR DETAIL

BID NUMBER

DRAWN BY: GDG DATE: 09/12/2022 REVISION 1 REVISION 2 REVISION 3 SCALE: SHEET 3 OF 10

18949

NOTE: THIS DRAWING IS SUBJECT TO CHANGE PENDING ROAD RESCUE, INC. PRODUCTION ENGINEERING APPROVAL. ©ROAD RESCUE, INC. ALL RIGHTS RESERVED.



Road Rescue

In Service for Life™

TESS CORNERS VFD F-550 4 X 4 ULTRAMEDIC PASS-THROUGH

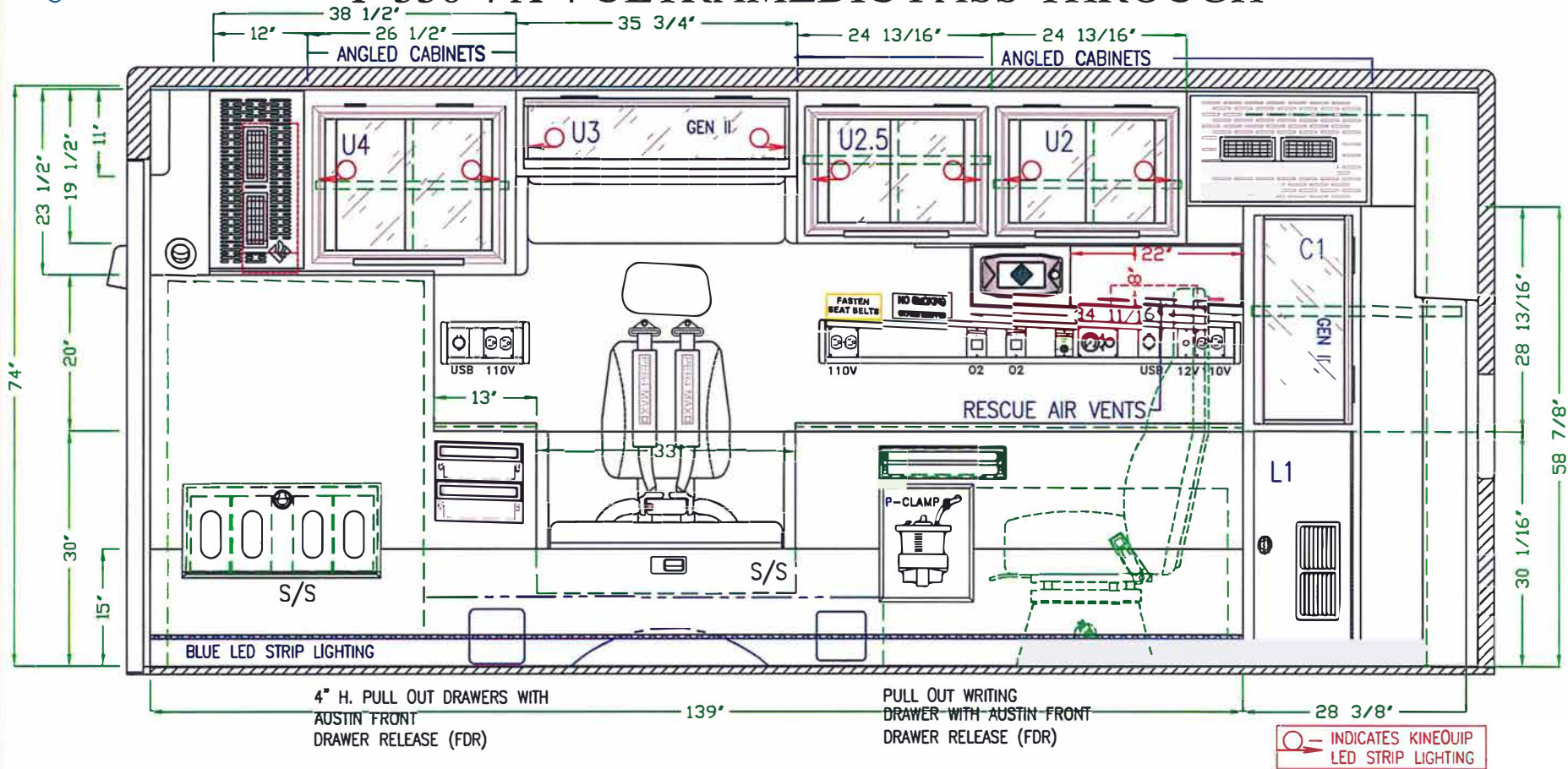

DOOR NO.	INTERIOR DIMENSIONS			NOTES
	HEIGHT	WIDTH	DEPTH	
C1	28.80"	28.37"	16.50"	GEN II OHO DOOR, (1) ADJ. SHELF
L1	30.06"	28.37"	16.50"	SINGLE ALUM. LOCKING DOOR,
U2	19.50"	24.50"	18.12"	SLIDING PLEX DOORS, (1) ADJ. SHELF, RESTOCK
U2.5	19.50"	24.50"	13.50"	SLIDING PLEX DOORS, (1) ADJ. SHELF, RESTOCK

DOOR NO.	INTERIOR DIMENSIONS			MISC. NOTES
	HEIGHT	WIDTH	DEPTH	
U3	11.00"	35.50"	10.75"	GEN II OHO DOOR, RESTOCKING
U4	23.50"	26.50"	18.12"	SLIDING PLEX DOORS, (1) ADJ. SHELF, RESTOCK

DETAILS ARE CONCEPTUAL ONLY.
LAYOUT AND ALL DIMENSIONS ARE APPROXIMATE AND SUBJECT TO MODIFICATION BY DESIGN ENGINEERING.

PROPRIETARY AND CONFIDENTIAL
THIS INFORMATION CONTAINED IN THIS DRAWING IS THE SOLE PROPERTY OF ROAD RESCUE ANY REPRODUCTION IN PART OR AS A WHOLE WITHOUT THE WRITTEN PERMISSION OF ROAD RESCUE IS PROHIBITED.

Road Rescue

2737 N. FORSYTH RD
WINTER PARK, FL 32792

www.roadrescue.com PHONE 800-932-7077 FAX 800-513-2688

STREETSIDE INTERIOR DETAIL

BID NUMBER

18949

DRAWN BY GDG	DATE 09/12/2022	REVISION 1	REVISION 2	REVISION 3	SCALE	SHEET 4 OF 10
-----------------	--------------------	------------	------------	------------	-------	---------------

NOTE: THIS DRAWING IS SUBJECT TO CHANGE PENDING ROAD RESCUE, INC. PRODUCTION ENGINEERING APPROVAL. © ROAD RESCUE, INC. ALL RIGHTS RESERVED.



TESS CORNERS VFD F-550 4 X 4 ULTRAMEDIC PASS-THROUGH

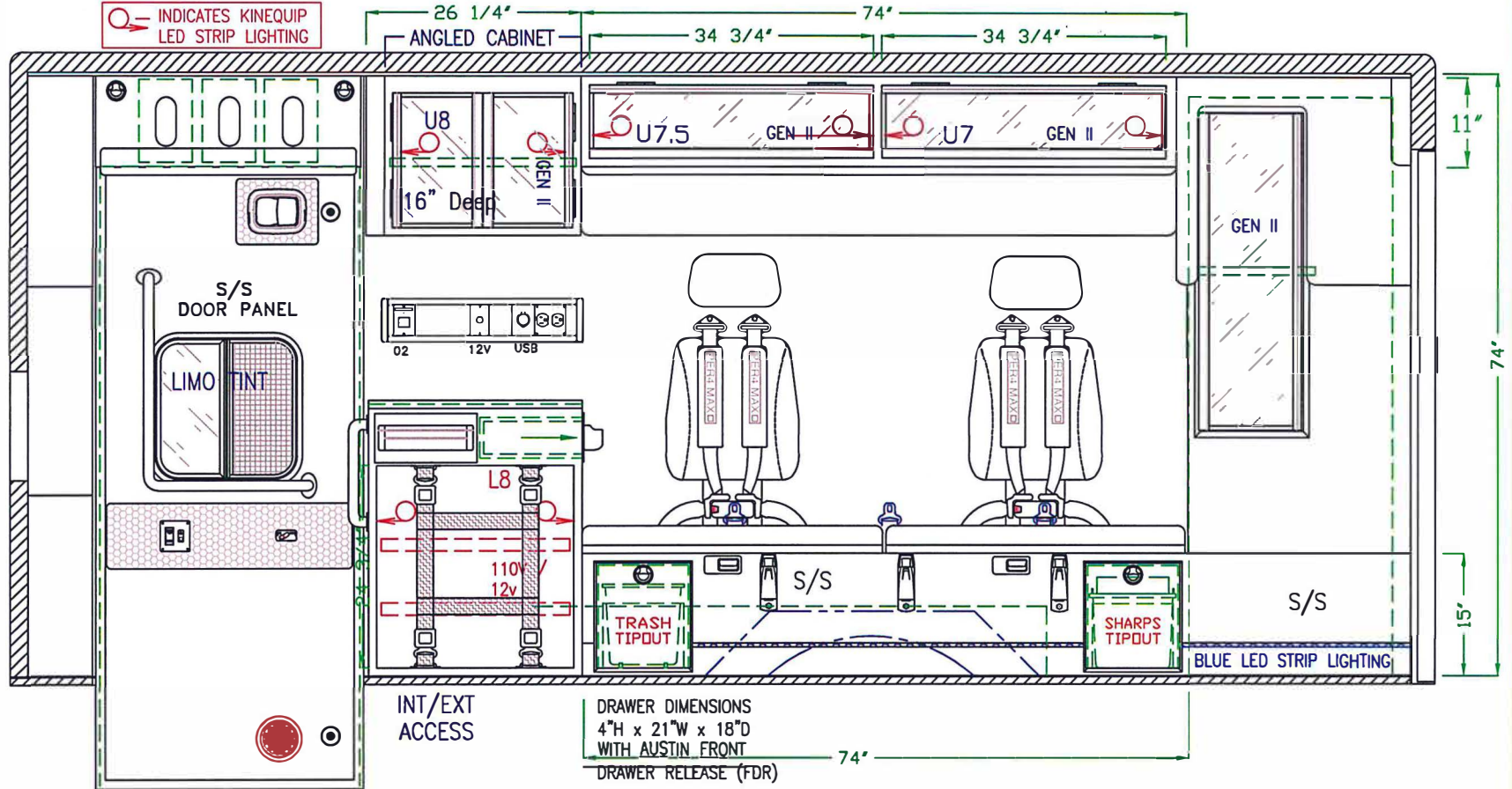

DOOR NO.	INTERIOR DIMENSIONS			NOTES
	HEIGHT	WIDTH	DEPTH	
U7	11.00"	38.00"	8.50"	GEN II DOOR, RESTOCKING
U7.5	11.00"	36.00"	8.50"	GEN II DOOR, RESTOCKING
U8	19.00"	26.00"	16.00"	GEN II DOORS, (1) ADJ. SHELF

NOTES:

DETAILS ARE CONCEPTUAL ONLY.
LAYOUT AND ALL DIMENSIONS ARE APPROXIMATE AND
SUBJECT TO MODIFICATION BY DESIGN ENGINEERING.

PROPRIETARY AND CONFIDENTIAL
THIS INFORMATION CONTAINED IN THIS DRAWING IS THE SOLE PROPERTY OF ROAD RESCUE ANY REPRODUCTION IN PART OR AS A WHOLE WITHOUT THE WRITTEN PERMISSION OF ROAD RESCUE IS PROHIBITED.

Road Rescue
2737 N. FORSYTH RD
WINTER PARK, FL 32792
www.roadrescue.com PHONE 800-932-7077 FAX 800-513-2688

CURBSIDE INTERIOR DETAIL

BID NUMBER
18949

DRAWN BY GDG	DATE 09/12/2022	REVISION 1	REVISION 2	REVISION 3	SCALE	SHEET 5 OF 10
-----------------	--------------------	------------	------------	------------	-------	---------------



TESS CORNERS VFD F-550 4 X 4 ULTRAMEDIC PASS-THROUGH

DEALER SIGNATURE 

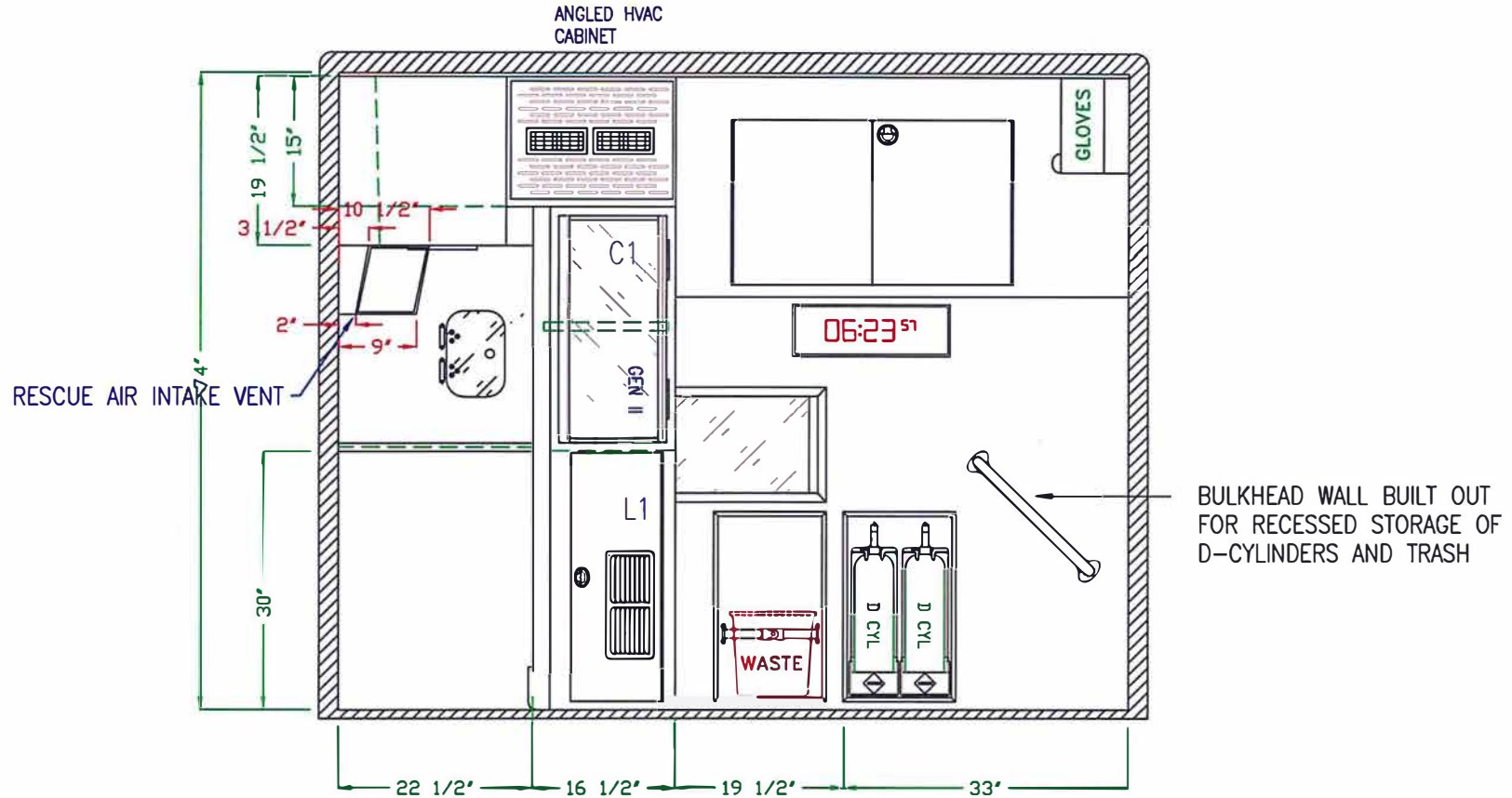

DOOR NO.	INTERIOR DIMENSIONS			NOTES
	HEIGHT	WIDTH	DEPTH	



NOTES:

DETAILS ARE CONCEPTUAL ONLY.
LAYOUT AND ALL DIMENSIONS ARE APPROXIMATE AND
SUBJECT TO MODIFICATION BY DESIGN ENGINEERING.

PROPRIETARY AND CONFIDENTIAL
THIS INFORMATION CONTAINED IN THIS DRAWING IS THE SOLE PROPERTY OF ROAD RESCUE ANY REPRODUCTION IN PART OR AS A WHOLE WITHOUT THE WRITTEN PERMISSION OF ROAD RESCUE IS PROHIBITED.

Road Rescue 2737 N. FORSYTH RD
WINTER PARK, FL 32792
www.roadrescue.com PHONE 800-932-7077 FAX 800-513-2688

FRONT INTERIOR DETAIL

BID NUMBER
 18949 

DRAWN BY GDC DATE 09/12/2022 REVISION 1 REVISION 2 REVISION 3 SCALE SHEET 6 OF 10



TESS CORNERS VFD F-550 4 X 4 ULTRAMEDIC PASS-THROUGH

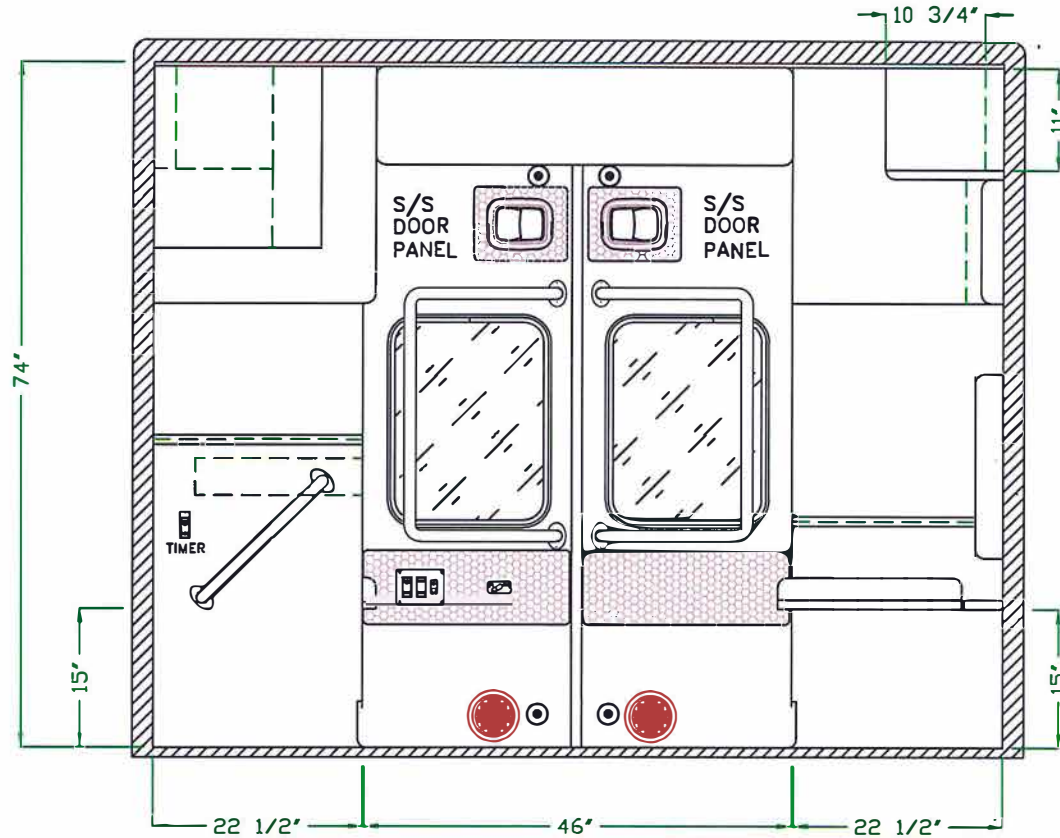

NOTES:

NOTES:
 DETAILS ARE CONCEPTUAL ONLY.
 LAYOUT AND ALL DIMENSIONS ARE APPROXIMATE AND
 SUBJECT TO MODIFICATION BY DESIGN ENGINEERING.

PROPRIETARY AND
 CONFIDENTIAL
 THIS INFORMATION
 CONTAINED IN THIS
 DRAWING IS THE SOLE
 PROPERTY OF ROAD
 RESCUE ANY
 REPRODUCTION IN PART
 OR AS A WHOLE
 WITHOUT THE WRITTEN
 PERMISSION OF ROAD
 RESCUE IS PROHIBITED.

Road Rescue 2737 N. FORSYTH RD
 WINTER PARK, FL 32792
 www.roadrescue.com PHONE 800-932-7077 FAX 800-513-2688

REAR INTERIOR DETAIL

BID NUMBER

DRAWN BY GDG	DATE 09/12/2022	REVISION 1	REVISION 2	REVISION 3	SCALE	SHEET 7 OF 10
-----------------	--------------------	------------	------------	------------	-------	---------------

18949



Road Rescue
In Service for Life™

TESS CORNERS VFD F-550 4 X 4 ULTRAMEDIC PASS-THROUGH

DEALER SIGNATURE

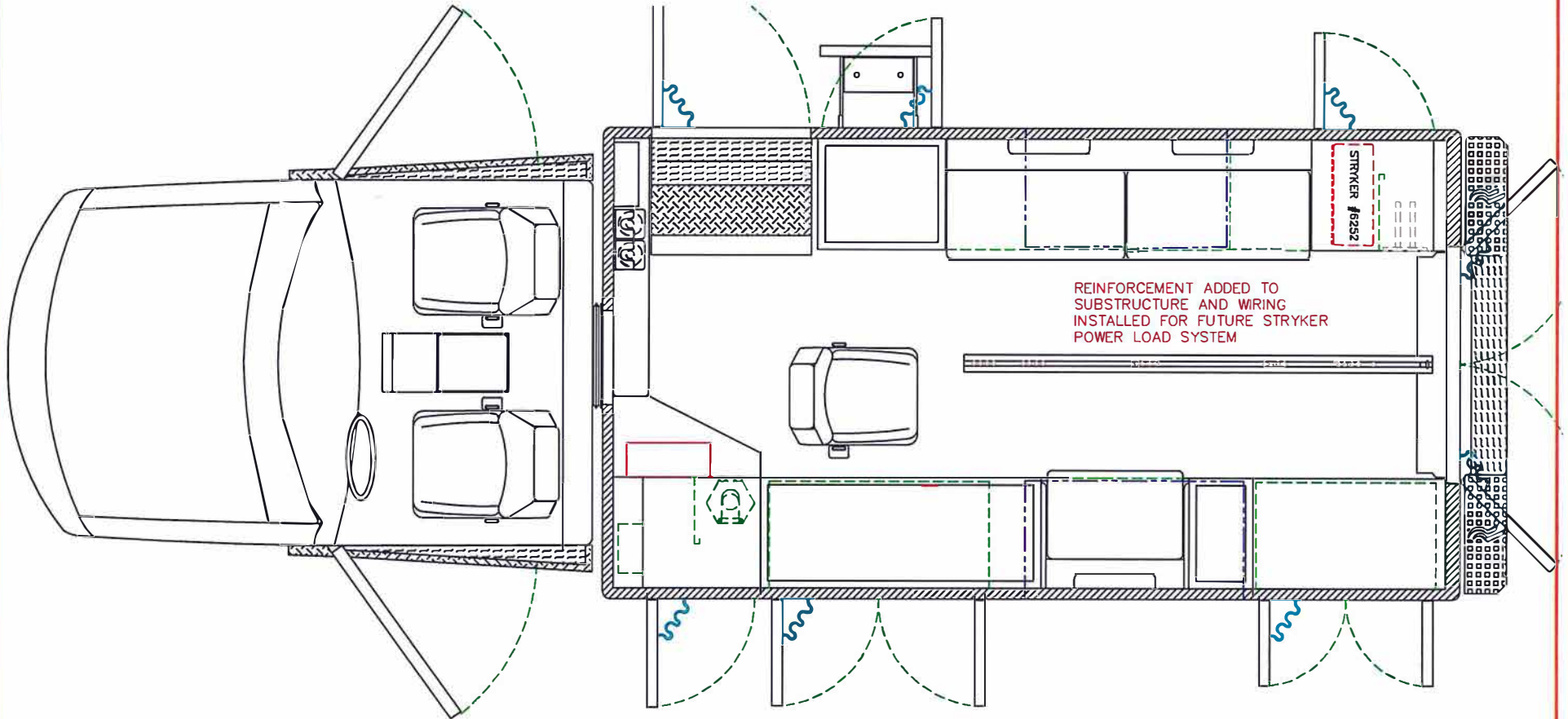

NOTES:

NOTES:

DETAILS ARE CONCEPTUAL ONLY.
LAYOUT AND ALL DIMENSIONS ARE APPROXIMATE AND
SUBJECT TO MODIFICATION BY DESIGN ENGINEERING.

PROPRIETARY AND
CONFIDENTIAL
THIS INFORMATION
CONTAINED IN THIS
DRAWING IS THE SOLE
PROPERTY OF ROAD
RESCUE ANY
REPRODUCTION IN PART
OR AS A WHOLE
WITHOUT THE WRITTEN
PERMISSION OF ROAD
RESCUE IS PROHIBITED.

Road Rescue

2737 N. FORSYTH RD
WINTER PARK, FL 32792

www.roadrescue.com PHONE 800-932-7077 FAX 800-513-2688

DRAWN BY GDG	DATE 09/12/2022	REVISION 1	REVISION 2	REVISION 3	SCALE
-----------------	--------------------	------------	------------	------------	-------

OVERHEAD FLOOR DETAIL

BID NUMBER



18949



SHEET 8 OF 10

NOTE: THIS DRAWING IS SUBJECT TO CHANGE PENDING ROAD RESCUE, INC. PRODUCTION ENGINEERING APPROVAL. ©ROAD RESCUE, INC. ALL RIGHTS RESERVED.



TESS CORNERS VFD F-550 4 X 4 ULTRAMEDIC PASS-THROUGH

DEALER SIGNATURE

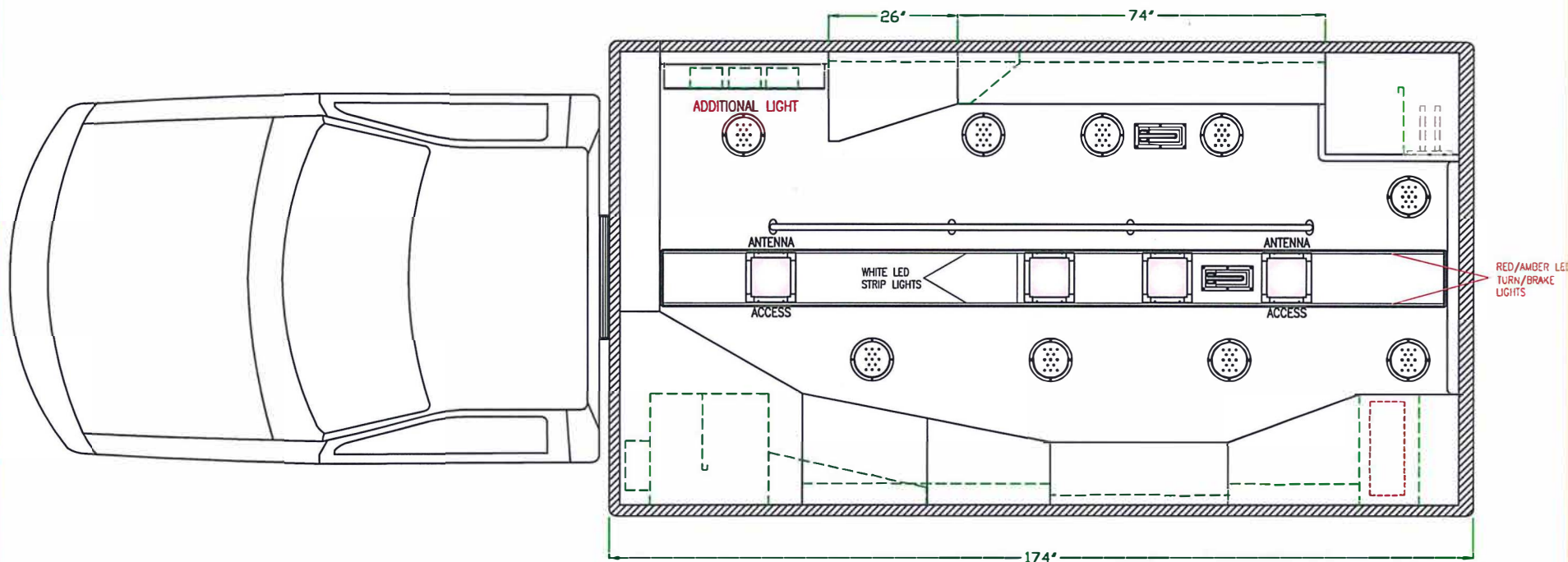

NOTES:

NOTES:
 DETAILS ARE CONCEPTUAL ONLY.
 LAYOUT AND ALL DIMENSIONS ARE APPROXIMATE AND
 SUBJECT TO MODIFICATION BY DESIGN ENGINEERING.

PROPRIETARY AND
 CONFIDENTIAL
 THIS INFORMATION
 CONTAINED IN THIS
 DRAWING IS THE SOLE
 PROPERTY OF ROAD
 RESCUE ANY
 REPRODUCTION IN PART
 OR AS A WHOLE
 WITHOUT THE WRITTEN
 PERMISSION OF ROAD
 RESCUE IS PROHIBITED.

Road Rescue
 2737 N. FORSYTH RD
 WINTER PARK, FL 32792
 www.roadrescue.com PHONE 800-932-7077 FAX 800-513-2688

OVERHEAD CEILING DETAIL

BID NUMBER

DRAWN BY: GDC DATE: 09/12/2022 REVISION 1 REVISION 2 REVISION 3 SCALE: SHEET 9 OF 10

18949

NOTE: THIS DRAWING IS SUBJECT TO CHANGE PENDING ROAD RESCUE, INC. PRODUCTION ENGINEERING APPROVAL. © ROAD RESCUE, INC. ALL RIGHTS RESERVED.



TESS CORNERS VFD F550 ULTRAMEDIC



TOP OF CONSOLE SHALL BE
JUST BELOW CAB HVAC CONTROLS.
THERE WILL BE A .5" GAP FROM
DASH TO CONSOLE

DESIGN AS LONG AS POSSIBLE
FROM FLUID DAM TO DASH

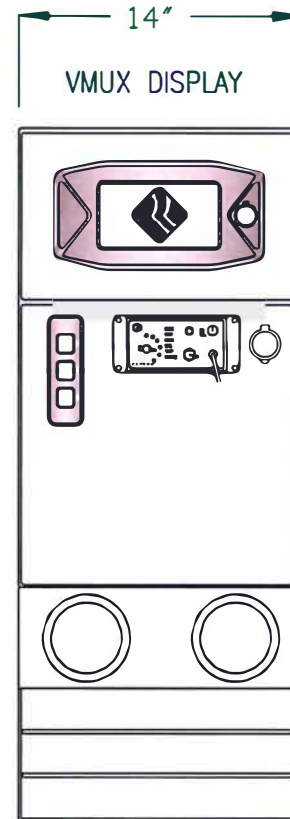
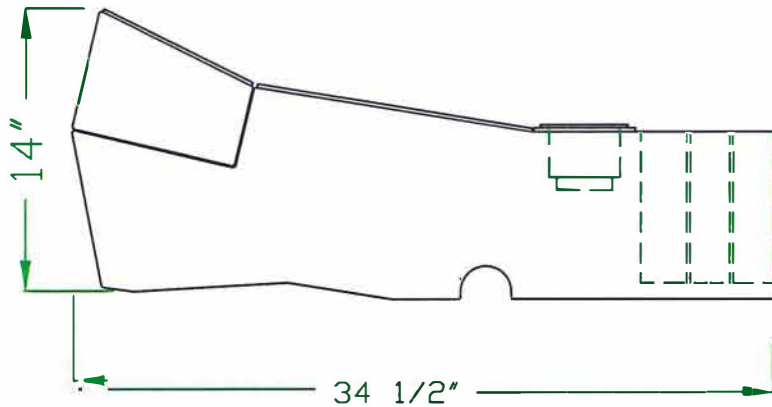

14"
VMUX DISPLAY

BLACK SCORPION COATED
WITH LAMINATED PANELS

DUAL USB

CUP HOLDERS

MAP STORAGE

PROPRIETARY AND
CONFIDENTIAL
THIS INFORMATION
CONTAINED IN THIS
DRAWING IS THE SOLE
PROPERTY OF ROAD
RESCUE ANY
REPRODUCTION IN PART
OR AS A WHOLE
WITHOUT THE WRITTEN
PERMISSION OF ROAD
RESCUE IS PROHIBITED.

DETAILS ARE CONCEPTUAL ONLY. LAYOUT AND ALL DIMENSIONS ARE
APPROXIMATE AND SUBJECT TO MODIFICATION BY DESIGN ENGINEERING.

Road Rescue

2737 N. FORSYTH ROAD
WINTER PARK, FL 32792

www.roadrescue.com PHONE 800-932-7077 FAX 800-513-2688

CONSOLE CONFIGURATION

BID NUMBER

18949

DRAWN BY	DATE	REVISION 1	REVISION 2	REVISION 3	SCALE
----------	------	------------	------------	------------	-------

SHEET 10 OF 10		
----------------	--	--

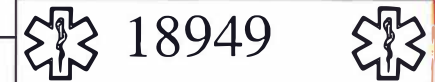

NOTE: THIS DRAWING IS SUBJECT TO CHANGE PENDING ROAD RESCUE PRODUCTION ENGINEERING APPROVAL. © ROAD RESCUE ALL RIGHTS RESERVED.



POLK CITY FIRE DEPARTMENT F-550 4 X 4 ULTRAMEDIC PASS-THROUGH



DO NOT CUT HOLES FOR COMPARTMENT LIGHTING

F INDICATES A FULL HEIGHT FLEXIBLE LIGHTING STRIP

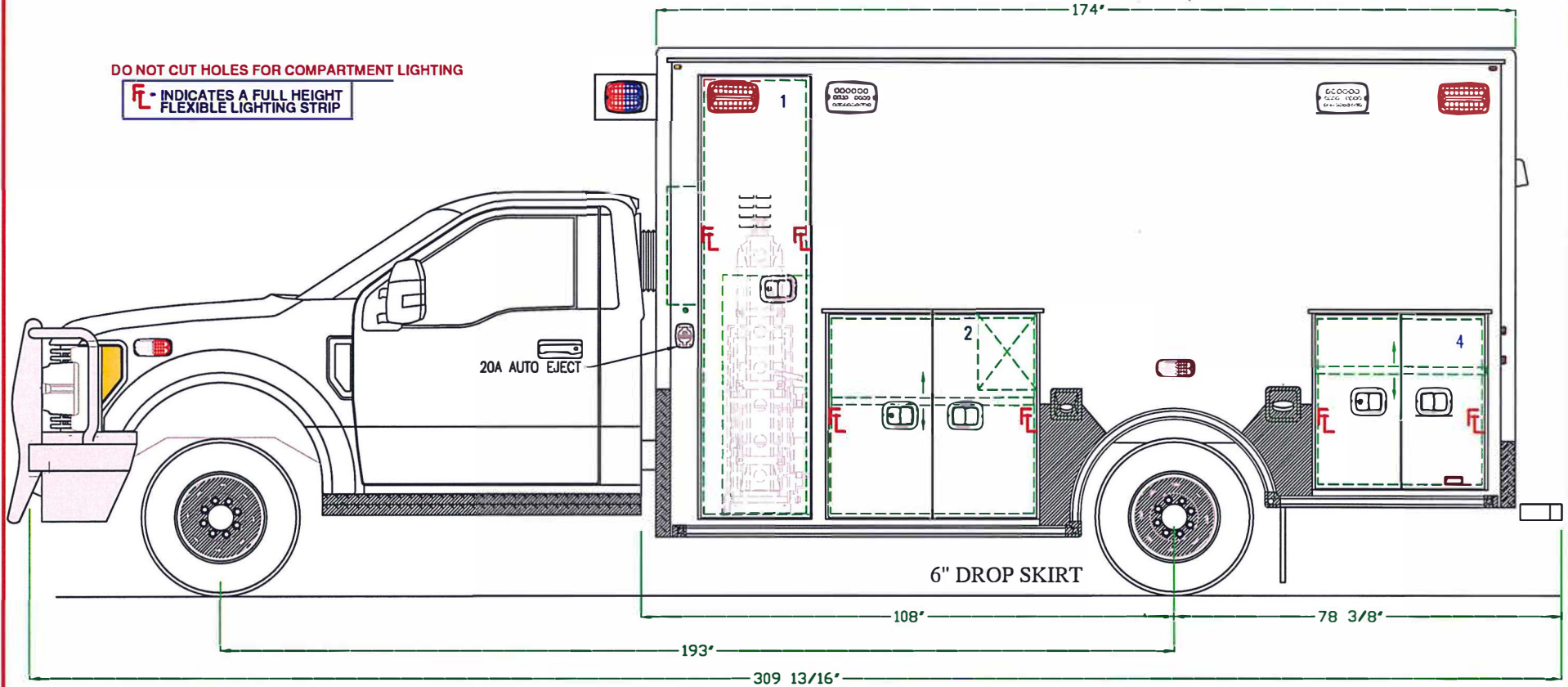

DOOR NO.	INTERIOR DIMENSIONS			NOTES
	HEIGHT	WIDTH	DEPTH	
1	89.50"	23.25"	22.00"	ZICO O2 LIFT
2	41.50"	43.88"	21.25"	(1) ADJ. SHELF
4	35.50"	35.50"	21.25"	(1) ADJ. SHELF

NOTES:
BLACKOUT PACKAGE AS SHOWN

DETAILS ARE CONCEPTUAL ONLY.
LAYOUT AND ALL DIMENSIONS ARE APPROXIMATE AND SUBJECT TO MODIFICATION BY DESIGN ENGINEERING.

PROPRIETARY AND CONFIDENTIAL
THIS INFORMATION CONTAINED IN THIS DRAWING IS THE SOLE PROPERTY OF ROAD RESCUE ANY REPRODUCTION IN PART OR AS A WHOLE WITHOUT THE WRITTEN PERMISSION OF ROAD RESCUE IS PROHIBITED.

Road Rescue
2737 N. FORSYTH RD
WINTER PARK, FL 32792
www.roadrescue.com PHONE 800-932-7077 FAX 800-513-2688

STREETSIDE EXTERIOR DETAIL

BID NUMBER

DRAWN BY GDG	DATE 12/08/2022	REVISION 1	REVISION 2	REVISION 3	SCALE	SHEET 1 OF 10
-----------------	--------------------	------------	------------	------------	-------	---------------

18982

NOTE: THIS DRAWING IS SUBJECT TO CHANGE PENDING ROAD RESCUE PRODUCTION ENGINEERING APPROVAL. © ROAD RESCUE ALL RIGHTS RESERVED.



POLK CITY FIRE DEPARTMENT F-550 4 X 4 ULTRAMEDIC PASS-THROUGH

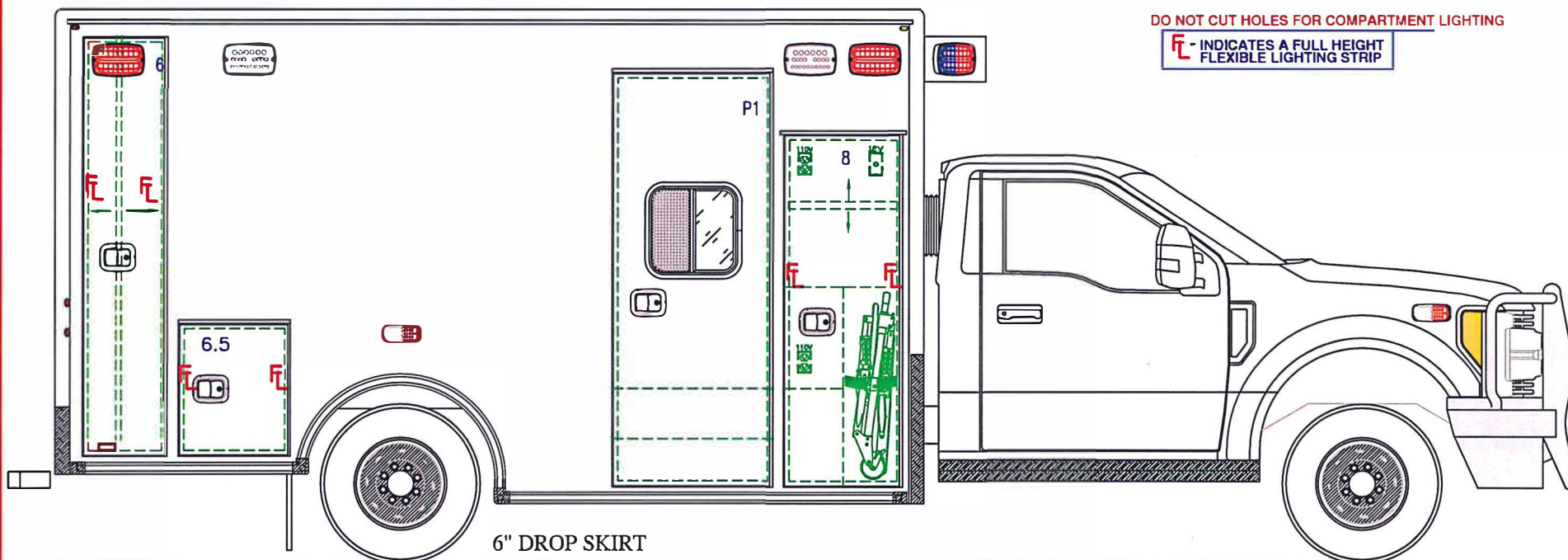

DOOR NO.	INTERIOR DIMENSIONS			NOTES	DOOR NO.	DOOR DIMENSIONS		MISC. NOTES
	HEIGHT	WIDTH	DEPTH			HEIGHT	WIDTH	
6	83.50"	16.75"	22.00"	(1) ADJ. DIVIDER	8	70.50"	23.00"	RIGHT STACK/ALS ACCESS, STAIR CHAIR STORAGE
6.5	25.50"	22.25"	17.25"		P1	83.00"	30.06"	SLIDING TINTED WINDOW 18" X 18"
DETAILS ARE CONCEPTUAL ONLY. LAYOUT AND ALL DIMENSIONS ARE APPROXIMATE AND SUBJECT TO MODIFICATION BY DESIGN ENGINEERING.								
PROPRIETARY AND CONFIDENTIAL THIS INFORMATION CONTAINED IN THIS DRAWING IS THE SOLE PROPERTY OF ROAD RESCUE ANY REPRODUCTION IN PART OR AS A WHOLE WITHOUT THE WRITTEN PERMISSION OF ROAD RESCUE IS PROHIBITED.								

Road Rescue
 2737 N. FORSYTH RD
 WINTER PARK, FL 32792
 www.roadrescue.com PHONE 800-932-7077 FAX 800-513-2688

CURBSIDE EXTERIOR DETAIL

BID NUMBER

DRAWN BY: GDG
 DATE: 12/08/2022
 REVISION 1
 REVISION 2
 REVISION 3
 SCALE
 SHEET 2 OF 10

18982

NOTE: THIS DRAWING IS SUBJECT TO CHANGE PENDING ROAD RESCUE PRODUCTION ENGINEERING APPROVAL. © ROAD RESCUE ALL RIGHTS RESERVED.



POLK CITY FIRE DEPARTMENT F-550 4 X 4 ULTRAMEDIC PASS-THROUGH

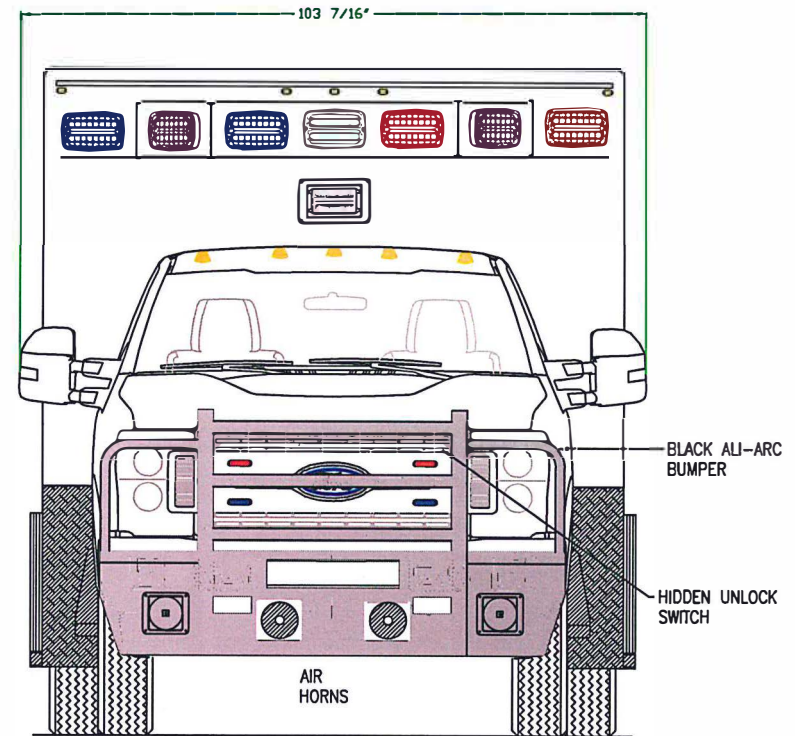
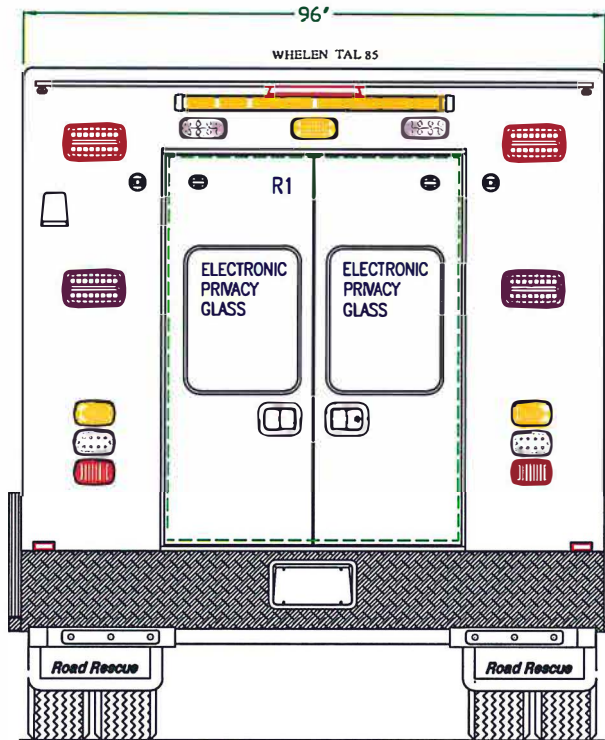

DOOR NO.	CLEAR OPENING		NOTES:
	HEIGHT	WIDTH	
R1	61.44"	50.25"	FIXED TINTED WINDOWS 18" X 24"

DETAILS ARE CONCEPTUAL ONLY.
LAYOUT AND ALL DIMENSIONS ARE APPROXIMATE AND
SUBJECT TO MODIFICATION BY DESIGN ENGINEERING.

PROPRIETARY AND CONFIDENTIAL
THIS INFORMATION CONTAINED IN THIS DRAWING IS THE SOLE PROPERTY OF ROAD RESCUE ANY REPRODUCTION IN PART OR AS A WHOLE WITHOUT THE WRITTEN PERMISSION OF ROAD RESCUE IS PROHIBITED.

Road Rescue
2737 N. FORSYTH RD
WINTER PARK, FL 32792
www.roadrescue.com PHONE 800-932-7077 FAX 800-513-2688

FRONT & REAR EXTERIOR DETAIL

BID NUMBER

DRAWN BY: GDG DATE: 12/08/2022 REVISION 1 REVISION 2 REVISION 3 SCALE SHEET 3 OF 10

18982

NOTE: THIS DRAWING IS SUBJECT TO CHANGE PENDING ROAD RESCUE PRODUCTION ENGINEERING APPROVAL. © ROAD RESCUE ALL RIGHTS RESERVED.



POLK CITY FIRE DEPARTMENT F-550 4 X 4 ULTRAMEDIC PASS-THROUGH

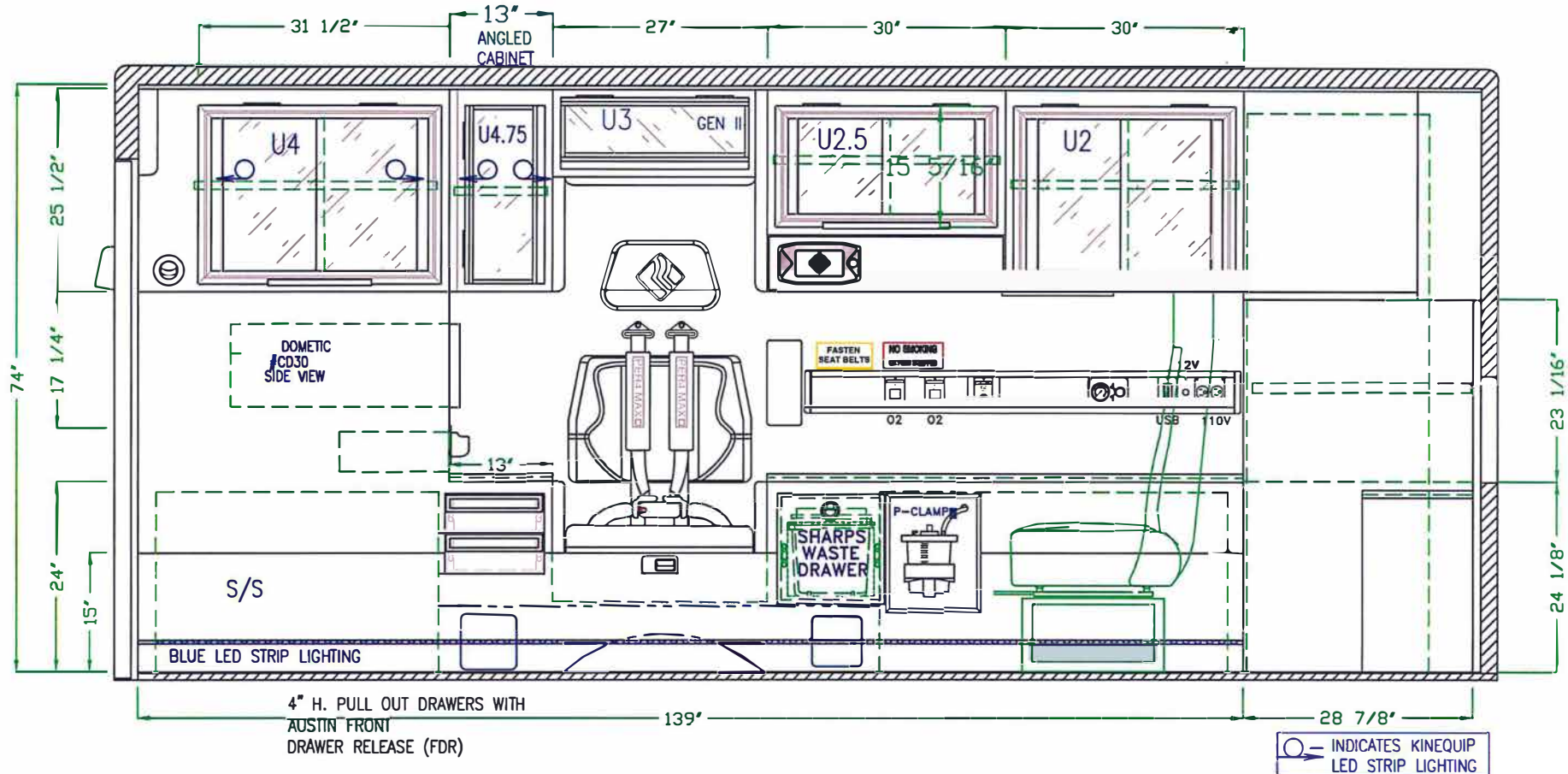

DOOR NO.	INTERIOR DIMENSIONS			NOTES
	HEIGHT	WIDTH	DEPTH	
C1	23.00"	28.50"	16.50"	DOUBLE ALUM. LOCKING DOOR, (1) ADJ. SHELF
L1	23.62"	28.50"	16.50"	DOUBLE ALUM. LOCKING DOOR,
U2	18.00"	29.50"	18.12"	SLIDING POLY DOORS, (1) ADJ. SHELF, RESTOCKING
U2.5	25.50"	29.50"	18.12"	SLIDING POLY DOORS, (1) ADJ. SHELF, RESTOCKING

DOOR NO.	INTERIOR DIMENSIONS			MISC. NOTES
	HEIGHT	WIDTH	DEPTH	
U4	25.50"	31.50"	18.12"	SLIDING POLY DOORS, (1) ADJ. SHELF, RESTOCK

DETAILS ARE CONCEPTUAL ONLY. LAYOUT AND ALL DIMENSIONS ARE APPROXIMATE AND SUBJECT TO MODIFICATION BY DESIGN ENGINEERING.

PROPRIETARY AND CONFIDENTIAL
THIS INFORMATION CONTAINED IN THIS DRAWING IS THE SOLE PROPERTY OF ROAD RESCUE ANY REPRODUCTION IN PART OR AS A WHOLE WITHOUT THE WRITTEN PERMISSION OF ROAD RESCUE IS PROHIBITED.

Road Rescue
2737 N. FORSYTH RD
WINTER PARK, FL 32792
www.roadrescue.com PHONE 800-932-7077 FAX 800-513-2688

STREETSIDE INTERIOR DETAIL

BID NUMBER
 18982

DRAWN BY: GDG DATE: 12/08/2022 REVISION 1 REVISION 2 REVISION 3 SCALE: SHEET 4 OF 10

NOTE: THIS DRAWING IS SUBJECT TO CHANGE PENDING ROAD RESCUE PRODUCTION ENGINEERING APPROVAL. © ROAD RESCUE ALL RIGHTS RESERVED.



POLK CITY FIRE DEPARTMENT F-550 4 X 4 ULTRAMEDIC PASS-THROUGH

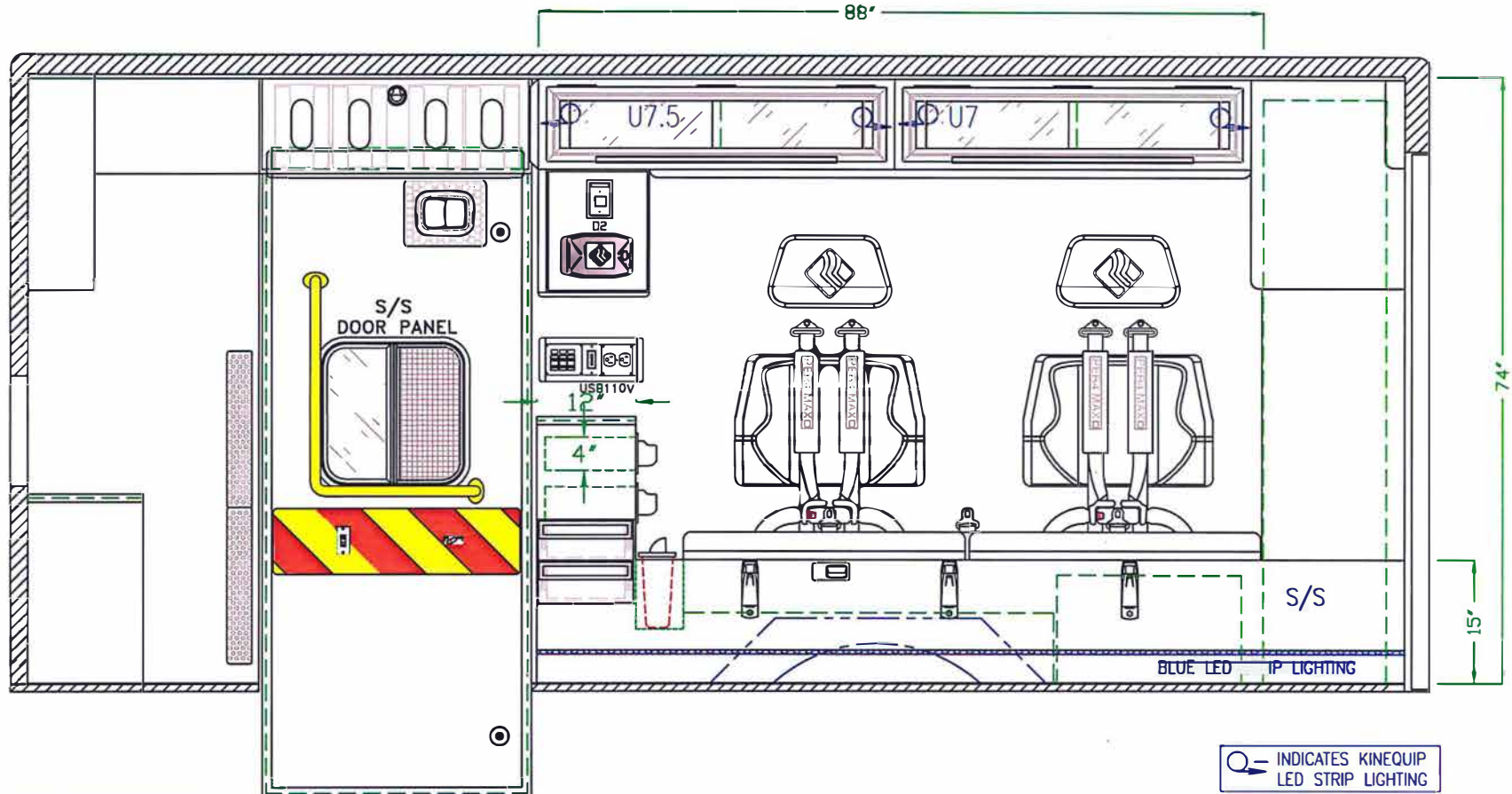

DOOR NO.	INTERIOR DIMENSIONS			NOTES
	HEIGHT	WIDTH	DEPTH	
U7	11.00"	44.00"	8.50"	SLIDING POLY DOORS, RESTOCKING
U7.5	11.00"	44.00"	8.50"	SLIDING POLY DOORS, RESTOCKING

NOTES:
 DETAILS ARE CONCEPTUAL ONLY.
 LAYOUT AND ALL DIMENSIONS ARE APPROXIMATE AND
 SUBJECT TO MODIFICATION BY DESIGN ENGINEERING.

PROPRIETARY AND CONFIDENTIAL
 THIS INFORMATION CONTAINED IN THIS DRAWING IS THE SOLE PROPERTY OF ROAD RESCUE ANY REPRODUCTION IN PART OR AS A WHOLE WITHOUT THE WRITTEN PERMISSION OF ROAD RESCUE IS PROHIBITED.

Road Rescue
 2737 N. FORSYTH RD
 WINTER PARK, FL 32792
 www.roadrescue.com PHONE 800-932-7077 FAX 800-513-2688

CURBSIDE INTERIOR DETAIL

BID NUMBER

18982

DRAWN BY GDG	DATE 12/08/2022	REVISION 1	REVISION 2	REVISION 3	SCALE	SHEET 5 OF 10
-----------------	--------------------	------------	------------	------------	-------	---------------

NOTE: THIS DRAWING IS SUBJECT TO CHANGE PENDING ROAD RESCUE PRODUCTION ENGINEERING APPROVAL. © ROAD RESCUE ALL RIGHTS RESERVED.



POLK CITY FIRE DEPARTMENT F-550 4 X 4 ULTRAMEDIC PASS-THROUGH

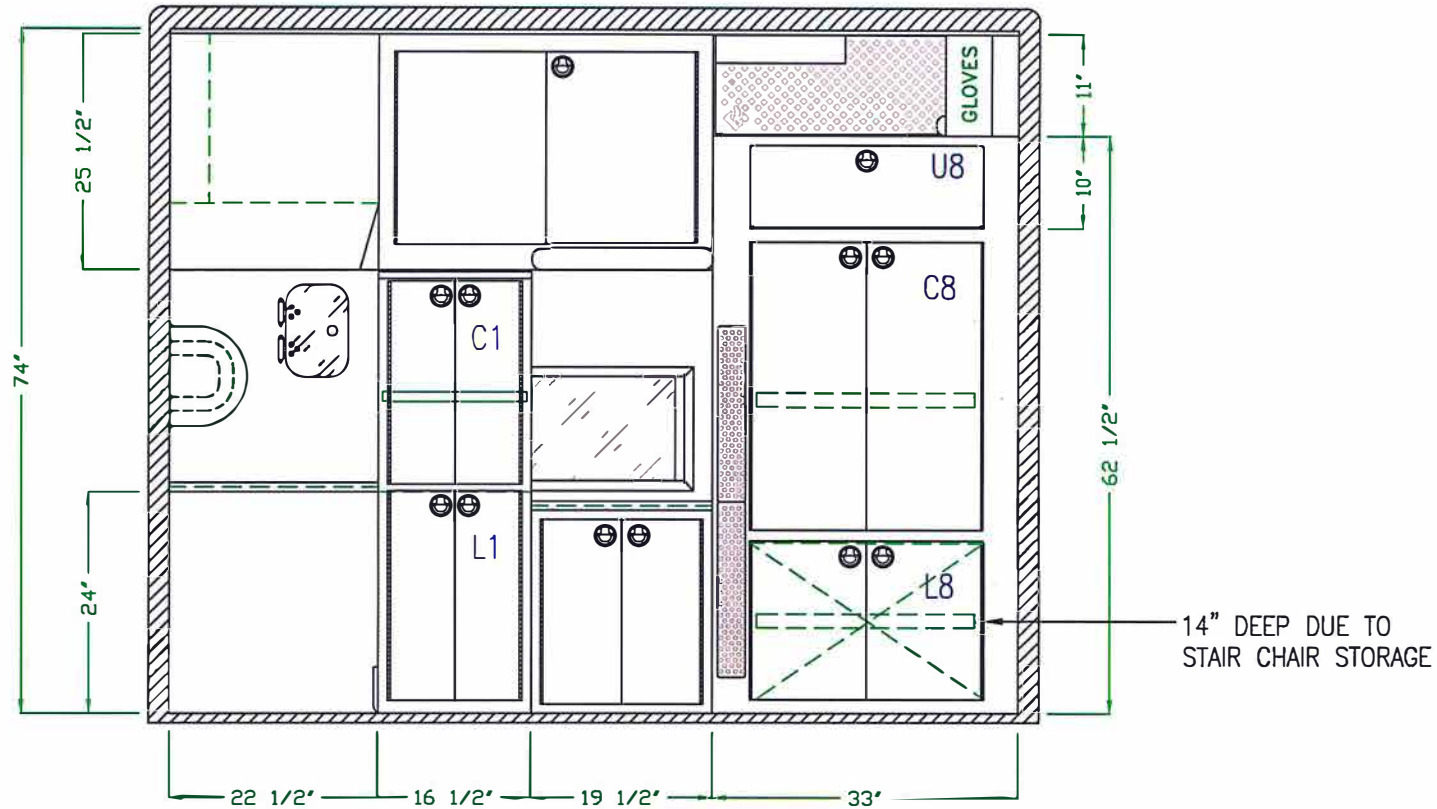
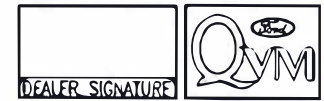

DOOR NO.	INTERIOR DIMENSIONS			NOTES
	HEIGHT	WIDTH	DEPTH	
U8	10.00"	28.00"	26.00"	SINGLE ALUM. DOOR, LOCKING LATCH
C8	31.50"	28.00"	26.00"	LOCKING ALUMINUM DOORS
L8	17.50"	28.00"	14.00"	LOCKING ALUMINUM DOORS

NOTES:
 DETAILS ARE CONCEPTUAL ONLY.
 LAYOUT AND ALL DIMENSIONS ARE APPROXIMATE AND
 SUBJECT TO MODIFICATION BY DESIGN ENGINEERING.

PROPRIETARY AND CONFIDENTIAL
 THIS INFORMATION CONTAINED IN THIS DRAWING IS THE SOLE PROPERTY OF ROAD RESCUE ANY REPRODUCTION IN PART OR AS A WHOLE WITHOUT THE WRITTEN PERMISSION OF ROAD RESCUE IS PROHIBITED.

Road Rescue 2737 N. FORSYTH RD
 WINTER PARK, FL 32792
 www.roadrescue.com PHONE 800-932-7077 FAX 800-513-2688

FRONT INTERIOR DETAIL

BID NUMBER
 **18982** 

DRAWN BY GDG	DATE 12/08/2022	REVISION 1	REVISION 2	REVISION 3	SCALE	SHEET 6 OF 10
-----------------	--------------------	------------	------------	------------	-------	---------------

NOTE: THIS DRAWING IS SUBJECT TO CHANGE PENDING ROAD RESCUE PRODUCTION ENGINEERING APPROVAL. © ROAD RESCUE ALL RIGHTS RESERVED.



POLK CITY FIRE DEPARTMENT F-550 4 X 4 ULTRAMEDIC PASS-THROUGH

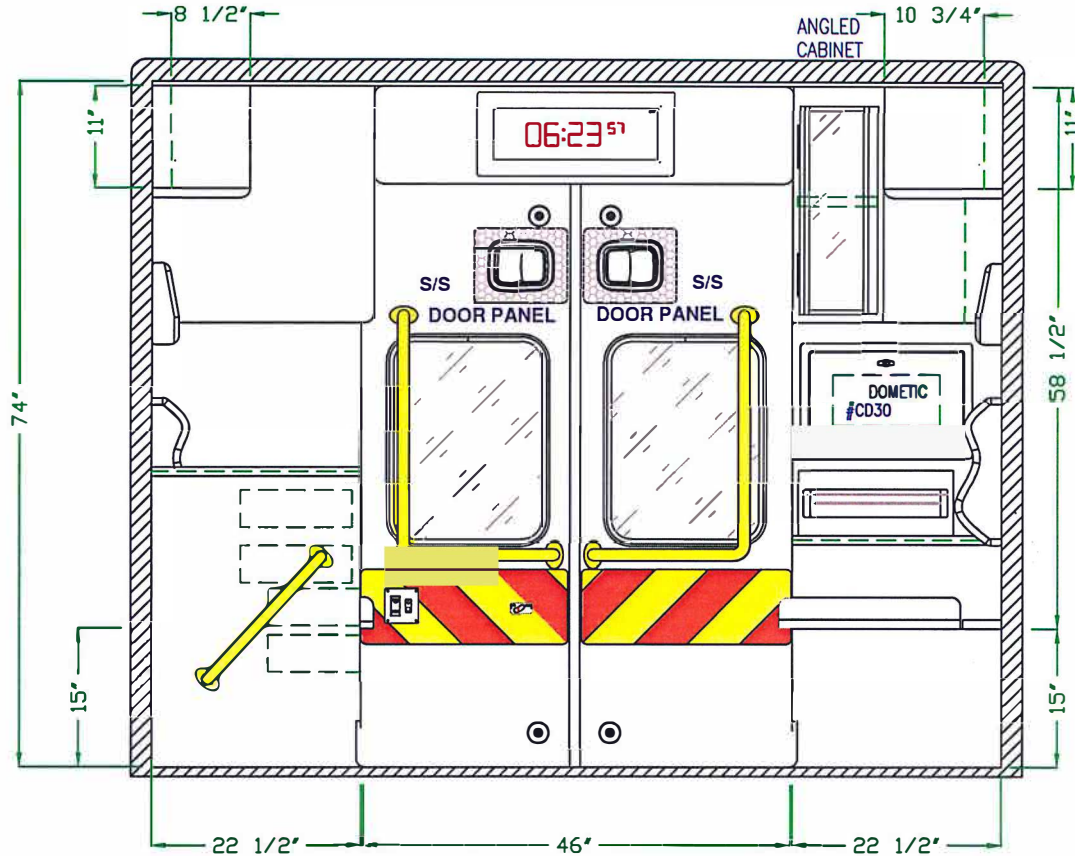

NOTES:

NOTES:

DETAILS ARE CONCEPTUAL ONLY.
LAYOUT AND ALL DIMENSIONS ARE APPROXIMATE AND
SUBJECT TO MODIFICATION BY DESIGN ENGINEERING.

PROPRIETARY AND
CONFIDENTIAL
THIS INFORMATION
CONTAINED IN THIS
DRAWING IS THE SOLE
PROPERTY OF ROAD
RESCUE ANY
REPRODUCTION IN PART
OR AS A WHOLE
WITHOUT THE WRITTEN
PERMISSION OF ROAD
RESCUE IS PROHIBITED.

Road Rescue 2737 N. FORSYTH RD
WINTER PARK, FL 32792

www.roadrescue.com PHONE 800-932-7077 FAX 800-513-2688

DRAWN BY DATE REVISION 1 REVISION 2 REVISION 3 SCALE

GDG 12/08/2022

REAR INTERIOR DETAIL

BID NUMBER

18982

SHEET 7 OF 10

NOTE: THIS DRAWING IS SUBJECT TO CHANGE PENDING ROAD RESCUE PRODUCTION ENGINEERING APPROVAL. © ROAD RESCUE ALL RIGHTS RESERVED.



POLK CITY FIRE DEPARTMENT F-550 4 X 4 ULTRAMEDIC PASS-THROUGH

DEALER SIGNATURE	QYM
------------------	-----

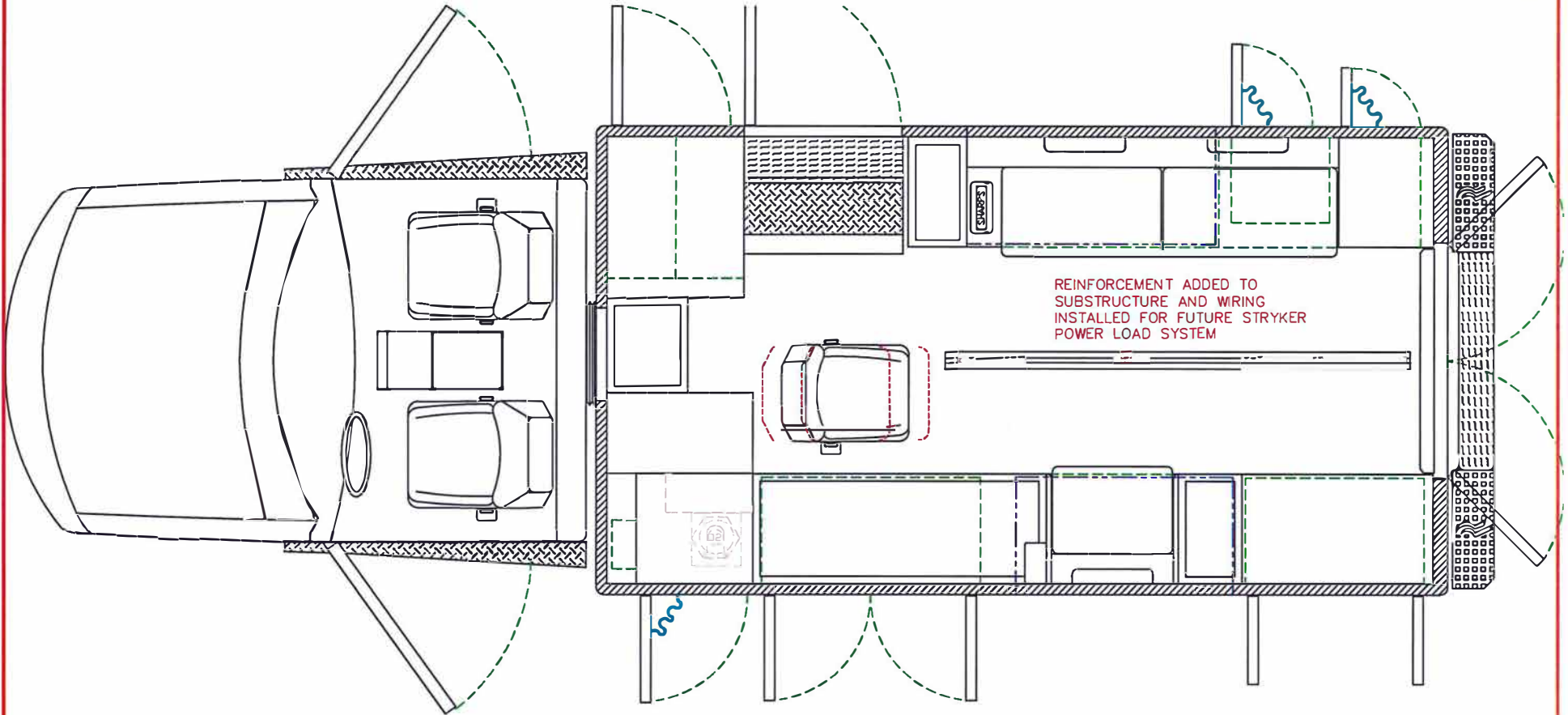

NOTES:

NOTES:

DETAILS ARE CONCEPTUAL ONLY.
LAYOUT AND ALL DIMENSIONS ARE APPROXIMATE AND
SUBJECT TO MODIFICATION BY DESIGN ENGINEERING.

PROPRIETARY AND
CONFIDENTIAL
THIS INFORMATION
CONTAINED IN THIS
DRAWING IS THE SOLE
PROPERTY OF ROAD
RESCUE ANY
REPRODUCTION IN PART
OR AS A WHOLE
WITHOUT THE WRITTEN
PERMISSION OF ROAD
RESCUE IS PROHIBITED.

Road Rescue 2737 N. FORSYTH RD
WINTER PARK, FL 32792
www.roadrescue.com PHONE 800-932-7077 FAX 800-513-2688

OVERHEAD FLOOR DETAIL

BI D NUMBER
 18982

DRAWN BY GDG	DATE 12/08/2022	REVISION 1	REVISION 2	REVISION 3	SCALE	SHEET 8 OF 10
-----------------	--------------------	------------	------------	------------	-------	---------------

NOTE: THIS DRAWING IS SUBJECT TO CHANGE PENDING ROAD RESCUE PRODUCTION ENGINEERING APPROVAL. © ROAD RESCUE ALL RIGHTS RESERVED.



POLK CITY FIRE DEPARTMENT F-550 4 X 4 ULTRAMEDIC PASS-THROUGH

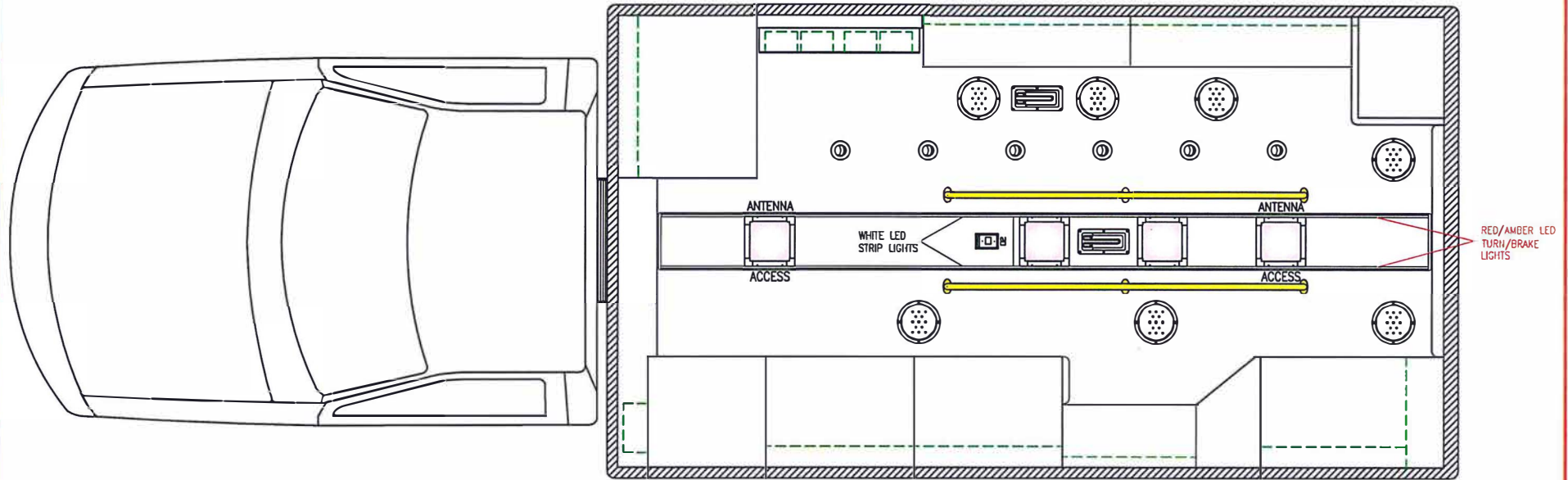

NOTES:

NOTES:

DETAILS ARE CONCEPTUAL ONLY.
LAYOUT AND ALL DIMENSIONS ARE APPROXIMATE AND
SUBJECT TO MODIFICATION BY DESIGN ENGINEERING.

PROPRIETARY AND
CONFIDENTIAL
THIS INFORMATION
CONTAINED IN THIS
DRAWING IS THE SOLE
PROPERTY OF ROAD
RESCUE ANY
REPRODUCTION IN PART
OR AS A WHOLE
WITHOUT THE WRITTEN
PERMISSION OF ROAD
RESCUE IS PROHIBITED.

Road Rescue

2737 N. FORSYTH RD
WINTER PARK, FL 32792

www.roadrescue.com PHONE 800-932-7077 FAX 800-513-2688

DRAWN BY GDG	DATE 12/08/2022	REVISION 1	REVISION 2	REVISION 3	SCALE
-----------------	--------------------	------------	------------	------------	-------

OVERHEAD CEILING DETAIL

BID NUMBER

 18982 

NOTE: THIS DRAWING IS SUBJECT TO CHANGE PENDING ROAD RESCUE PRODUCTION ENGINEERING APPROVAL. © ROAD RESCUE ALL RIGHTS RESERVED.



POLK CITY FIRE DEPARTMENT F-550 ULTRAMEDIC // PASS-THROUGH



BLACK POLYURETHANE COATED

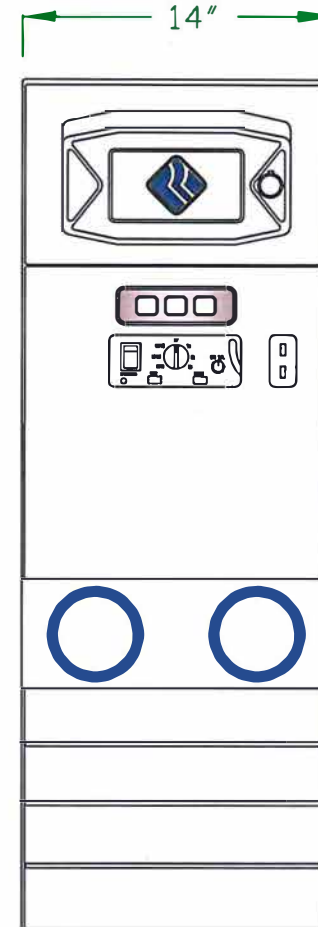
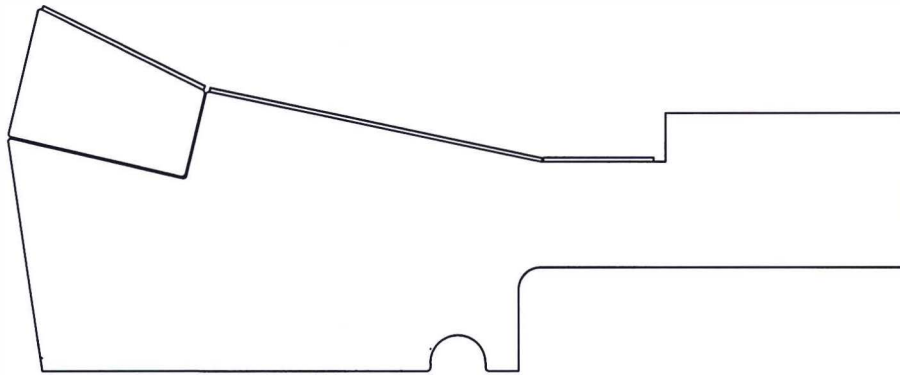

LIGHTED CUP HOLDERS

DETAILS ARE CONCEPTUAL ONLY. LAYOUT AND ALL DIMENSIONS ARE APPROXIMATE AND SUBJECT TO MODIFICATION BY DESIGN ENGINEERING.

PROPRIETARY AND CONFIDENTIAL
THIS INFORMATION CONTAINED IN THIS DRAWING IS THE SOLE PROPERTY OF ROAD RESCUE ANY REPRODUCTION IN PART OR AS A WHOLE WITHOUT THE WRITTEN PERMISSION OF ROAD RESCUE IS PROHIBITED.

Road Rescue 2737 N. Forsyth Rd.
Winter Park, FL 32792

www.roadrescue.com PHONE 800-932-7077 FAX 800-513-2688

DRAWN BY RRS DATE REVISION 1

REVISION 2

REVISION 3

SCALE

SHEET OF 10

CONSOLE CONFIGURATION

BID NUMBER



18982



NOTE: THIS DRAWING IS SUBJECT TO CHANGE PENDING ROAD RESCUE, INC. PRODUCTION ENGINEERING APPROVAL. ©ROAD RESCUE, INC. ALL RIGHTS RESERVED.



EVEREST EMERGENCY VEHICLES F-550 4 X 4 ULTRAMEDIC PASS-THROUGH

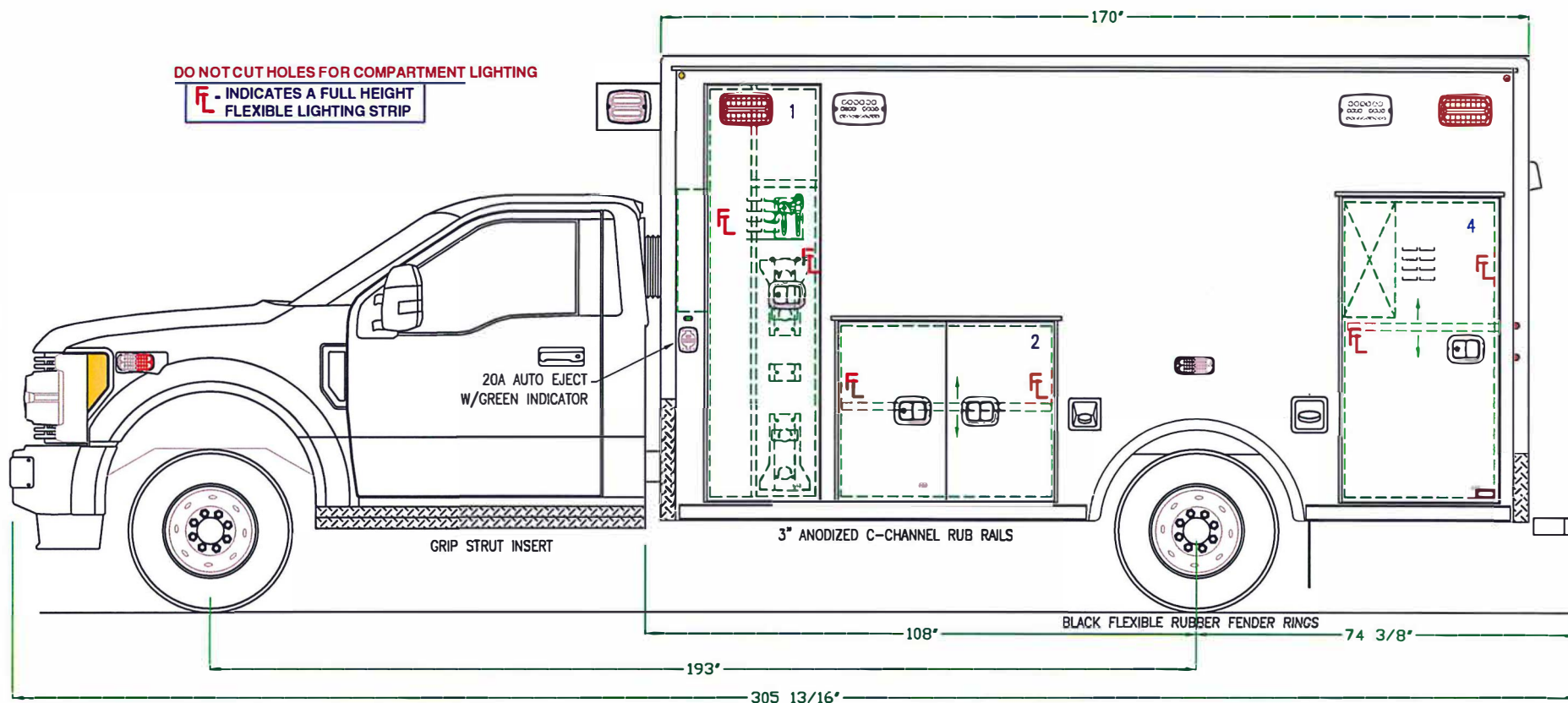

DOOR NO.	INTERIOR DIMENSIONS			NOTES
	HEIGHT	WIDTH	DEPTH	
1	81.50"	23.25"	22.00"	FIXED DIVDER & SHELF, DOOR LOUVERS, O2 STORAGE
2	35.50"	43.88"	21.25"	(1) ADJ. SHELF
4	59.06"	31.50"	21.25"	(1) ADJ. SHELF

NOTES:

DETAILS ARE CONCEPTUAL ONLY.
LAYOUT AND ALL DIMENSIONS ARE APPROXIMATE AND
SUBJECT TO MODIFICATION BY DESIGN ENGINEERING.

PROPRIETARY AND CONFIDENTIAL
THIS INFORMATION CONTAINED IN THIS DRAWING IS THE SOLE PROPERTY OF ROAD RESCUE ANY REPRODUCTION IN PART OR AS A WHOLE WITHOUT THE WRITTEN PERMISSION OF ROAD RESCUE IS PROHIBITED.

Road Rescue
2737 N. FORSYTH RD
WINTER PARK, FL 32792
www.roadrescue.com PHONE 800-932-7077 FAX 800-513-2688

STREETSIDE EXTERIOR DETAIL

BID NUMBER

DRAWN BY: RRS DATE: 05/19/2022 REVISION 1 REVISION 2 REVISION 3 SCALE SHEET 1 OF 10

 **628217** 



EVEREST EMERGENCY VEHICLES F-550 4 X 4 ULTRAMEDIC PASS-THROUGH

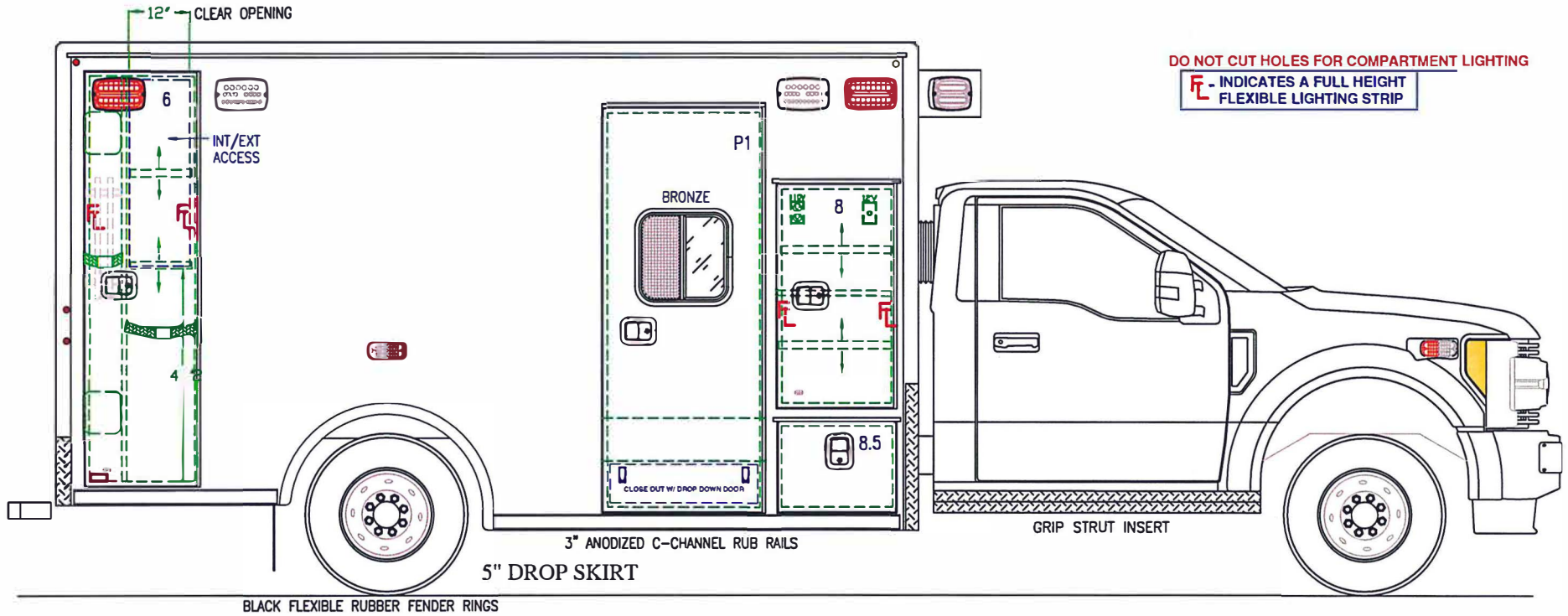

DO NOT CUT HOLES FOR COMPARTMENT LIGHTING

F - INDICATES A FULL HEIGHT FLEXIBLE LIGHTING STRIP

DOOR NO.	INTERIOR DIMENSIONS			NOTES	DOOR NO.	DOOR DIMENSIONS		MISC. NOTES
	HEIGHT	WIDTH	DEPTH			HEIGHT	WIDTH	
6	81.50"	22.75"	22.00"	(1) FIXED DIV., (2) ADJ. SHELVES	8	45.31"	23.00"	RIGHT STACK/ALS ACCESS
8.5	16.00"	23.00"	21.00"	BATTERY DRAWER	P1	73.62"	30.06"	SLIDING BRONZE WINDOW 18" X 18"

DETAILS ARE CONCEPTUAL ONLY. LAYOUT AND ALL DIMENSIONS ARE APPROXIMATE AND SUBJECT TO MODIFICATION BY DESIGN ENGINEERING.

PROPRIETARY AND CONFIDENTIAL. THIS INFORMATION CONTAINED IN THIS DRAWING IS THE SOLE PROPERTY OF ROAD RESCUE ANY REPRODUCTION IN PART OR AS A WHOLE WITHOUT THE WRITTEN PERMISSION OF ROAD RESCUE IS PROHIBITED.

Road Rescue
2737 N. FORSYTH RD
WINTER PARK, FL 32792
www.roadrescue.com PHONE 800-932-7077 FAX 800-513-2688

CURBSIDE EXTERIOR DETAIL

BID NUMBER

628217

DRAWN BY: RRS DATE: 05/19/2022 REVISION 1 REVISION 2 REVISION 3 SCALE: SHEET 2 OF 10

NOTE: THIS DRAWING IS SUBJECT TO CHANGE PENDING ROAD RESCUE, INC. PRODUCTION ENGINEERING APPROVAL. ©ROAD RESCUE, INC. ALL RIGHTS RESERVED.



EVEREST EMERGENCY VEHICLES F-550 4 X 4 ULTRAMEDIC PASS-THROUGH

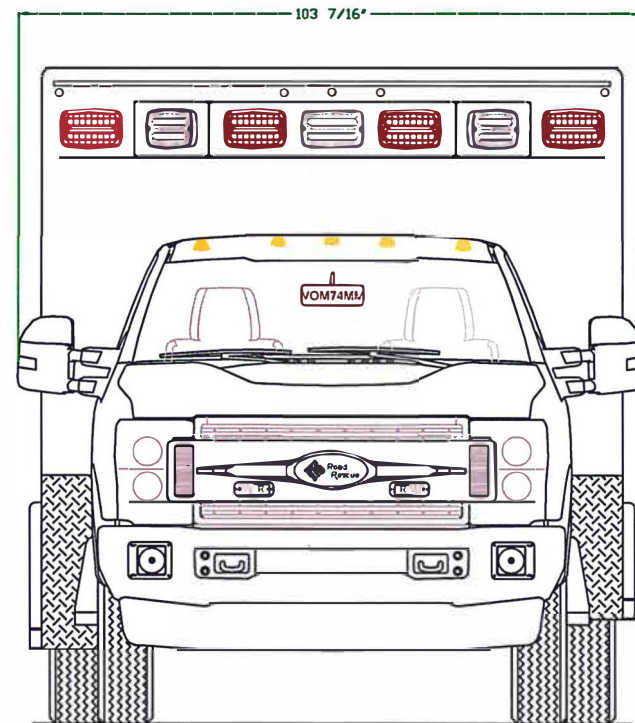
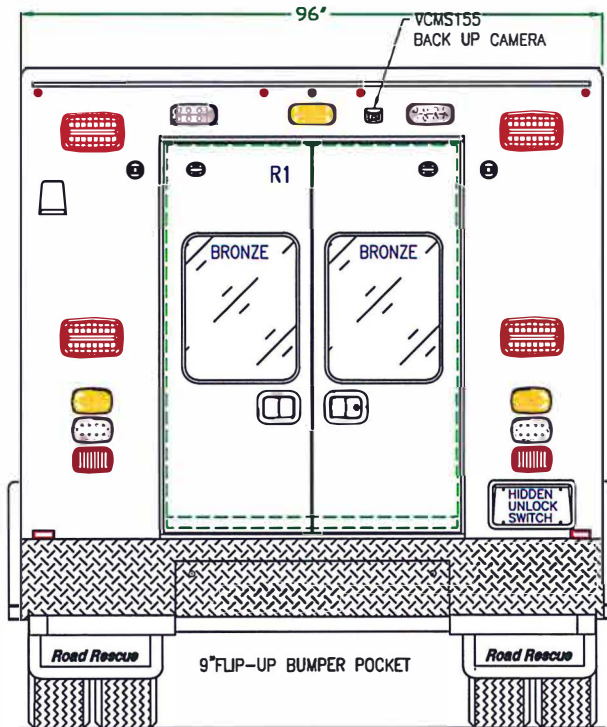

DOOR NO.	CLEAR OPENING		NOTES:
	HEIGHT	WIDTH	
R1	61.44"	50.25"	FIXED BRONZE WINDOWS 18" X 24"

DETAILS ARE CONCEPTUAL ONLY.
LAYOUT AND ALL DIMENSIONS ARE APPROXIMATE AND
SUBJECT TO MODIFICATION BY DESIGN ENGINEERING.

PROPRIETARY AND
CONFIDENTIAL
THIS INFORMATION
CONTAINED IN THIS
DRAWING IS THE SOLE
PROPERTY OF ROAD
RESCUE ANY
REPRODUCTION IN PART
OR AS A WHOLE
WITHOUT THE WRITTEN
PERMISSION OF ROAD
RESCUE IS PROHIBITED.

Road Rescue
2737 N. FORSYTH RD
WINTER PARK, FL 32792
www.roadrescue.com PHONE 800-932-7077 FAX 800-513-2688

FRONT & REAR EXTERIOR DETAIL

BID NUMBER

DRAWN BY: RRS DATE: 05/19/2022 REVISION 1 REVISION 2 REVISION 3 SCALE SHEET 3 OF 10

 **628217** 

NOTE: THIS DRAWING IS SUBJECT TO CHANGE PENDING ROAD RESCUE, INC. PRODUCTION ENGINEERING APPROVAL. ©ROAD RESCUE, INC. ALL RIGHTS RESERVED.



EVEREST EMERGENCY VEHICLES F-550 4 X 4 ULTRAMEDIC PASS-THROUGH

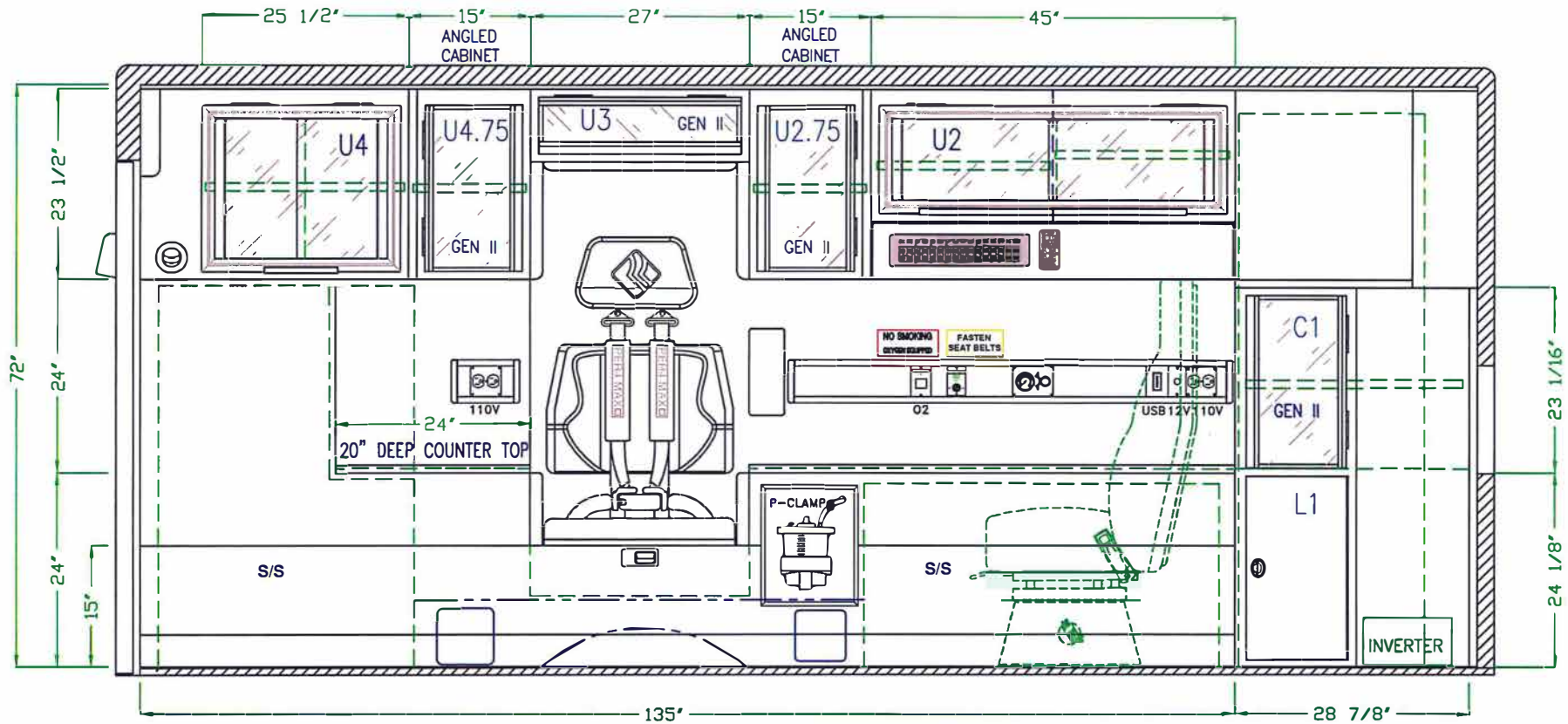

DOOR NO.	INTERIOR DIMENSIONS			NOTES
	HEIGHT	WIDTH	DEPTH	
C1	23.00"	28.50"	16.50"	GEN II OHO DOOR, (1) ADJ. SHELF
L1	23.62"	28.50"	16.50"	SINGLE ALUM. DOOR, LOCKING
U2	23.50"	44.75"	18.12"	SLIDING POLY DOORS, FIXED DIV. (2) ADJ. SHELVES, RESTOCKING
U2.5	16.00"	26.75"	18.12"	GEN II OHO DOOR, RESTOCKING

DOOR NO.	INTERIOR DIMENSIONS			MISC. NOTES
	HEIGHT	WIDTH	DEPTH	
U4	23.50"	25.25"	18.12"	SLIDING POLY DOORS, (1) ADJ. SHELF, RESTOCKING

DETAILS ARE CONCEPTUAL ONLY. LAYOUT AND ALL DIMENSIONS ARE APPROXIMATE AND SUBJECT TO MODIFICATION BY DESIGN ENGINEERING.

PROPRIETARY AND CONFIDENTIAL
THIS INFORMATION CONTAINED IN THIS DRAWING IS THE SOLE PROPERTY OF ROAD RESCUE ANY REPRODUCTION IN PART OR AS A WHOLE WITHOUT THE WRITTEN PERMISSION OF ROAD RESCUE IS PROHIBITED.

Road Rescue
2737 N. FORSYTH RD
WINTER PARK, FL 32792
www.roadrescue.com PHONE 800-932-7077 FAX 800-513-2688

STREETSIDE INTERIOR DETAIL

BID NUMBER

DRAWN BY: RRS DATE: 05/19/2022 REVISION 1 REVISION 2 REVISION 3 SCALE SHEET 4 OF 10

628217

NOTE: THIS DRAWING IS SUBJECT TO CHANGE PENDING ROAD RESCUE, INC. PRODUCTION ENGINEERING APPROVAL. ©ROAD RESCUE, INC. ALL RIGHTS RESERVED.



EVEREST EMERGENCY VEHICLES F-550 4 X 4 ULTRAMEDIC PASS-THROUGH

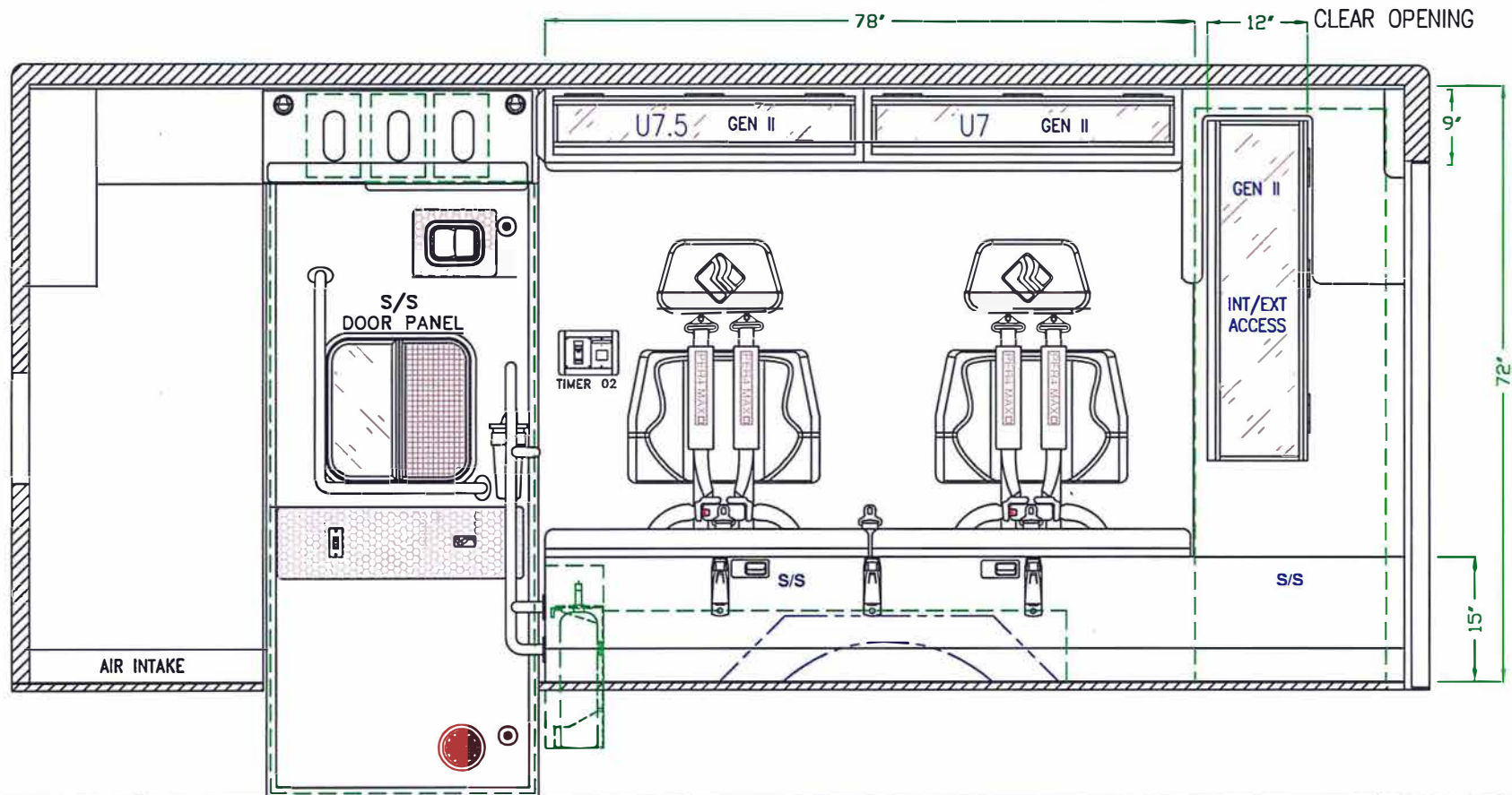

DOOR NO.	INTERIOR DIMENSIONS			NOTES
	HEIGHT	WIDTH	DEPTH	
U7	9.00"	40.00"	8.50"	FLIP UP GEN II DOOR, RESTOCKING
U7.5	9.00"	38.00"	8.50"	FLIP UP GEN II DOOR, RESTOCKING



NOTES:

DETAILS ARE CONCEPTUAL ONLY.
LAYOUT AND ALL DIMENSIONS ARE APPROXIMATE AND SUBJECT TO MODIFICATION BY DESIGN ENGINEERING.

PROPRIETARY AND CONFIDENTIAL
THIS INFORMATION CONTAINED IN THIS DRAWING IS THE SOLE PROPERTY OF ROAD RESCUE ANY REPRODUCTION IN PART OR AS A WHOLE WITHOUT THE WRITTEN PERMISSION OF ROAD RESCUE IS PROHIBITED.

Road Rescue
2737 N. FORSYTH RD
WINTER PARK, FL 32792
www.roadrescue.com PHONE 800-932-7077 FAX 800-513-2688

CURBSIDE INTERIOR DETAIL

BID NUMBER
 628217 

DRAWN BY RRS	DATE 05/19/2022	REVISION 1	REVISION 2	REVISION 3	SCALE	SHEET 5 OF 10
-----------------	--------------------	------------	------------	------------	-------	---------------

NOTE: THIS DRAWING IS SUBJECT TO CHANGE PENDING ROAD RESCUE, INC. PRODUCTION ENGINEERING APPROVAL. © ROAD RESCUE, INC. ALL RIGHTS RESERVED.



EVEREST EMERGENCY VEHICLES F-550 4 X 4 ULTRAMEDIC PASS-THROUGH

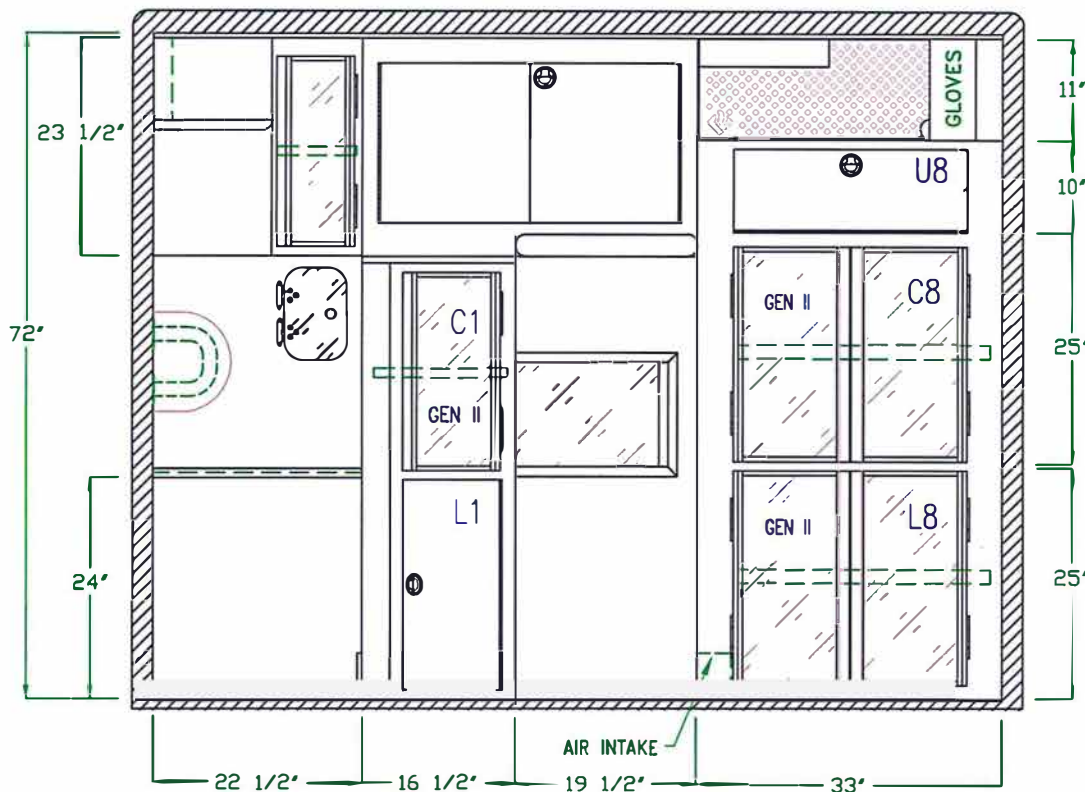

DOOR NO.	INTERIOR DIMENSIONS			NOTES
	HEIGHT	WIDTH	DEPTH	
U8	10.00"	25.00"	26.00"	SINGLE SOLID ALUM, LOCKING LATCH
C8	25.00"	28.00"	26.00"	GEN II OHO DOORS, (1) ADJ. SHELF
L8	25.00"	28.00"	26.00"	GEN II OHO DOORS, (1) ADJ. SHELF

NOTES:

DETAILS ARE CONCEPTUAL ONLY. LAYOUT AND ALL DIMENSIONS ARE APPROXIMATE AND SUBJECT TO MODIFICATION BY DESIGN ENGINEERING.

PROPRIETARY AND CONFIDENTIAL
THIS INFORMATION CONTAINED IN THIS DRAWING IS THE SOLE PROPERTY OF ROAD RESCUE ANY REPRODUCTION IN PART OR AS A WHOLE WITHOUT THE WRITTEN PERMISSION OF ROAD RESCUE IS PROHIBITED.

Road Rescue
2737 N. FORSYTH RD
WINTER PARK, FL 32792
www.roadrescue.com PHONE 800-932-7077 FAX 800-513-2688

FRONT INTERIOR DETAIL

BID NUMBER
628217

DRAWN BY RRS	DATE 05/19/2022	REVISION 1	REVISION 2	REVISION 3	SCALE	SHEET 6 OF 10
-----------------	--------------------	------------	------------	------------	-------	---------------



EVEREST EMERGENCY VEHICLES F-550 4 X 4 ULTRAMEDIC PASS-THROUGH

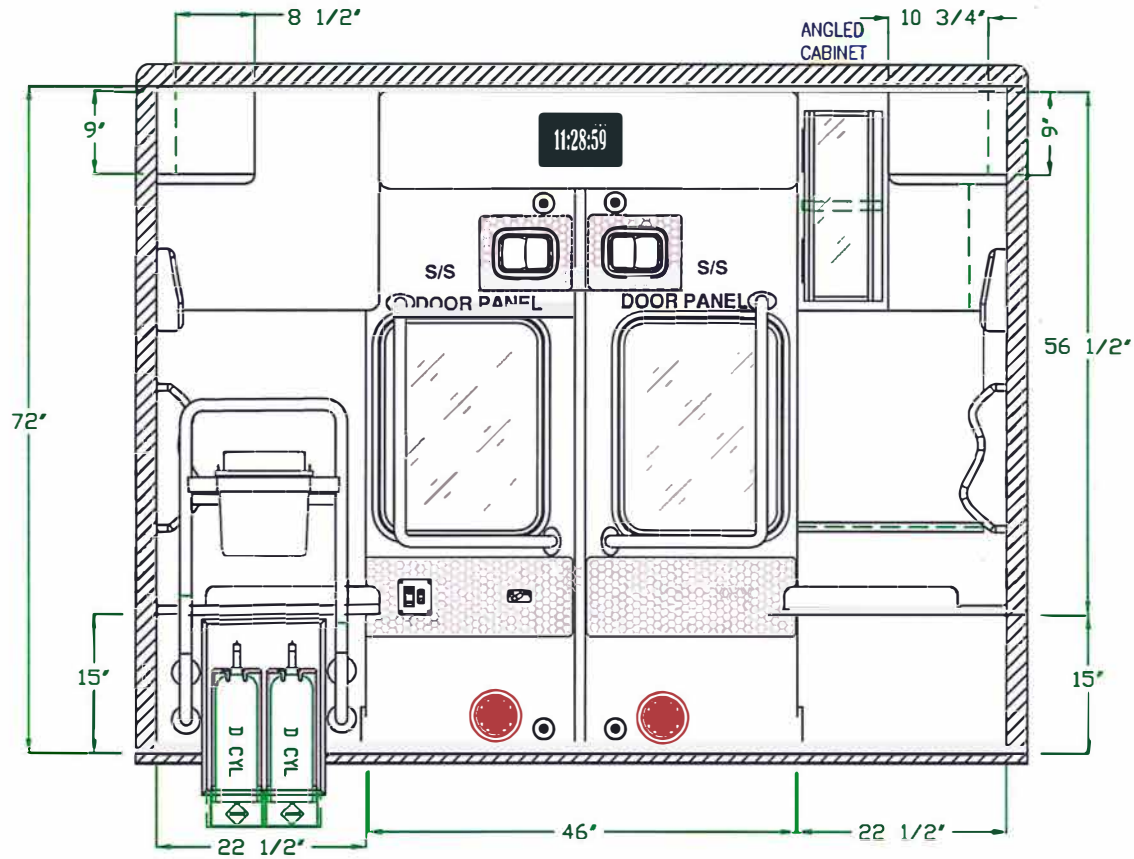

NOTES:

NOTES:

DETAILS ARE CONCEPTUAL ONLY.
LAYOUT AND ALL DIMENSIONS ARE APPROXIMATE AND
SUBJECT TO MODIFICATION BY DESIGN ENGINEERING.

PROPRIETARY AND
CONFIDENTIAL
THIS INFORMATION
CONTAINED IN THIS
DRAWING IS THE SOLE
PROPERTY OF ROAD
RESCUE ANY
REPRODUCTION IN PART
OR AS A WHOLE
WITHOUT THE WRITTEN
PERMISSION OF ROAD
RESCUE IS PROHIBITED.

Road Rescue

2737 N. FORSYTH RD
WINTER PARK, FL 32792

www.roadrescue.com PHONE 800-932-7077 FAX 800-513-2688

REAR INTERIOR DETAIL

BID NUMBER

DRAWN BY RRS	DATE 05/19/2022	REVISION 1	REVISION 2	REVISION 3	SCALE	SHEET 7 OF 10
-----------------	--------------------	------------	------------	------------	-------	---------------

 **628217** 

NOTE: THIS DRAWING IS SUBJECT TO CHANGE PENDING ROAD RESCUE, INC. PRODUCTION ENGINEERING APPROVAL. © ROAD RESCUE, INC. ALL RIGHTS RESERVED.



EVEREST EMERGENCY VEHICLES F-550 4 X 4 ULTRAMEDIC PASS-THROUGH

DEALER SIGNATURE	QVM
------------------	-----

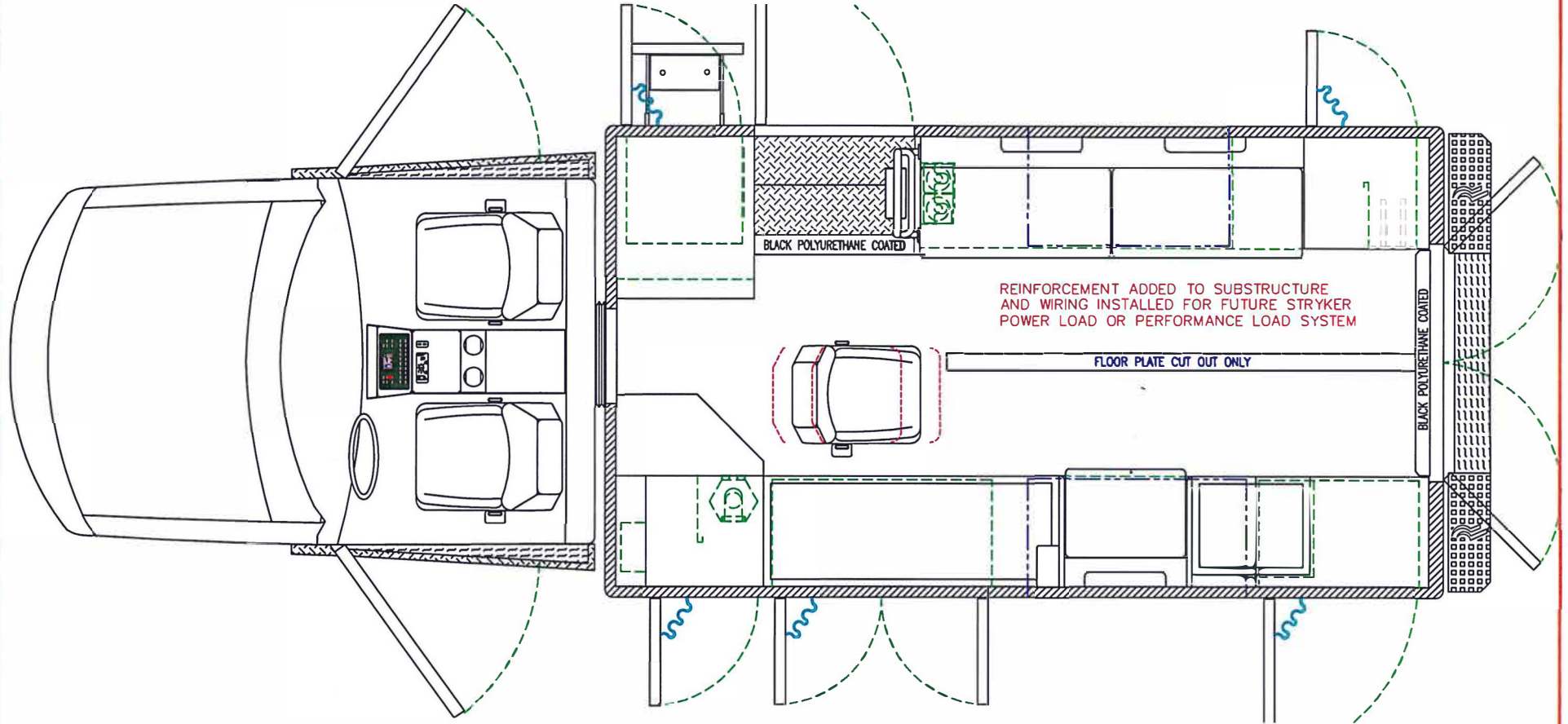

NOTES:

NOTES:

 DETAILS ARE CONCEPTUAL ONLY.
 LAYOUT AND ALL DIMENSIONS ARE APPROXIMATE AND
 SUBJECT TO MODIFICATION BY DESIGN ENGINEERING.

PROPRIETARY AND
 CONFIDENTIAL
 THIS INFORMATION
 CONTAINED IN THIS
 DRAWING IS THE SOLE
 PROPERTY OF ROAD
 RESCUE ANY
 REPRODUCTION IN PART
 OR AS A WHOLE
 WITHOUT THE WRITTEN
 PERMISSION OF ROAD
 RESCUE IS PROHIBITED.

Road Rescue 2737 N. FORSYTH RD
 WINTER PARK, FL 32792
 www.roadrescue.com PHONE 800-932-7077 FAX 800-513-2688

OVERHEAD FLOOR DETAIL

BID NUMBER
628217

DRAWN BY RRS	DATE 05/19/2022	REVISION 1	REVISION 2	REVISION 3	SCALE	SHEET 8 OF 10
-----------------	--------------------	------------	------------	------------	-------	---------------

NOTE: THIS DRAWING IS SUBJECT TO CHANGE PENDING ROAD RESCUE, INC. PRODUCTION ENGINEERING APPROVAL. ©ROAD RESCUE, INC. ALL RIGHTS RESERVED.



EVEREST EMERGENCY VEHICLES F-550 4 X 4 ULTRAMEDIC PASS-THROUGH

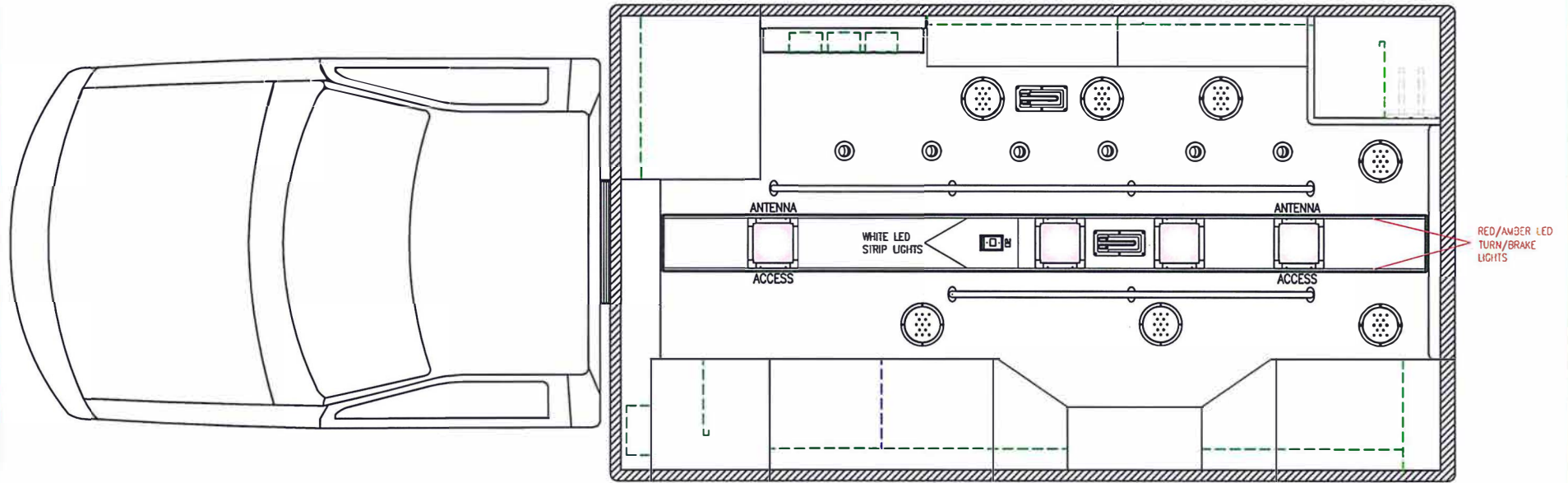

WHITE PVC HEADLINER

NOTES:

NOTES:

DETAILS ARE CONCEPTUAL ONLY.
LAYOUT AND ALL DIMENSIONS ARE APPROXIMATE AND
SUBJECT TO MODIFICATION BY DESIGN ENGINEERING.

PROPRIETARY AND
CONFIDENTIAL
THIS INFORMATION
CONTAINED IN THIS
DRAWING IS THE SOLE
PROPERTY OF ROAD
RESCUE ANY
REPRODUCTION IN PART
OR AS A WHOLE
WITHOUT THE WRITTEN
PERMISSION OF ROAD
RESCUE IS PROHIBITED.

Road Rescue

2737 N. FORSYTH RD
WINTER PARK, FL 32792

www.roadrescue.com PHONE 800-932-7077 FAX 800-513-2688

DRAWN BY RRS DATE 05/19/2022 REVISION 1

REVISION 2

REVISION 3

SCALE

SHEET 9 OF 10

OVERHEAD CEILING DETAIL

BID NUMBER

 628217 

NOTE: THIS DRAWING IS SUBJECT TO CHANGE PENDING ROAD RESCUE, INC. PRODUCTION ENGINEERING APPROVAL. ©ROAD RESCUE, INC. ALL RIGHTS RESERVED.

EVEREST EMERGENCY VEHICLES F-550 4 X 4 ULTRAMEDIC PASS-THROUGH



BLACK POLYURETHANE COATED

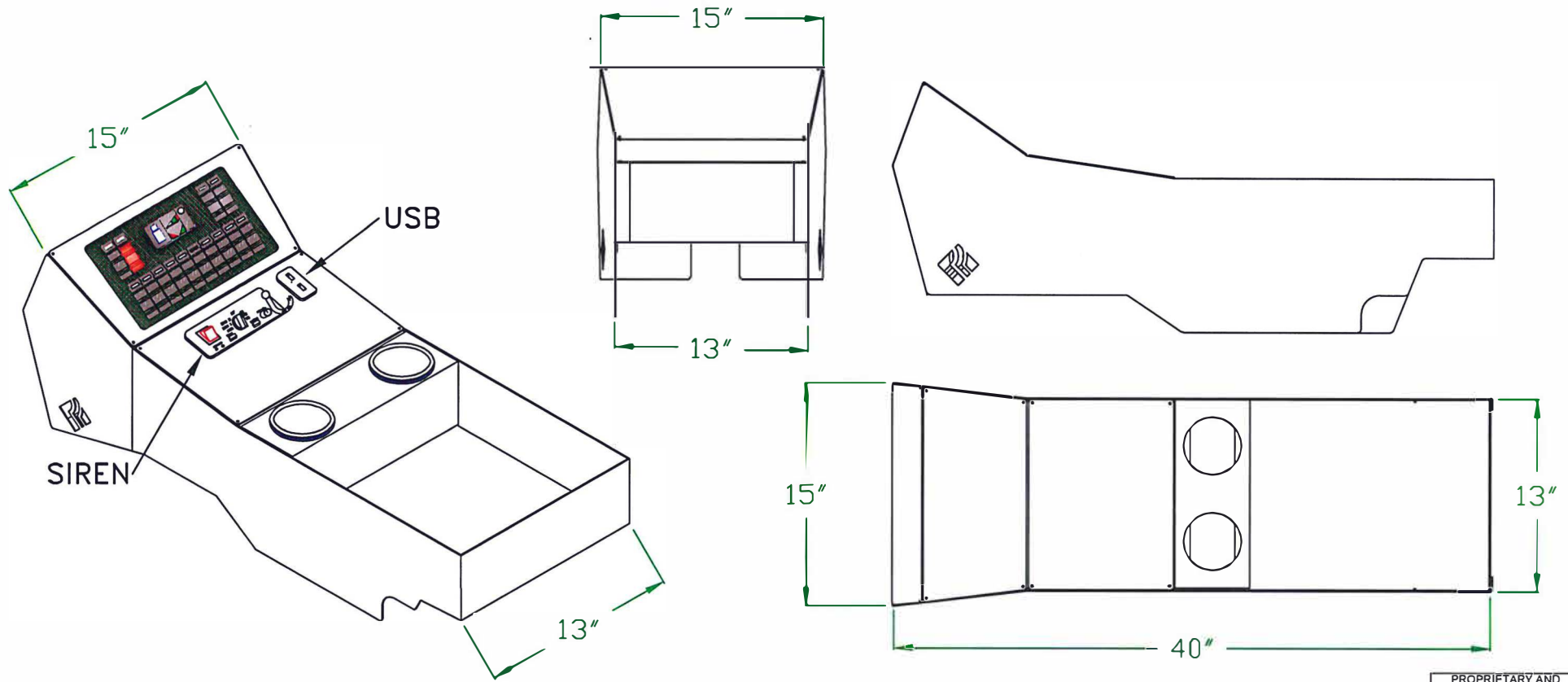

DETAILS ARE CONCEPTUAL ONLY. LAYOUT AND ALL DIMENSIONS ARE APPROXIMATE AND SUBJECT TO MODIFICATION BY DESIGN ENGINEERING.

PROPRIETARY AND CONFIDENTIAL
 THIS INFORMATION CONTAINED IN THIS DRAWING IS THE SOLE PROPERTY OF ROAD RESCUE ANY REPRODUCTION IN PART OR AS A WHOLE WITHOUT THE WRITTEN PERMISSION OF ROAD RESCUE IS PROHIBITED.

Road Rescue, Inc. 2737 N. Forsyth Rd.
 Winterpark, FL 32892
 www.roadrescue.com PHONE 800-932-7077 FAX 800-513-2688

CONSOLE CONFIGURATION

BID NUMBER

DRAWN BY	DATE	REVISION 1	REVISION 2	REVISION 3	SCALE	SHEET 10 OF 10
----------	------	------------	------------	------------	-------	----------------

628217



EVEREST EMERGENCY VEHICLES F-550 4 X 4 ULTRAMEDIC PASS-THROUGH

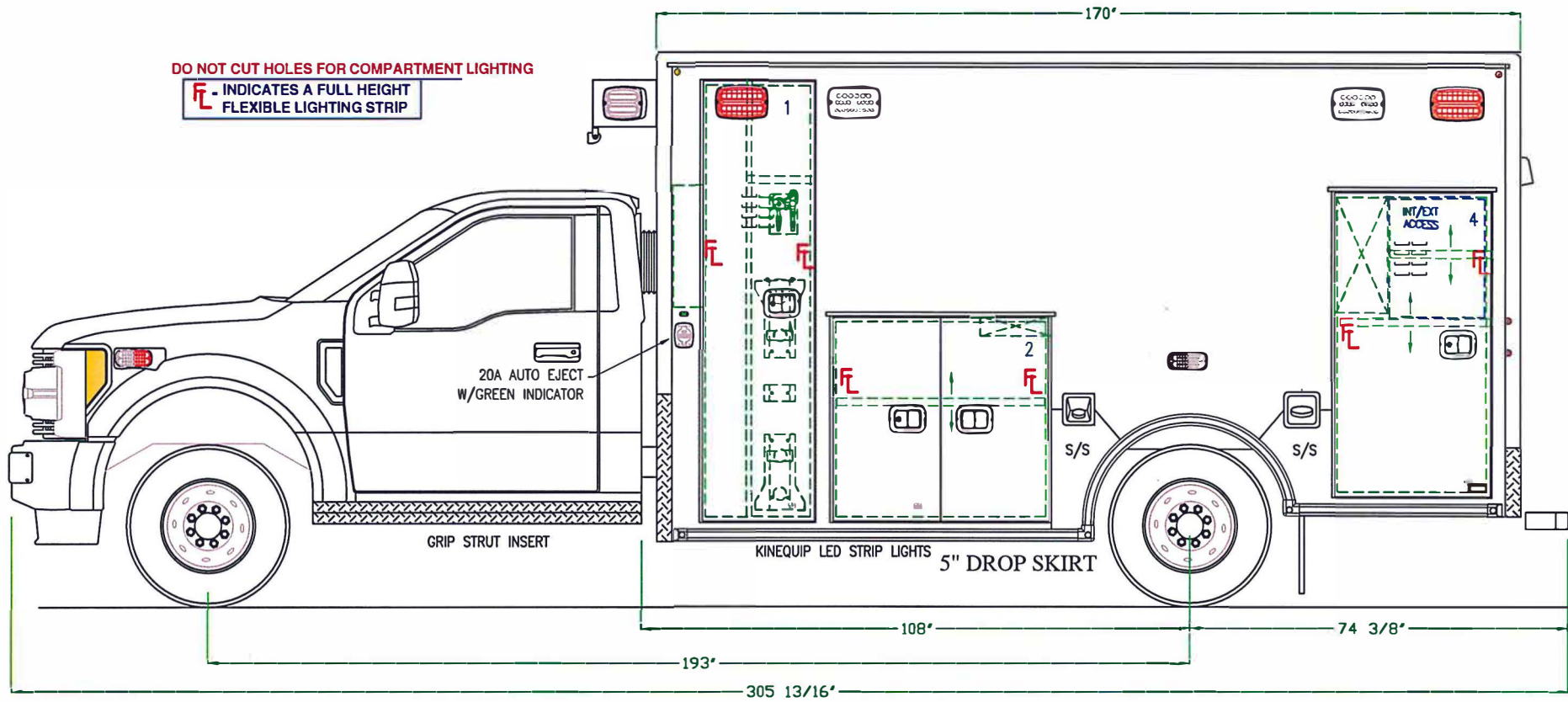

DOOR NO.	INTERIOR DIMENSIONS			NOTES
	HEIGHT	WIDTH	DEPTH	
1	86.50"	23.25"	22.00"	FIXED DIVDER & SHELF, DOOR LOUVERS, O2 STORAGE
2	40.50"	43.88"	21.25"	(1) ADJ. SHELF
4	59.06"	31.50"	21.25"	(1) ADJ. SHELF

NOTES:

DETAILS ARE CONCEPTUAL ONLY. LAYOUT AND ALL DIMENSIONS ARE APPROXIMATE AND SUBJECT TO MODIFICATION BY DESIGN ENGINEERING.

PROPRIETARY AND CONFIDENTIAL
THIS INFORMATION CONTAINED IN THIS DRAWING IS THE SOLE PROPERTY OF ROAD RESCUE ANY REPRODUCTION IN PART OR AS A WHOLE WITHOUT THE WRITTEN PERMISSION OF ROAD RESCUE IS PROHIBITED.

Road Rescue 2737 N. FORSYTH RD
WINTER PARK, FL 32792
www.roadrescue.com PHONE 800-932-7077 FAX 800-513-2688

STREETSIDE EXTERIOR DETAIL

BID NUMBER

DRAWN BY: GDG DATE: 11/01/2022 REVISION 1 REVISION 2 REVISION 3 SCALE: SHEET 1 OF 10

641110



EVEREST EMERGENCY VEHICLES F-550 4 X 4 ULTRAMEDIC PASS-THROUGH

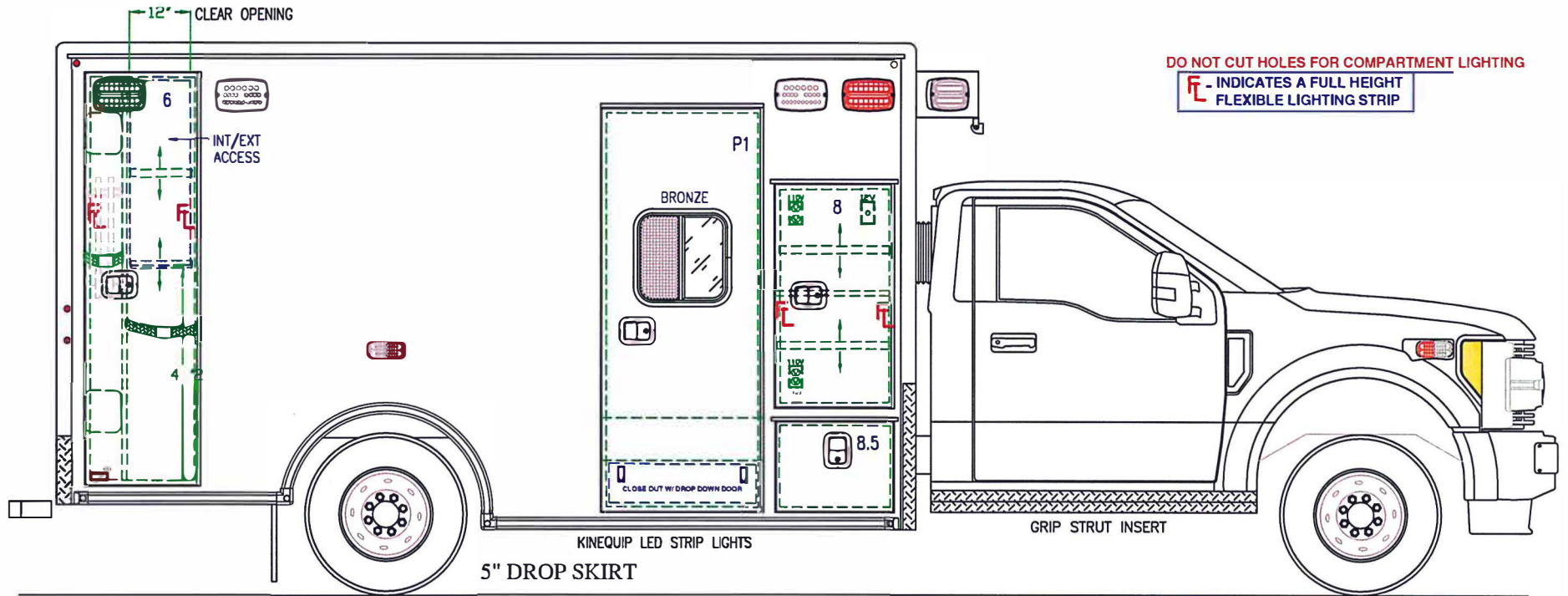

DOOR NO.	INTERIOR DIMENSIONS			NOTES	DOOR NO.	DOOR DIMENSIONS		MISC. NOTES
	HEIGHT	WIDTH	DEPTH			HEIGHT	WIDTH	
6	81.50"	22.75"	22.00"	(1) FIXED DIV., (2) ADJ. SHELVES	8	45.31"	23.00"	RIGHT STACK/ALS ACCESS
8.5	16.00"	23.00"	21.00"	BATTERY DRAWER	P1	73.62"	30.06"	SLIDING BRONZE WINDOW 18" X 18"

DETAILS ARE CONCEPTUAL ONLY. LAYOUT AND ALL DIMENSIONS ARE APPROXIMATE AND SUBJECT TO MODIFICATION BY DESIGN ENGINEERING.

PROPRIETARY AND CONFIDENTIAL. THIS INFORMATION CONTAINED IN THIS DRAWING IS THE SOLE PROPERTY OF ROAD RESCUE ANY REPRODUCTION IN PART OR AS A WHOLE WITHOUT THE WRITTEN PERMISSION OF ROAD RESCUE IS PROHIBITED.

Road Rescue
2737 N. FORSYTH RD
WINTER PARK, FL 32792
www.roadrescue.com PHONE 800-932-7077 FAX 800-513-2688

CURBSIDE EXTERIOR DETAIL

BID NUMBER
641110

DRAWN BY: GDG DATE: 11/01/2022 REVISION 1 REVISION 2 REVISION 3 SCALE SHEET 2 OF 10



EVEREST EMERGENCY VEHICLES F-550 4 X 4 ULTRAMEDIC PASS-THROUGH

DEALER SIGNATURE 

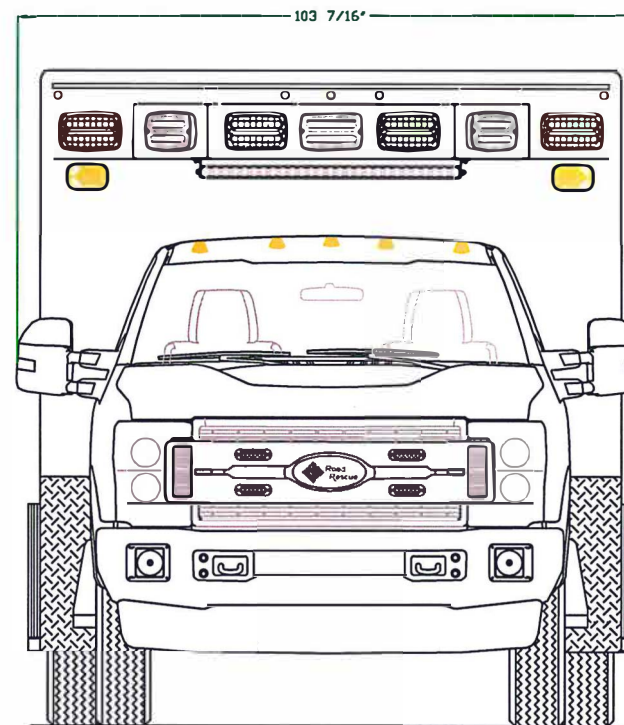
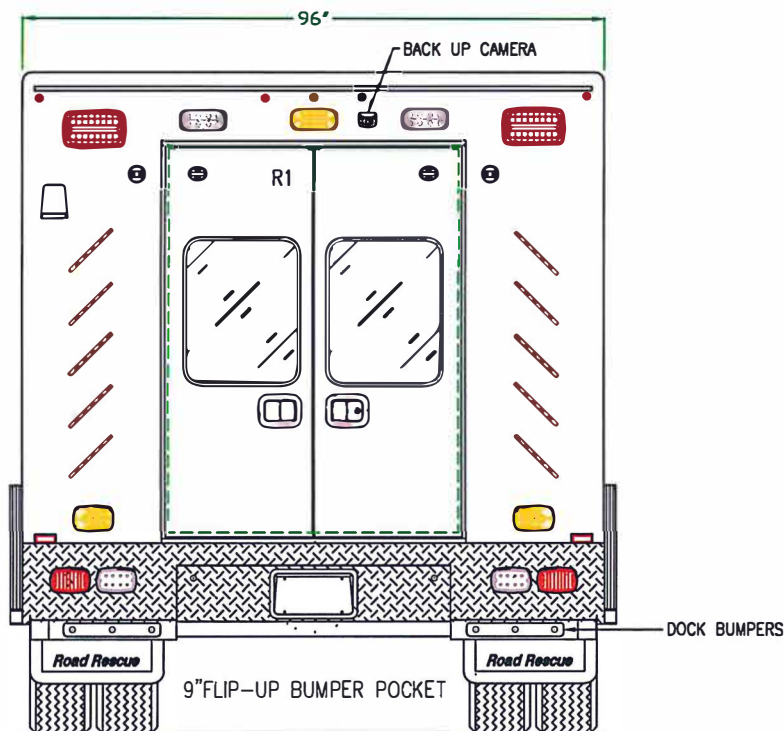

DOOR NO.	CLEAR OPENING		NOTES:
	HEIGHT	WIDTH	
R1	61.44"	50.25"	FIXED BRONZE WINDOWS 18" X 24"

DETAILS ARE CONCEPTUAL ONLY.
LAYOUT AND ALL DIMENSIONS ARE APPROXIMATE AND
SUBJECT TO MODIFICATION BY DESIGN ENGINEERING.

PROPRIETARY AND CONFIDENTIAL
THIS INFORMATION CONTAINED IN THIS DRAWING IS THE SOLE PROPERTY OF ROAD RESCUE ANY REPRODUCTION IN PART OR AS A WHOLE WITHOUT THE WRITTEN PERMISSION OF ROAD RESCUE IS PROHIBITED.

Road Rescue 2737 N. FORSYTH RD
WINTER PARK, FL 32792
www.roadrescue.com PHONE 800-932-7077 FAX 800-513-2688

FRONT & REAR EXTERIOR DETAIL

BID NUMBER  641110 

DRAWN BY: GDG DATE: 11/01/2022 REVISION 1 REVISION 2 REVISION 3 SCALE: SHEET 3 OF 10

NOTE: THIS DRAWING IS SUBJECT TO CHANGE PENDING ROAD RESCUE, INC. PRODUCTION ENGINEERING APPROVAL. ©ROAD RESCUE, INC. ALL RIGHTS RESERVED.



EVEREST EMERGENCY VEHICLES F-550 4 X 4 ULTRAMEDIC PASS-THROUGH

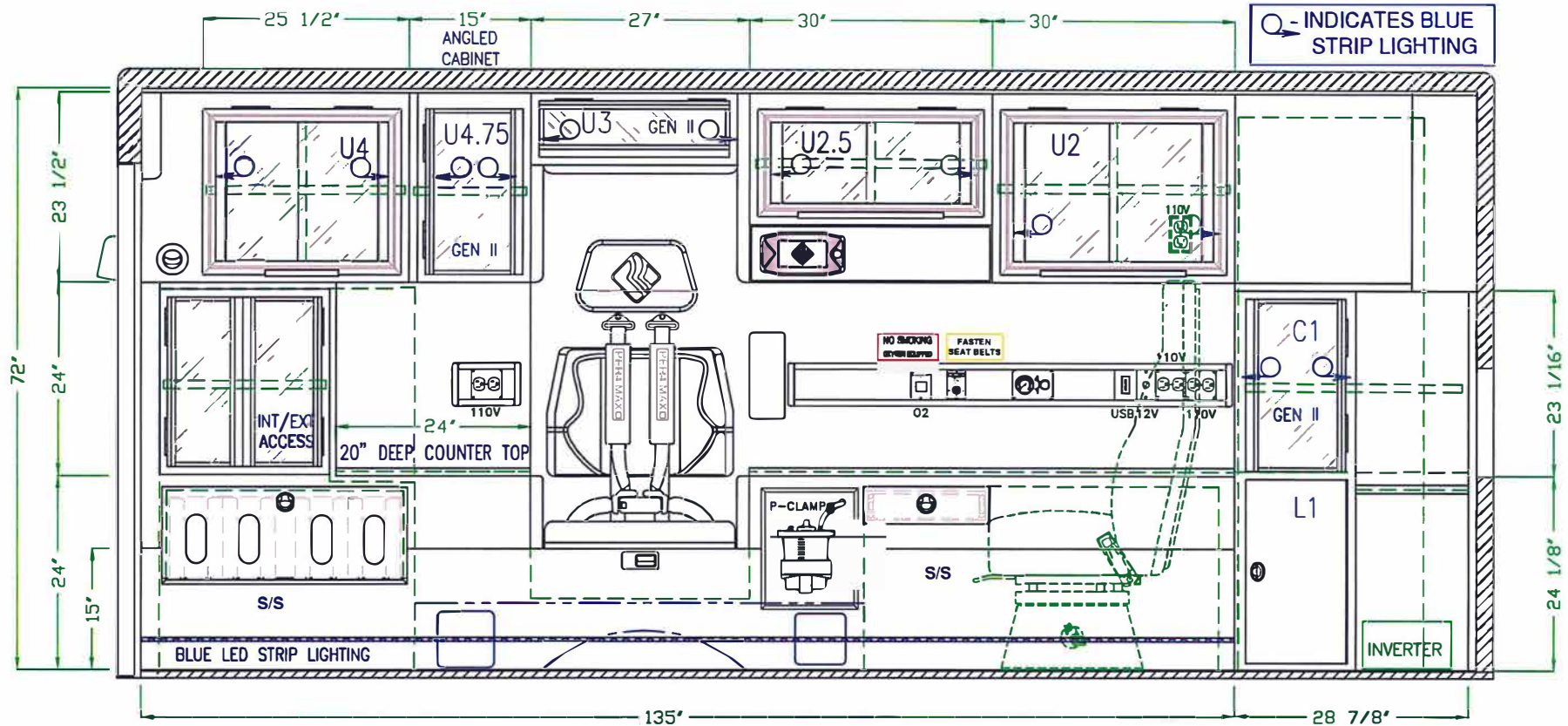

DOOR NO.	INTERIOR DIMENSIONS			NOTES
	HEIGHT	WIDTH	DEPTH	
C1	23.00"	28.50"	16.50"	GEN II OHO DOOR, (1) ADJ. SHELF
L1	23.62"	28.50"	16.50"	SINGLE ALUM. DOOR, LOCKING
U2	23.50"	29.75"	18.12"	SLIDING POLY DOORS, (1) ADJ. SHELF, RESTOCKING
U2.5	16.00"	29.75"	18.12"	SLIDING POLY DOORS, (1) ADJ. SHELF, RESTOCKING

DOOR NO.	INTERIOR DIMENSIONS			MISC. NOTES
	HEIGHT	WIDTH	DEPTH	
U4	23.50"	25.25"	18.12"	SLIDING POLY DOORS, (1) ADJ. SHELF, RESTOCKING

DETAILS ARE CONCEPTUAL ONLY.
LAYOUT AND ALL DIMENSIONS ARE APPROXIMATE AND SUBJECT TO MODIFICATION BY DESIGN ENGINEERING.

PROPRIETARY AND CONFIDENTIAL
THIS INFORMATION CONTAINED IN THIS DRAWING IS THE SOLE PROPERTY OF ROAD RESCUE ANY REPRODUCTION IN PART OR AS A WHOLE WITHOUT THE WRITTEN PERMISSION OF ROAD RESCUE IS PROHIBITED.

Road Rescue 2737 N. FORSYTH RD WINTER PARK, FL 32792

www.roadrescue.com PHONE 800-932-7077 FAX 800-513-2688

DRAWN BY: GDG DATE: 11/01/2022 REVISION 1

STREETSIDE INTERIOR DETAIL

REVISION 2 REVISION 3 SCALE SHEET 4 OF 10

BID NUMBER

641110



EVEREST EMERGENCY VEHICLES F-550 4 X 4 ULTRAMEDIC PASS-THROUGH

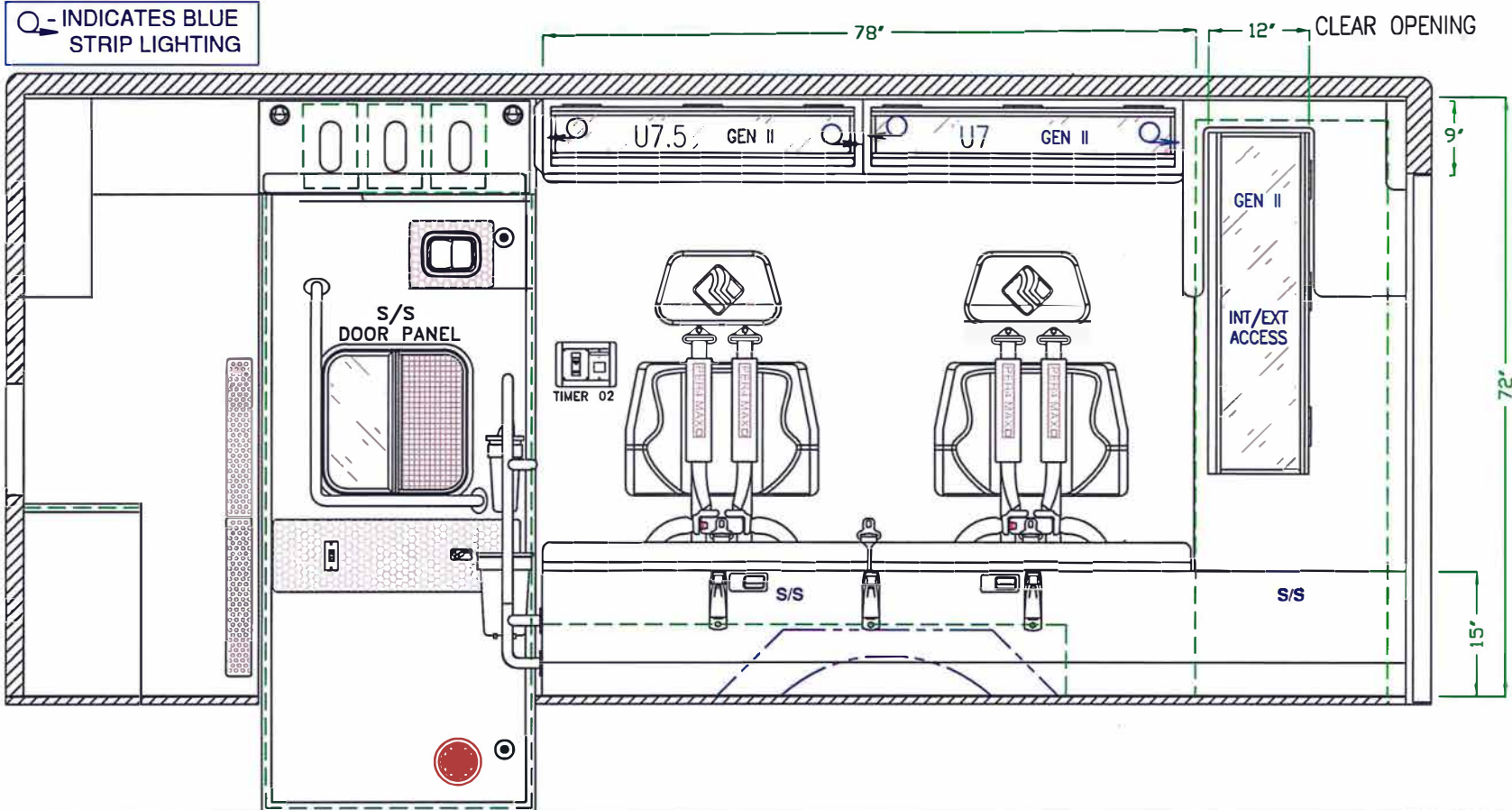

DOOR NO.	INTERIOR DIMENSIONS			NOTES
	HEIGHT	WIDTH	DEPTH	
U7	9.00"	40.00"	8.50"	FLIP UP GEN II DOOR, RESTOCKING
U7.5	9.00"	38.00"	8.50"	FLIP UP GEN II DOOR, RESTOCKING

NOTES:
 DETAILS ARE CONCEPTUAL ONLY.
 LAYOUT AND ALL DIMENSIONS ARE APPROXIMATE AND
 SUBJECT TO MODIFICATION BY DESIGN ENGINEERING.

PROPRIETARY AND CONFIDENTIAL
 THIS INFORMATION CONTAINED IN THIS DRAWING IS THE SOLE PROPERTY OF ROAD RESCUE ANY REPRODUCTION IN PART OR AS A WHOLE WITHOUT THE WRITTEN PERMISSION OF ROAD RESCUE IS PROHIBITED.

Road Rescue
 2737 N. FORSYTH RD
 WINTER PARK, FL 32792
 www.roadrescue.com PHONE 800-932-7077 FAX 800-513-2688

CURBSIDE INTERIOR DETAIL

BID NUMBER

DRAWN BY GDG	DATE 11/01/2022	REVISION 1	REVISION 2	REVISION 3	SCALE	SHEET 5 OF 10
-----------------	--------------------	------------	------------	------------	-------	---------------

641110



EVEREST EMERGENCY VEHICLES F-550 4 X 4 ULTRAMEDIC PASS-THROUGH

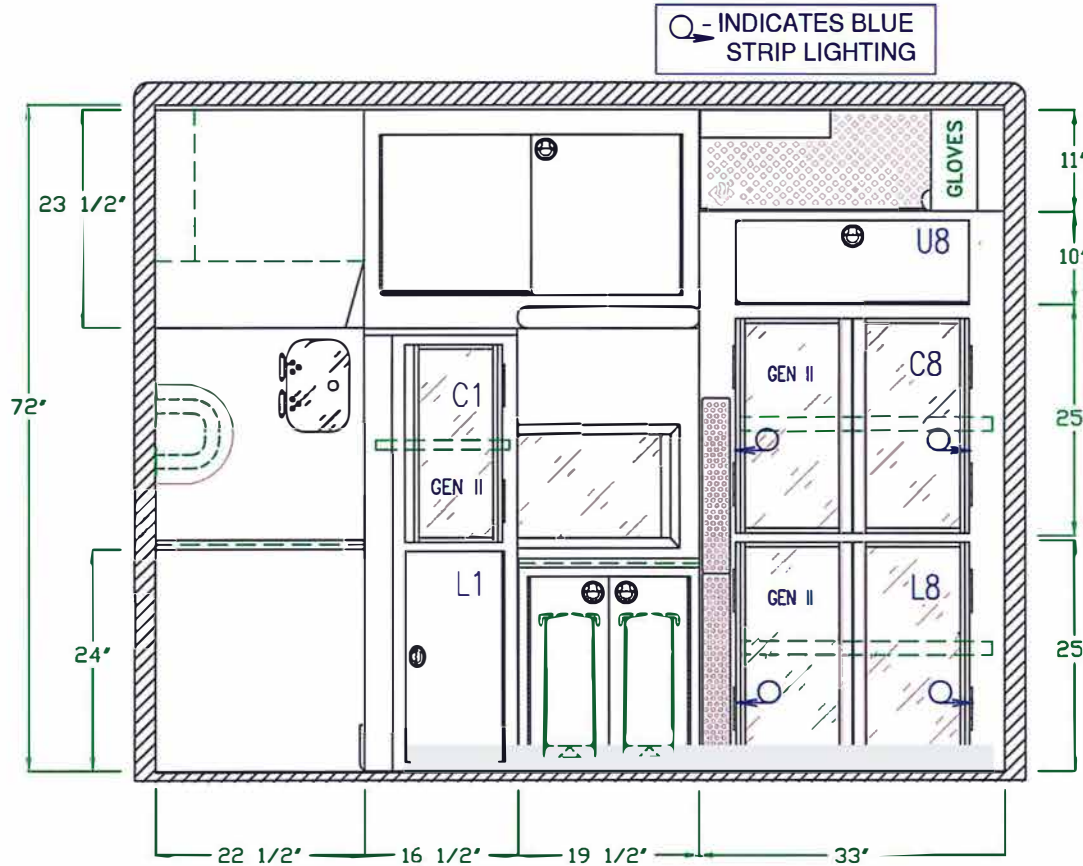

DOOR NO.	INTERIOR DIMENSIONS			NOTES
	HEIGHT	WIDTH	DEPTH	
U8	10.00"	25.00"	26.00"	SINGLE SOLID ALUM, LOCKING LATCH
C8	25.00"	28.00"	26.00"	GEN II OHO DOORS, (1) ADJ. SHELF
L8	25.00"	28.00"	26.00"	GEN II OHO DOORS, (1) ADJ. SHELF

NOTES:
 DETAILS ARE CONCEPTUAL ONLY.
 LAYOUT AND ALL DIMENSIONS ARE APPROXIMATE AND
 SUBJECT TO MODIFICATION BY DESIGN ENGINEERING.

PROPRIETARY AND CONFIDENTIAL
 THIS INFORMATION CONTAINED IN THIS DRAWING IS THE SOLE PROPERTY OF ROAD RESCUE ANY REPRODUCTION IN PART OR AS A WHOLE WITHOUT THE WRITTEN PERMISSION OF ROAD RESCUE IS PROHIBITED.

Road Rescue 2737 N. FORSYTH RD
 WINTER PARK, FL 32792
 www.roadrescue.com PHONE 800-932-7077 FAX 800-513-2688
 DRAWN BY: GDG DATE: 11/01/2022 REVISION 1

FRONT INTERIOR DETAIL

BID NUMBER
 641110

NOTE: THIS DRAWING IS SUBJECT TO CHANGE PENDING ROAD RESCUE, INC. PRODUCTION ENGINEERING APPROVAL. ©ROAD RESCUE, INC. ALL RIGHTS RESERVED.



EVEREST EMERGENCY VEHICLES F-550 4 X 4 ULTRAMEDIC PASS-THROUGH

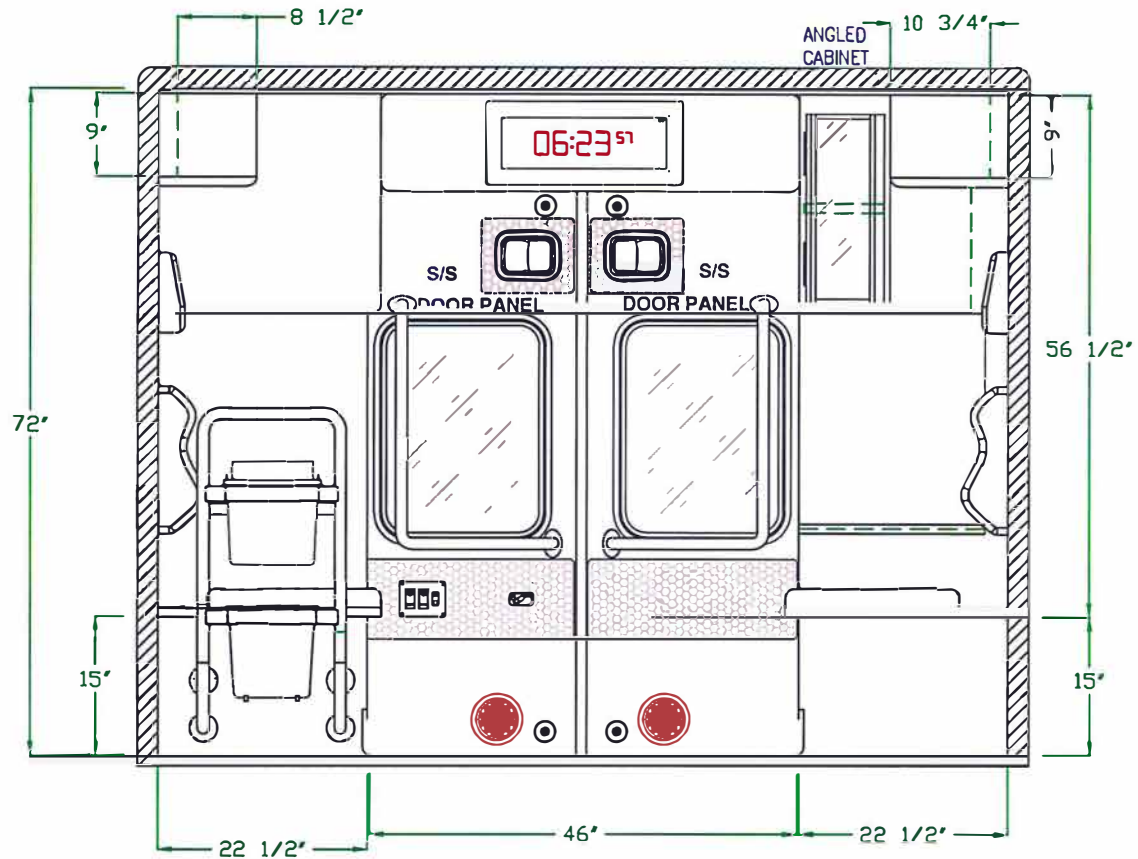

NOTES:

NOTES:

DETAILS ARE CONCEPTUAL ONLY.
LAYOUT AND ALL DIMENSIONS ARE APPROXIMATE AND
SUBJECT TO MODIFICATION BY DESIGN ENGINEERING.

PROPRIETARY AND
CONFIDENTIAL
THIS INFORMATION
CONTAINED IN THIS
DRAWING IS THE SOLE
PROPERTY OF ROAD
RESCUE ANY
REPRODUCTION IN PART
OR AS A WHOLE
WITHOUT THE WRITTEN
PERMISSION OF ROAD
RESCUE IS PROHIBITED.

Road Rescue

2737 N. FORSYTH RD
WINTER PARK, FL 32792

www.roadrescue.com PHONE 800-932-7077 FAX 800-513-2688

DRAWN BY: GDG DATE: 11/01/2022 REVISION 1

REVISION 2

REVISION 3

SCALE

SHEET 7 OF 10

REAR INTERIOR DETAIL

BID NUMBER

641110

NOTE: THIS DRAWING IS SUBJECT TO CHANGE PENDING ROAD RESCUE, INC. PRODUCTION ENGINEERING APPROVAL. ©ROAD RESCUE, INC. ALL RIGHTS RESERVED.



EVEREST EMERGENCY VEHICLES F-550 4 X 4 ULTRAMEDIC PASS-THROUGH

DEALER SIGNATURE 

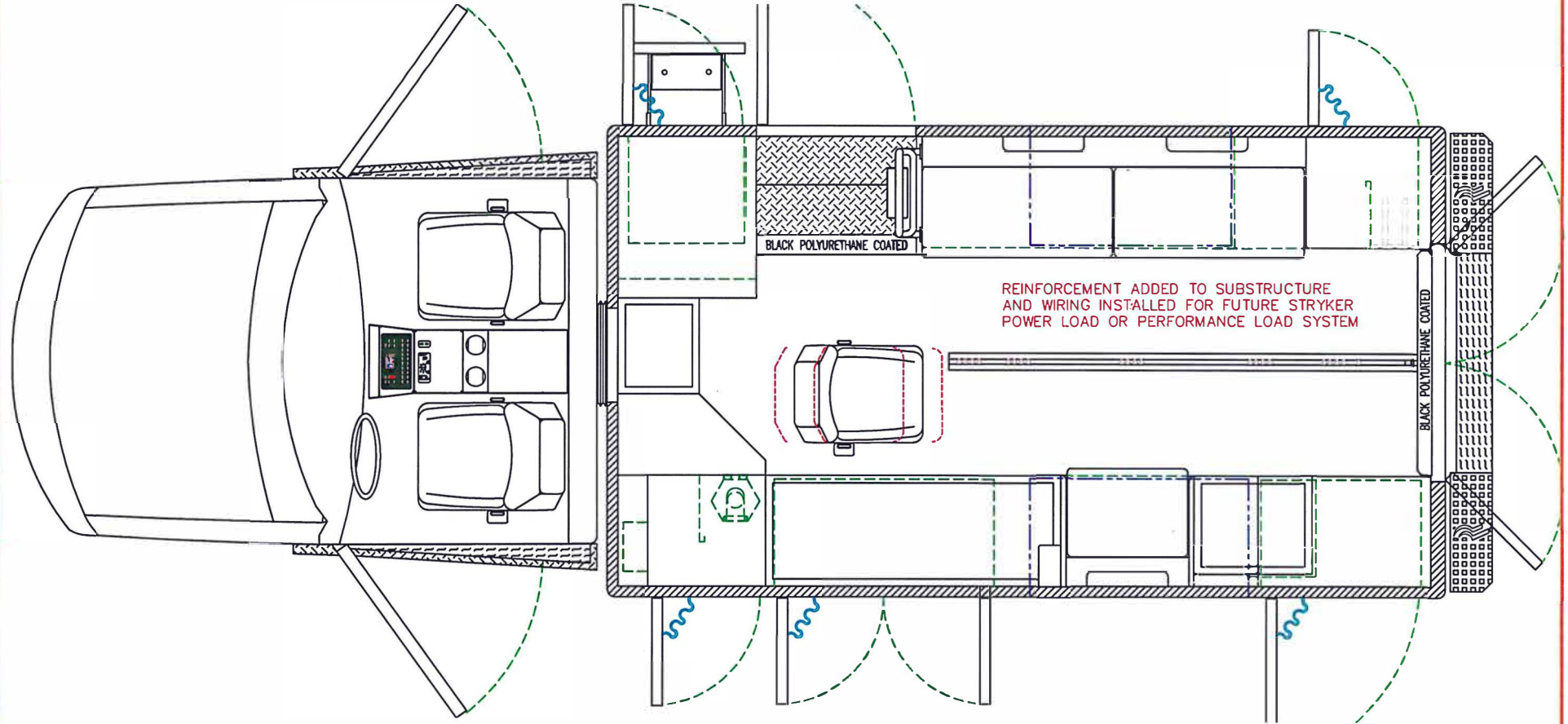

NOTES:



NOTES:

DETAILS ARE CONCEPTUAL ONLY.
LAYOUT AND ALL DIMENSIONS ARE APPROXIMATE AND
SUBJECT TO MODIFICATION BY DESIGN ENGINEERING.

PROPRIETARY AND
CONFIDENTIAL
THIS INFORMATION
CONTAINED IN THIS
DRAWING IS THE SOLE
PROPERTY OF ROAD
RESCUE ANY
REPRODUCTION IN PART
OR AS A WHOLE
WITHOUT THE WRITTEN
PERMISSION OF ROAD
RESCUE IS PROHIBITED.

Road Rescue 2737 N. FORSYTH RD
WINTER PARK, FL 32792
www.roadrescue.com PHONE 800-932-7077 FAX 800-513-2688

OVERHEAD FLOOR DETAIL

BID NUMBER
 641110 

DRAWN BY GDG	DATE 11/01/2022	REVISION 1	REVISION 2	REVISION 3	SCALE	SHEET 8 OF 10
-----------------	--------------------	------------	------------	------------	-------	---------------



EVEREST EMERGENCY VEHICLES F-550 4 X 4 ULTRAMEDIC PASS-THROUGH

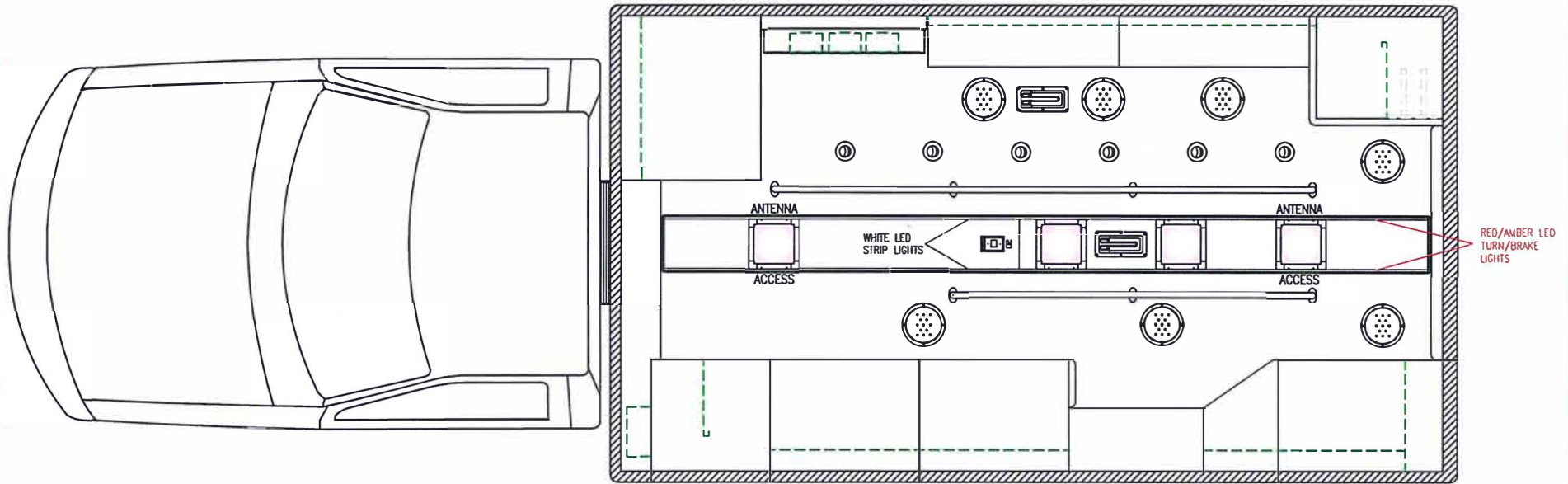

WHITE PVC HEADLINER

NOTES:

NOTES:
 DETAILS ARE CONCEPTUAL ONLY.
 LAYOUT AND ALL DIMENSIONS ARE APPROXIMATE AND
 SUBJECT TO MODIFICATION BY DESIGN ENGINEERING.

PROPRIETARY AND
 CONFIDENTIAL
 THIS INFORMATION
 CONTAINED IN THIS
 DRAWING IS THE SOLE
 PROPERTY OF ROAD
 RESCUE ANY
 REPRODUCTION IN PART
 OR AS A WHOLE
 WITHOUT THE WRITTEN
 PERMISSION OF ROAD
 RESCUE IS PROHIBITED.

Road Rescue 2737 N. FORSYTH RD
 WINTER PARK, FL 32792
 www.roadrescue.com PHONE 800-932-7077 FAX 800-513-2688

OVERHEAD CEILING DETAIL

BID NUMBER
 641110

DRAWN BY GDG	DATE 11/01/2022	REVISION 1	REVISION 2	REVISION 3	SCALE	SHEET 9 OF 10
-----------------	--------------------	------------	------------	------------	-------	---------------

NOTE: THIS DRAWING IS SUBJECT TO CHANGE PENDING ROAD RESCUE, INC. PRODUCTION ENGINEERING APPROVAL. ©ROAD RESCUE, INC. ALL RIGHTS RESERVED.



EVEREST EMERGENCY VEHICLES F-550 4 X 4 ULTRAMEDIC PASS-THROUGH



BLACK POLYURETHANE COATED

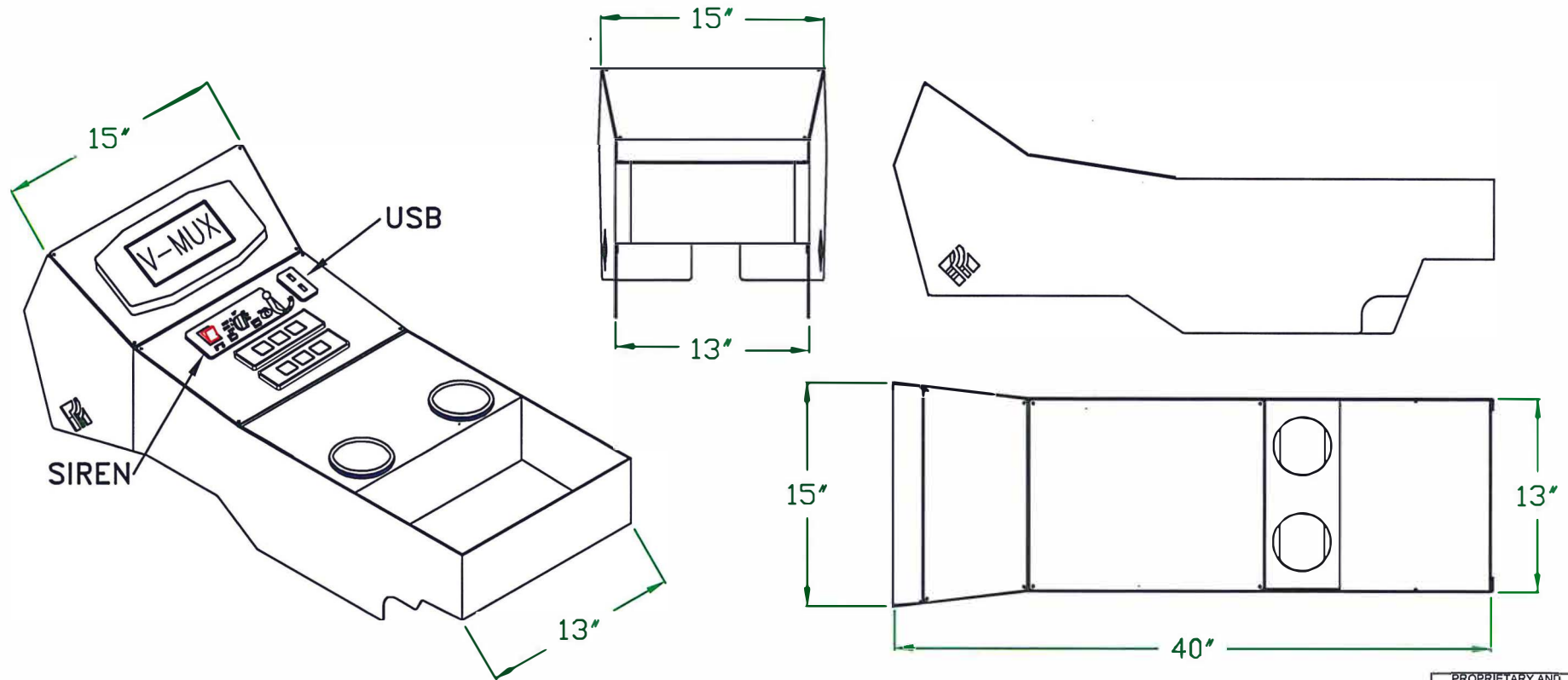

DETAILS ARE CONCEPTUAL ONLY. LAYOUT AND ALL DIMENSIONS ARE APPROXIMATE AND SUBJECT TO MODIFICATION BY DESIGN ENGINEERING.

PROPRIETARY AND CONFIDENTIAL
THIS INFORMATION CONTAINED IN THIS DRAWING IS THE SOLE PROPERTY OF ROAD RESCUE ANY REPRODUCTION IN PART OR AS A WHOLE WITHOUT THE WRITTEN PERMISSION OF ROAD RESCUE IS PROHIBITED.

Road Rescue, Inc. 2737 N. Forsyth Rd., Winterpark, FL 32892

www.roadrescue.com PHONE 800-932-7077 FAX 800-513-2688

CONSOLE CONFIGURATION

BID NUMBER

DRAWN BY	DATE	REVISION 1	REVISION 2	REVISION 3	SCALE	SHEET 10 OF 10
----------	------	------------	------------	------------	-------	----------------

 **641110** 

NOTE: THIS DRAWING IS SUBJECT TO CHANGE PENDING ROAD RESCUE, INC. PRODUCTION ENGINEERING APPROVAL. ©ROAD RESCUE, INC. ALL RIGHTS RESERVED.

Jasper County Jail

January 16, 2022

Copystar 3554 CI B&W/Color Copy, Print, Scan

New

- 35 page per minute print/copy speed
- 100-sheet bypass tray
- (2) 500-sheet universal paper drawers
- Document Feeder
- Numeric Keypad
- Automatic Duplexing
- Print Controller for computer, IPAD, Android Smart Phone or Android touch pad
- B&W/Color scan to computer, IPAD, Android Smart Phone or Android touch pad
- Account Track feature (password copying/printing)
- Includes delivery, initial set-up on print server and ongoing training

Purchase Price: \$5627.00

Optional Service Contract (Monthly)

Gold Level Service Plan: Plan covers Toner, Parts, Supply Kits and Labor. Excludes Acts of God, Water, Theft, Vandalism, Fire and Network related problems.

- B/W Copies: \$.008 per image (8/10ths of a cent)
- Color Copies: \$.059 per image (5.9 cents)

Quote valid for 10 days. Set-up of print/scan feature may require additional hardware and/or cables and is dependent upon an evaluation of customer's existing configuration. Customer is responsible for the cost of any necessary hardware and/or cables.

Purchase Pricing PROPOSAL



Presented to Jasper County Jail

By Premier - Nick Grossman

On 1/17/2023

NASPO

Negotiated Contract : 072808000

Solution			
Item	Product Description	Agreement Information	Requested Install Date
1.	C8135H2 (XEROX C8135H2)	Purchase Price: \$4,104.00 Customer Ed: \$312.00 Analyst Services: \$160.00	12/23/2022
2.	C8135T2 (XEROX C8135T2)	Purchase Price: \$3,994.00 Customer Ed: \$312.00 Analyst Services: \$160.00	12/23/2022
Total Purchase Amount		\$9,042.00 (Excluding Applicable Taxes)	

Maintenance Pricing					
Item	Monthly Minimum Payment	Meter	Print Charges		Maintenance Plan Features
			Volume Band	Per Print Rate	
1. C8135H2	\$0.00	1: Black and White Impressions	All Prints	\$0.0066	- Term: 36 Months - Consumable Supplies Included for all prints - Pricing Fixed for Term
		2: Color Impressions	All Prints	\$0.0450	

All information in this proposal is considered confidential and is for the sole use of Jasper County Jail. If you would like to acquire the solution described in this proposal, we would be happy to offer a Xerox order agreement. Pricing is subject to credit approval and is valid until 2/16/2023.

For any questions, please contact me at (641)752-1200

Maintenance Pricing (Cont'd)

Item	Monthly Minimum Payment	Print Charges			Maintenance Plan Features
		Meter	Volume Band	Per Print Rate	
2. C8135T2	\$0.00	1: Black and White Impressions	All Prints	\$0.0066	<ul style="list-style-type: none"> - Term: 36 Months - Consumable Supplies Included for all prints - Pricing Fixed for Term
		2: Color Impressions	All Prints	\$0.0446	
Total	\$0.00	Minimum Payments (Excluding Applicable Taxes)			



January 16, 2023

PROPOSAL FOR
JASPER COUNTY

Prepared by:

Paul Schut

Technology Advisor
515-473-7127
Paul.Schut@marconet.com



Managed Services



Copiers & Printers



Audio Visual



Business IT Services



JASPER COUNTY JAIL

RECOMMENDED PRINT SOLUTION – OPTION B

QTY	ITEM	DESCRIPTION
1	AA2J011X001	KONICA C360i COLOR MFP

Specifications

- 36 Monochrome Pages Per Minute
- 36 Color Pages Per Minute
- Copy/Print/Scan
- 150 Sheet Bypass Tray
- (2) 500 Sheet Paper Trays
- (1) 1,500 Sheet Large Capacity Tray
- (1) 1,000 Sheet Large Capacity Tray
- 100 Sheet Single Pass Document Feeder
- Wireless Connectivity
- Mobile Printing

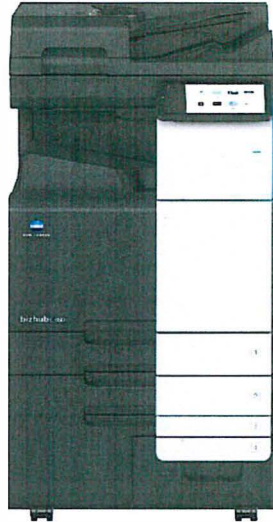

PURCHASE PLAN

- Purchase Price**\$3,815.09**

ADDITIONAL SERVICES

Delivery, Installation, Initial Supplies & Initial Training.....Included
 Removal and Recycling of existing equipment included

SERVICE AGREEMENT

The service and supply contract includes all parts, labor, mileage, drums, toner, and developer (except paper).

SERVICE & SUPPLIES.....\$134.46/month

- Black and White Prints included per Month: 4,201
- Black and White Print Overage: \$0.009/Print
- Color Prints **included** per Month: 1,556
- Color Print Overages: \$0.0589/Print

*The above pricing does not include applicable sales tax.
 Above prices are valid through January 31, 2023*

Accepted by: _____ Date: _____

By signing this proposal, you are authorizing Marco Technologies LLC to order, install and invoice the above listed equipment.

FACT SHEET ON GPS MONUMENT USE IN JASPER COUNTY



Background/History

1. GPS Monument network (also known as control monuments) was installed in 2005. Replaced a less comprehensive network of USGS control monuments within Jasper County utilized for horizontal and vertical control.
2. Control monuments were installed on a 3-mile grid and allowed the GPS (base & rover w/ 5-mile range at that time) to use 4 monuments around any local project and apply a combined scale factor to achieve very tight control both, vertical and horizontal.
3. Control monuments were critical when using GPS for surveying to establish tight vertical tolerance for projects such as bridges, PCC pavement, grade staking, etc.
4. GPS Monument network enabled 1 person to do the same work previously done by a 3-to-4-person crew.
5. Control network was utilized for control/scale each time the county is flown for new aerial images.
6. Control monuments were used by:
 - a. Secondary Roads
 - b. Private Surveyors
 - c. Iowa DOT

Current Situation

1. County secondary roads GPS survey equipment connects to Iowa Real-Time Network (IATRN). GPS unit can on its own gain tight control for project surveying. Under normal circumstances control monuments are used as a check or to resolve anomalies with the data.
2. County secondary roads total Station (robotic) surveying equipment used when satellite coverage is inadequate (cloud cover, maintenance activities, etc.) or when line of sight cannot be established (tree cover, terrain, etc.) or both.
3. Control monuments are used to establish control with total station, or a combination of points established by the GPS unit (from point(s) where control can be achieved) and the control monuments.
4. Private surveyors rarely use control monuments. Iowa DOT may still use monuments.
5. NAD83, the horizontal datum is off center by 2.2 meters. NAVD 88, the vertical datum is off from current geoid models. Hence the 0.75-meter vertical anomaly.

6. Iowa converting to International Foot. Iowa code amended January 1st to adopt federal definition of a foot. First step to new datum.
7. Iowa code ties Iowa plane coordinate system to the United States National Geodetic Survey (NGS). Chapter 355.16.

Future Risk/Opportunities

1. NAD83 gets replaced by NATRF 2022 and control monuments will become obsolete. Loss of accuracy and additional field and office time expended in using coordinate transformation tools.
2. Control network could be updated and grid spacing increased to 6-mile grid without loss in accuracy or need for new survey equipment. Potential 30% costs savings on updating. Requested revised proposal.

**Proposal to Update the
2005 Jasper County Geodetic Control Network
01-12-2023**

A. PURPOSE

The purpose of this estimate is to provide all the labor and materials required to update and modernize the existing 2005 Jasper County geodetic control network. The network update will support the future National Spatial Reference System (NSRS) modernization including the modernized Iowa State Plane Coordinate System.

B. INTRODUCTION

The original Jasper County geodetic control monuments were installed in 2005. A county-wide GPS network provided state plane coordinates tied to the existing NGS horizontal and vertical datums. NGS is currently in the process of replacing the existing datums. The modernized 2022 datums will have significant coordinate shifts in the magnitude of 2.2 meters horizontally and 0.75 meters vertically. To prepare for the modernized 2022 horizontal and vertical datums, NGS recommends new GPS field observations and subsequent countywide network adjustment.

New "static" GPS field observations will be required to readjust the Jasper County network to the current NAD83(2011) datum. The new GPS field observations will guarantee the correct positional accuracy of the existing network monuments. The new GPS field observations will also support the future 2022 datums and the computation of the new Iowa State Plane Coordinates based upon the geodetic control defined in the NSRS modernization.

C. SCOPE OF SERVICES

Dan Corbin, Inc. (DCI) will provide all the labor and equipment required to perform a complete post-processed "static" GPS survey. New GPS field observations will be collected for the entire network of permanent Jasper County GPS monuments.

A new countywide least squares network adjustment will be completed. All processed data and error factors will be computed using a 95% confidence factor. The minimum and maximum ratios of the fully constrained adjustment shall be included in the report. The new network will be directly tied horizontally to the latest NAD83(2011) datum and vertically to the latest NAVD88 datum.

A network adjustment summary including the final adjustment statistics, network vector map, AutoCAD drawing with point locations, and a xyz coordinate listing with complete point attributes will be provided in hard copy and digital form. Coordinates will be provided in the Iowa State Plane South Zone (1402) and in the IaRCS Zone 9 projection.

The GPS field observations and network adjustment will be performed under the direct supervision of Gary G. Brown P.L.S. a duly licensed Land Surveyor in the State of Iowa.

A complete set of the raw GPS observations including the final post-processed network vectors will be archived and saved for future use by the County. Utilizing the archived observations will greatly reduce the cost of future network re-adjustments.

D. PRE-SURVEY MONUMENT RECONNAISSANCE (Spring of 2023)

Prior to the new GPS field observations all the Jasper Co. network monuments will be field located.

- Monuments will be uncovered and/or dug out.
- Brush and weeds will be cut back.
- Monuments will be left in a “tripod ready” condition.
- A numbered and flagged lathe will be set at each site.
- A close-up picture of the monument and a site picture will be captured at each site.
- An Excel listing of the current field conditions and digital copies of the pictures will be submitted to the County Engineer for review.

Reconnaissance Cost **\$8,250**

E. REPLACE DESTROYED MONUMENTS (per Co. Engineer's approval)

Install new Berntsen driven rod monuments complete with new survey caps encased in PVC pipes with aluminum access covers. Cost = \$947 per mobilization + \$1021 per monument (As an example, the cost to replace 2 monuments is: $\$947 + (2 \times \$1021) = \$2,989$)

F. NA2011 NETWORK ADJUSTMENT (110 network monuments) (Summer of 2023)

New static GPS field observations and least squares network adjustment including the PLS Certification by Gary G. Brown for the re-measure and network adjustment. Post-processed GNSS vectors to select Continuously Operating Reference Stations (CORS) and/or laRTN stations will be included in the network.

Cost **\$38,776**

G. NA2011 MONUMENT RECORDS (Winter of 2023/24)

Republish the Monument Records from the 2005 Jasper Co. GPS Report with the new NA2011 point coordinate data and attributes including the laRCS Zone 9 coordinates. Republish with the existing field ties. Provide one hard copy and one digital copy.

Cost **\$4,217**

H. MODERNIZED NATRF 2022 “Level 1” NETWORK ADJUSTMENT (2025 per NGS)

Using the archived static network vectors from this contract, release the network from the obsolete geodetic control, lock the network to the new 2022 geodetic control and re-adjust the Jasper County control network to the North American Terrestrial Reference Frame (NATRF) of 2022. Republish the Monument Records from the Jasper Co. GPS Report with the new modernized 2022 coordinate data and attributes including the new modernized Zone 9 Iowa State Plane Coordinates. Republish with the existing field ties. Provide one hard copy and one digital copy.

Cost **\$7,017**

I. TERMS AND CONDITIONS

The services performed for this project will be invoiced as the work is completed. The costs provided in this contract are good faith estimates. DCI will not exceed these costs without previous consent from the Client. In the event the scope of service does change and require additional work; all additional work will be invoiced at an hourly rate of \$175/hr.

Payment terms are as follows: Net 30 days – 1.5% per month on all accounts over 30 days unless otherwise specified by the Client at the time of contract.

The costs in this Proposal are valid for 90 days from the date hereof and become binding if signed and delivered by both parties during that period.

J. LIMITATION OF DAMAGES

In the event of the breach of this Agreement by either party, it's agents or employees, or any claim of damages by one party against the other, based on any legal or equitable claim, the parties agree that the amount of damages that may be recovered by any party shall be limited to a sum no greater than the total amount of the payments to be made pursuant to this Agreement.

K. SAVING CLAUSE

Should any provisions of this contract be deemed unenforceable by a court of law, all the other provisions shall remain in effect.

Dan Corbin, Inc.
28 River Ridge Lane
Cedar Falls, IA 50613
Email: dcorbin@cfu.net

Jasper County

By: Dan Corbin
Dan Corbin, President

By: _____
Jasper County

Date 1-12-2023

Date _____

Attest:

Jenna Jennings, Auditor

100053
IAAM Ames CORS

100052
IAAM Marshalltown

100069
IA TA Tama CORS

100051
IAOM Des Moines (3)

Jasper Co, IA 2023 Geodetic Control Network

Prepared by:
Dan Corbin, Inc.
01-12-2023

100050
IASS Des Moines

100070
IAAM Malcom

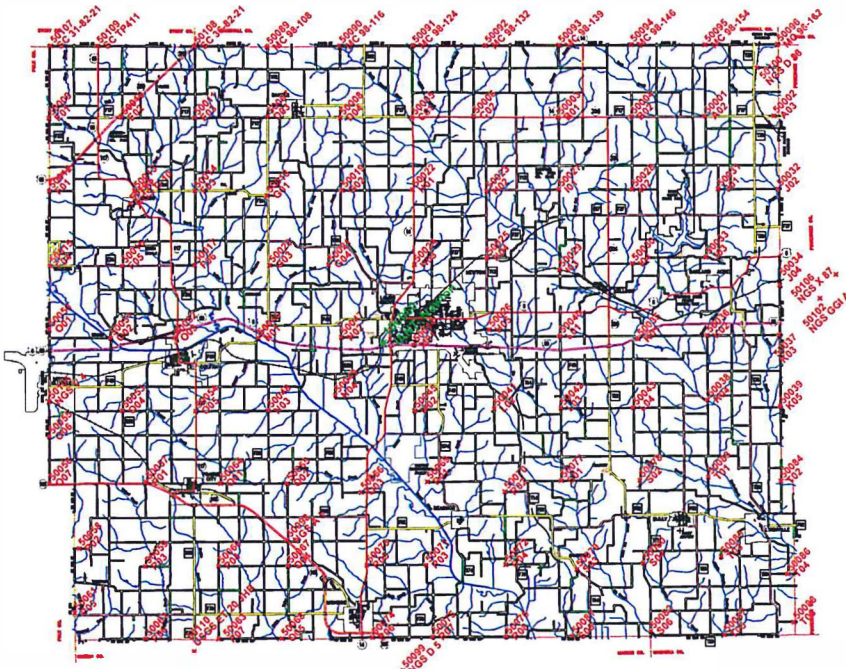

5007
OPEX

5008
REG L BT

100049
IAAD Maquoketa CORS

100059
IAAM Knoxville

100068
IAOK Okaloosa CORS



Contracts and Specifications Bureau

01/20/2023 10:32:08 AM

Project(s) and Vendor Ranking

Page 1 of 2

Call Order: 012

Letting Date: January 18, 2023 10:00 A.M.

Letting Status: AWARDED

Contract Period: Start Date: 05/01/23 125 Working Days

Contract ID: 50-C050-116

Awarded Vendor: HERBERGER CONSTR. CO., INC.

Primary County: JASPER

DBE Goal: 3.0%

Project Information:

Project: BRS-C050(116)-60-50

County: JASPER

Route: F48

Location: On County Road F48, Over Squaw Creek, on the west side of W 116th St S S11 T79 R21

WorkType: RECONSTRUCTION - BRIDGE DECK REPLACEMENT

Prj Awd Amt: \$1,076,454.89



Contracts and Specifications Bureau

Tabulation of Construction and Material Bids

Call Order: 012

Contract ID: 50-C050-116

Primary County: JASPER

Letting Date: January 18, 2023

Line No / Item Number				(1) HERBERGER CONSTRUCTION CO., INC.					
Item Description				Unit Price	Ext Amount	Unit Price	Ext Amount	Unit Price	Ext Amount
Alt Set / Alt Member	Quantity and Units	Unit Price	Ext Amount	Unit Price	Ext Amount	Unit Price	Ext Amount	Unit Price	Ext Amount
SECTION: 0001	REPAIR ITEMS FOR A 120'-0 X 30'-0 CONTINUOUS CONCRETE SLAB BRIDGE					Cat Alt Set:		Cat Alt Member:	
0010	2101-0850001 CLEARING AND GRUBBING	0.100	ACRE	16,100.00000	1,610.00				
0020	2102-2710070 EXCAVATION, CLASS 10, ROADWAY AND BORROW	2,724.000	CY	5.35000	14,573.40				
0030	2102-2710090 EXCAVATION, CLASS 10, WASTE	3,224.000	CY	8.60000	27,726.40				
0040	2104-2710020 EXCAVATION, CLASS 10, CHANNEL	2,350.000	CY	5.35000	12,572.50				
0050	2105-8425015 TOPSOIL, STRIP, SALVAGE AND SPREAD	1,700.000	CY	6.40000	10,880.00				
0060	2121-7425020 GRANULAR SHOULDERS, TYPE B	70.000	TON	42.80000	2,996.00				
0070	2123-7450020 SHOULDER FINISHING, EARTH	2.200	STA	1,280.00000	2,816.00				



Tabulation of Construction and Material Bids

Call Order: 012

Contract ID: 50-C050-116

Primary County: JASPER

Letting Date: January 18, 2023

Line No / Item Number				(1) HERBERGER CONSTRUCTION CO., INC.					
Item Description				Unit Price	Ext Amount	Unit Price	Ext Amount	Unit Price	Ext Amount
Alt Set / Alt Member	Quantity and Units	Unit Price	Ext Amount	Unit Price	Ext Amount	Unit Price	Ext Amount	Unit Price	Ext Amount
SECTION: 0001 REPAIR ITEMS FOR A 120'-0 X 30'-0 CONTINUOUS CONCRETE SLAB BRIDGE						Cat Alt Set:		Cat Alt Member:	
0150	2414-6424124	262.400	LF	110.00000	28,864.00				
	CONCRETE OPEN RAILING, TL-4								
0160	2417-0225030	1.000	EACH	1,050.00000	1,050.00				
	APRONS, METAL, 30 IN. DIA.								
0170	2417-1060024	48.000	LF	52.00000	2,496.00				
	CULVERT, CORRUGATED METAL ROADWAY PIPE, 24 IN. DIA.								
0180	2417-1060030	102.000	LF	77.00000	7,854.00				
	CULVERT, CORRUGATED METAL ROADWAY PIPE, 30 IN. DIA.								
0190	2501-0201042	840.000	LF	68.00000	57,120.00				
	PILES, STEEL, HP 10 X 42								
0200	2501-0201489	750.000	LF	110.00000	82,500.00				
	PILES, STEEL, HP 14 X 89								
0210	2501-5478089	177.600	LF	210.00000	37,296.00				
	CONCRETE ENCASEMENT OF STEEL H PILES, HP 14 X 89 (P10L TYPE 3)								



Contracts and Specifications Bureau

Tabulation of Construction and Material Bids

Call Order: 012

Contract ID: 50-C050-116

Primary County: JASPER

Letting Date: January 18, 2023

Line No / Item Number				(1) HERBERGER CONSTRUCTION CO., INC.					
Item Description				Unit Price	Ext Amount	Unit Price	Ext Amount	Unit Price	Ext Amount
Alt Set / Alt Member	Quantity and Units								
SECTION: 0001 REPAIR ITEMS FOR A 120'-0 X 30'-0 CONTINUOUS CONCRETE SLAB BRIDGE						Cat Alt Set:		Cat Alt Member:	
0430	2602-0000020	1,145.000	LF	2.00000	2,290.00				
SILT FENCE									
0440	2602-0000030	156.000	LF	2.00000	312.00				
SILT FENCE FOR DITCH CHECKS									
0450	2602-0000101	1,301.000	LF	0.05000	65.05				
MAINTENANCE OF SILT FENCE OR SILT FENCE FOR DITCH CHECK									
0460	2602-0000312	400.000	LF	4.50000	1,800.00				
PERIMETER AND SLOPE SEDIMENT CONTROL DEVICE, 12 IN. DIA.									
0470	2602-0010010	1.000	EACH	500.00000	500.00				
MOBILIZATIONS, EROSION CONTROL									
0480	2602-0010020	1.000	EACH	1,000.00000	1,000.00				
MOBILIZATIONS, EMERGENCY EROSION CONTROL									
Section Totals:					\$1,076,454.89				
Contract Item Totals					\$1,076,454.89				



Tabulation of Construction and Material Bids

Call Order: 012

Contract ID: 50-C050-116

Primary County: JASPER

Letting Date: January 18, 2023

Contract Time Totals

Contract Grand Totals

\$1,076,454.89

() indicates item is bid as Lump Sum

Tuesday, January 17, 2023, the Jasper County Board of Supervisors met in regular session at 9:30 a.m. with Supervisors Stevenson, Talsma, and Cupples present and accounted for; Chairman Talsma presiding.

Motion by Cupples, seconded by Stevenson to amend the agenda to include a Hiring Resolution for Elderly Nutrition.

YEA: STEVENSON, TALSMA, CUPPLES

Motion by Stevenson, seconded by Cupples to adopt Resolution 23-03 Determining the Necessity and Setting Dates of a Consultation on January 23, 2023 in the large conference room at the Administration Building at 1:30 P.M. and a Public Hearing on a Proposed Urban Renewal Plan on February 7, 2023 in the Board of Supervisors room at 9:30 A.M. for a Proposed Urban Renewal Area in Jasper County, State of Iowa.

YEA: STEVENSON, TALSMA, CUPPLES

A complete copy of the Resolution is on file in the Office of the Jasper County Auditor.

Motion by Cupples, seconded by Stevenson to adopt Resolution 23-04 Authorizing the Establishment of an Iowa Reinvestment District for the Newton Legacy District.

YEA: STEVENSON, TALSMA, CUPPLES

A complete copy of the Resolution is on file in the Office of the Jasper County Auditor.

Motion by Stevenson, seconded by Cupples to approve Section E – Certification and Release of Information.

YEA: STEVENSON, TALSMA, CUPPLES

Building and Grounds Director, Adam Sparks, asked for direction on a policy for the County parking lot by the elections building. The Board suggested drafting language for a new sign showing times and sending it to the County Attorney for approval. The Board will re-address the issue once the County Attorney approves the language for the sign.

IT Director, Ryan Eaton, requested the transition of GIS Coordination and budgeting be moved under IT.

Motion by Cupples, seconded by Stevenson to move all responsibilities for GIS under the IT Department. GIS will remain a stand-alone department under Dept 55.

YEA: STEVENSON, TALSMA, CUPPLES

Motion by Cupples, seconded by Stevenson to adopt Resolution 23-05, a hiring resolution certifying the following appointment to the Auditor for payroll implementation:

<u>DEPARTMENT</u>	<u>POSITION</u>	<u>EMPLOYEE</u>	<u>PAY RATE</u>	<u>RANGE/STEP</u>	<u>EFFECTIVE DATE</u>
Maintenance	Custodian	Jennifer Bracy	\$16.63	Year 2 Union Scale	01/30/2023

YEA: STEVENSON, TALSMA, CUPPLES

A complete copy of the Resolution is on file in the Office of the Jasper County Auditor.

Motion by Cupples, seconded by Stevenson to adopt Resolution 23-06, a hiring resolution certifying the following appointment to the Auditor for payroll implementation:

<u>DEPARTMENT</u>	<u>POSITION</u>	<u>EMPLOYEE</u>	<u>PAY RATE</u>	<u>RANGE/STEP</u>	<u>EFFECTIVE DATE</u>
Elderly Nutrition	Delivery Driver	Malissa Wilson	\$10.34	Range 9/Hire- In Rate Hourly Non- Bargaining Rate	01/18/2023

YEA: STEVENSON, TALSMA, CUPPLES

A complete copy of the Resolution is on file in the Office of the Jasper County Auditor.

Motion by Stevenson, seconded by Cupples to approve Veteran Affairs Quarterly Reports for 1st and 2nd Quarter for the periods beginning July 1, 2022 and ending December 31, 2022.

YEA: STEVENSON, CUPPLES, TALSMA

VA Administrator, Alyssa Wilson, presented the need for a Part-Time position in the office. The Board decided further discussion would take place during budget hearings. No other action was taken.

Engineer, Mike Frietsch, presented a contract with Stahl Construction for CMAR for Secondary Roads Liberty Ave Yard Phase 1 Project. ARPA funds will be funding all of Phase 1 project. One change to the contract per the County Attorney was under Article 1 section 1.1.7, Other Project Information, extending the end date to make it longer should we need more time for the generator since they are so far out on delivery dates. The Construction Manager's Preconstruction Phase 1 will be \$15,000.00 payable in three, equal monthly installments of \$5,000.00 as preconstruction progresses. The Construction Managers fee will be 2.5% of the actual cost of construction.

Motion by Cupples, seconded by Stevenson to approve the contract with Stahl Construction for CMAR for Secondary Roads Liberty Ave Yard Phase 1 Project.

YEA: STEVENSON, CUPPLES, TALSMA

Engineer, Mike Frietsch, presented a proposal to update the 2005 Jasper County Geodetic Control Network. This would shift the 2022 datums in the magnitude of 2.2 meters horizontally and 0.75 meters vertically. Reconnaissance Cost for the Spring of 2023, FY23, would be \$8,250.00. A Network Adjustment cost for FY24 in the summer of 2023 would be \$38,776.00. Starting in the winter of 2023/2024, monument records would cost \$4,217.00. The final project would be complete in 2025, FY25, with modernized NATRF 2022 "Level 1" Network adjustments costing \$7,017.00.

Motion by Cupples, seconded by Stevenson to approve the proposed update of the 2005 Jasper County Geodetic Control Network pending Scott Nicholson and Ryan Eaton's review and approval.

YEA: STEVENSON, CUPPLES, TALSMA

Remaining ARPA Fund allocation was discussed and how we would proceed forward after the two major projects, ALS and Liberty Ave Yard Phase 1, were complete. \$2 million has been set aside for the ALS program, and \$3.4 million for Liberty Ave Yard Phase 1 only. Mike Frietsch stated that they would have a better idea on the projected cost for his project by the end of March or April. Lt. Shutts also spoke on behalf of the ALS program and mentioned they would have a better idea by the end of 2023 on how much of

the ARPA funds they would need. MercyOne was present and discussed they could not move forward with the ER renovation project until they had a better idea on the total funds they would be working with for their project.

Motion by Stevenson, seconded by Cupples to support the MercyOne ER Renovation project and allocate any unused ARPA funds to the project.

YEA: STEVENSON, CUPPLES, TALSMA

Motion by Cupples, seconded by Stevenson to approve claims paid through 1/17/2023.

YEA: STEVENSON, CUPPLES, TALSMA

Motion by Stevenson, seconded by Cupples to approve Board of Supervisors minutes for January 10, 2023.

YEA: STEVENSON, CUPPLES, TALSMA

Motion by Stevenson, seconded by Cupples to acknowledge the acceptance of the Fifth Judicial District Annual Report for FY2022.

YEA: STEVENSON, CUPPLES, TALSMA

No Board Appointments were made.

Motion by Stevenson, seconded by Cupples to adjourn the Tuesday, January 17, 2023 meeting of the Jasper County Board of Supervisors.

YEA: STEVENSON, CUPPLES, TALSMA

Directly following the Board of Supervisors meeting, Secondary Roads had a work session on GRAMS.

Jenna Jennings, Auditor

Brandon Talsma, Chairman